

# WIBE CLX<sup>3</sup> SYSTEM PRODUCT AND TECHNICAL PAGES

Revolutionary bolt-free support system.

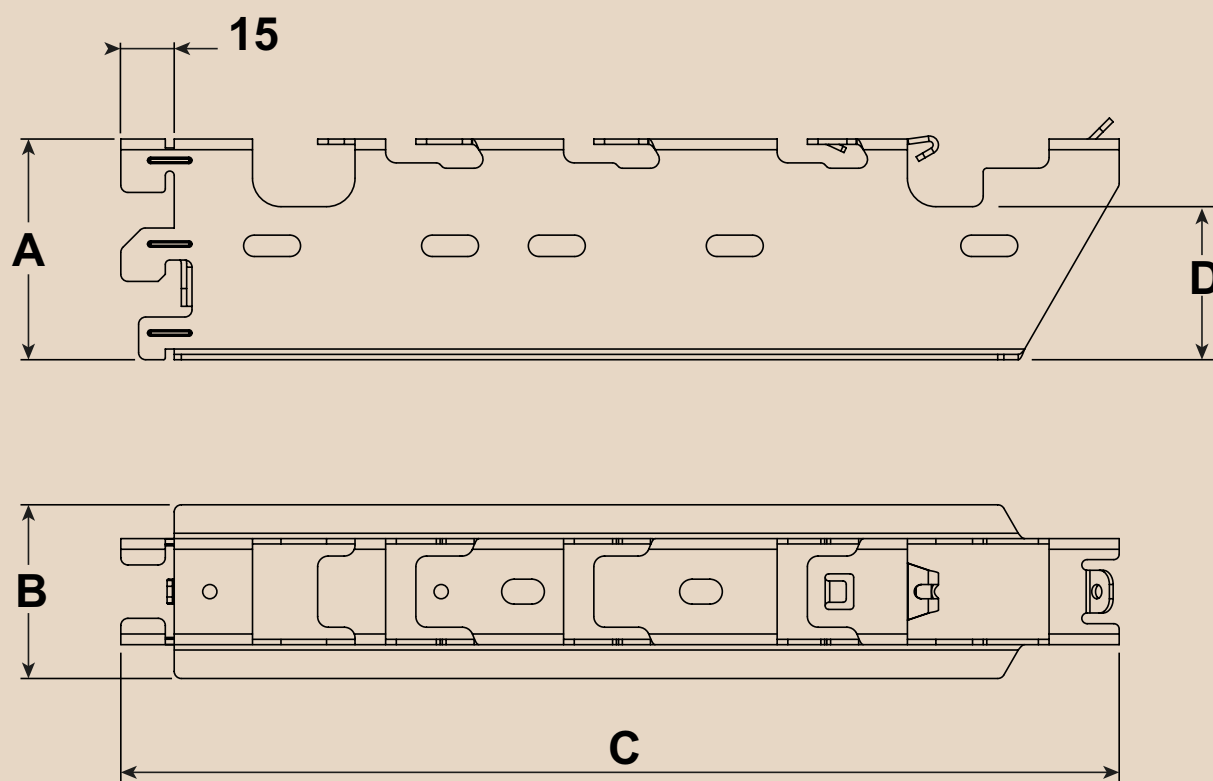

# CLX<sup>3</sup> support system

## Pre-galvanized - Corrosion class C2

### Vertical piece/Fixing rail

Type	Dimensions A/B/C mm	Weight kg/100 pcs	EAN code	Ref. No.
<b>CLX<sup>3</sup> pendant 24/48</b>				
Vertical piece/pendant to be used for ceiling suspended mounting. Perforated pattern to be used with CLX <sup>3</sup> cantilever arm or CLX <sup>3</sup> central suspension adapter. Open side can be used with T-bolt. Material: Steel, pre-galvanized.				
CLX <sup>3</sup> pendant-300	295/145/53	90.6	3606489904937	<b>CSU795632</b>
CLX <sup>3</sup> pendant-400	395/145/53	107.5	3606489904944	<b>CSU795633</b>
CLX <sup>3</sup> pendant-500	495/145/53	124.4	3606489904951	<b>CSU795634</b>
CLX <sup>3</sup> pendant-700	695/145/53	158.1	3606489904968	<b>CSU795635</b>
CLX <sup>3</sup> pendant-1000	995/145/53	208.7	3606489904975	<b>CSU795636</b>
CLX <sup>3</sup> pendant-1500	1495/145/53	294.2	3606481828323	<b>CSU795638</b>
<b>CLX<sup>3</sup> pendant rail 24/48</b>				
Pendant rail to be used for direct wall mounting or for vertical piece/pendants extentions. To be connected to the vertical piece/pendant together with the pendant joint CSU795325. Perforated pattern to be used with CLX <sup>3</sup> cantilever arm. Open side can be used with T-bolt. Material: Steel, pre-galvanized.				
CLX <sup>3</sup> rail 24/48 300	280/48/26	47.2	3606481828330	<b>CSU795640</b>
CLX <sup>3</sup> rail 24/48 1000	980/48/26	165.1	3606481828347	<b>CSU795641</b>
CLX <sup>3</sup> rail 24/48 3000	2980/48/26	502	3606489904982	<b>CSU795637</b>

### Adjustable ceiling plate

Type	Dimensions A/B/C mm	Weight kg/100 pcs	EAN code	Ref. No.
<b>CLX<sup>3</sup> adjustable ceiling plate</b>				
Adjustable ceiling plate. To be used for angular adjustment of pendant vs ceiling. Adjustment between 0-25°. Adjustable ceiling plate is to be mounted to the CLX <sup>3</sup> pendant. To be assembled with 4 screw set 22S (713694), need to be ordered separately. Tightening force of the screw set minimum torque 20 N.m. Material: Steel, pre-galvanized.				
CLX <sup>3</sup> adjustable ceiling plate	150/100/59	49.8	3606489904999	<b>CSU795639</b>

### Cantilever arms

Type	Dimensions A/B/C mm	Weight kg/100 pcs	EAN code	Ref. No.
<b>CLX<sup>3</sup> Cantilever arm</b>				
Cantilever arm to be used for mounting on vertical pieces or pendant/fixing rails. The cantilever arm is designed for fast click fixation of ladder type KHZSP, Defem mesh tray height 60/110 and Stago tray KG281/KB184/KB284 height 60. Stago trays need to be fastened with the fast fixing clamp (CSU08490100). Material: Steel, pre-galvanized.				
CLX <sup>3</sup> cantilever arm 100	62/170/49	28.3	3606489905002	<b>CSU795645</b>
CLX <sup>3</sup> cantilever arm 150	62/220/49	36.1	3606489905019	<b>CSU795646</b>
CLX <sup>3</sup> cantilever arm 200	62/280/49	42.8	3606489905026	<b>CSU795647</b>
CLX <sup>3</sup> cantilever arm 300	62/380/49	60.5	3606489905033	<b>CSU795648</b>
CLX <sup>3</sup> cantilever arm 400	92/480/49	90.9	3606489905040	<b>CSU795649</b>
CLX <sup>3</sup> cantilever arm 500	92/580/49	106.6	3606489905057	<b>CSU795650</b>
CLX <sup>3</sup> cantilever arm 600	92/680/49	119.7	3606489905064	<b>CSU795651</b>

### Fast fixing clamp

Type	Dimensions A/B/C mm	Weight kg/100 pcs	EAN code	Ref. No.
<b>Fast fixing clamp 60 SS</b>				
Fast fixing clamp to be used for fastening the Stago tray KG281/KB184/KB284 height 60 to the CLX <sup>3</sup> Cantilever arm. Fast fixing clamps are packed 25 pieces in a bag. Material: Stainless steel.				
Fast fixing clamp 60 SS	90/63/5	0.2	8712186028939	<b>CSU08490100</b>

## CLX<sup>3</sup> support system

Pre-galvanized - Corrosion class C2

### Central suspensions

Type	Dimensions A/B/C mm	Weight kg/100 pcs	EAN code	Ref. No.
<b>CLX<sup>3</sup> central suspension bracket, cable tray H40</b>				
Central suspension bracket used for mounting Wibe cable W1/W3/W70 trays height 40 on vertical pieces. Material: Steel, pre-galvanized.				
70	152/37/66	16.5	3606489905088	<b>CSU795653</b>
100	152/37/96	18	3606489905095	<b>CSU795654</b>
200 *	36/76/196	26.8	3606489905156	<b>CSU795660</b>
300 *	36/76/296	46	3606489905163	<b>CSU795661</b>
400 *	36/76/396	65.3	3606489905170	<b>CSU795662</b>
500 *	36/76/496	84.6	3606489905187	<b>CSU795663</b>
600 *	36/76/596	103.9	3606489905194	<b>CSU795664</b>
(*) the central suspension bracket shall first be assembled together with the CLX <sup>3</sup> central suspension adapter (CSU795700) to be able to click in the perforation pattern on the vertical piece.				
<b>CLX<sup>3</sup> central suspension bracket, ladder KHZSP</b>				
Central suspension bracket be used for mounting Wibe cable ladders type KHZSP on vertical pieces. The central suspension bracket shall first be assembled together with the CLX <sup>3</sup> central suspension adapter (CSU795700) to be able to click in the perforation pattern on the vertical piece. Material: Steel, pre-galvanized.				
200	37/78/185	33.4	3606489905101	<b>CSU795655</b>
300	37/78/285	53.1	3606489905118	<b>CSU795656</b>
400	37/78/385	72	3606489905125	<b>CSU795657</b>
500	37/78/485	90.1	3606489905132	<b>CSU795658</b>
600	37/78/585	109	3606489905149	<b>CSU795659</b>
<b>CLX<sup>3</sup> central suspension bracket, mesh tray Defem</b>				
Central suspension bracket be used for mounting Defem mesh trays on vertical pieces. Material: Steel, pre-galvanized.				
120-220	163/31/84	19.5	3606489905200	<b>CSU795665</b>
320 *	25/206/50	31.3	3606489905217	<b>CSU795666</b>
522-622 *	25/497/50	62.7	3606489905224	<b>CSU795667</b>
422 *	25/397/50	78.2	3606489905231	<b>CSU795668</b>
(*) the central suspension bracket shall first be assembled together with the CLX <sup>3</sup> central suspension adapter (CSU795700) to be able to click in the perforation pattern on the vertical piece.				
<b>CLX<sup>3</sup> central suspension adapter</b>				
Central suspension adapter to be first clicked to a CLX <sup>3</sup> central suspension bracket of choice. The adaptor fits to all types of CLX <sup>3</sup> central suspension brackets; ladder, tray and mesh. In a second step the adaptor with the central suspension bracket mounted is clicked in the perforation pattern in the rail or the pendant. Material: Steel, pre-galvanized.				
CLX <sup>3</sup> CSB adapter	166/31/39	17.7	3606489905248	<b>CSU795700</b>

### Wall bracket



#### Wall bracket for CLX<sup>3</sup> cantilevers.

To be used for direct fixation to wall. Single bolt fixation in keyhole, alternatively multi-bolt fixation in lateral holes for softer walls. Bolts are not included.  
Material: Steel, pre-galvanized.

Wall bracket for CLX <sup>3</sup> cantilevers	163/101/26	34	7321677958047	<b>CSU795804</b>
---	------------	----	---------------	------------------

# Technical information

## Use and installation

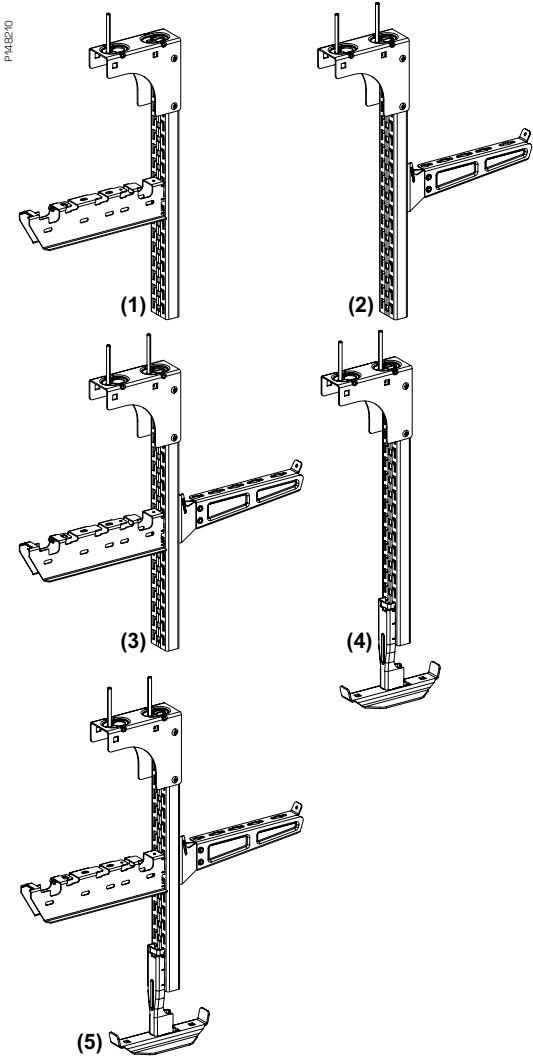

### CLX<sup>3</sup> General information

#### Standards

CLX<sup>3</sup> installation system is tested and following the classification according to the IEC 61537.



#### Usage of gloves

According to IEC 61537 it is always recommended to use protective gloves when handling and manipulating cable support systems.

#### Handling and storage

- Store in dry and covered places.
- Avoid moisture and pollutants.
- Do not remove the packing until installation.
- Take care when storing and handling so that the CLX<sup>3</sup> components are well protected from damage.

#### CLX<sup>3</sup> Pendant loading configurations

CLX<sup>3</sup> pendant is primarily designed for installation of the CLX<sup>3</sup> support system, but can also be used for T-bolt installation.

The system can be installed in different configurations:

- b Click direction (1): the cantilever and the ceiling plate are in the same direction
- b T-bolt direction (2): a cantilever is fixed with a T-bolt to the rail, in the opposite direction of the ceiling plate
- b T installation (3): combination of the first 2 installations
- b Central suspension (4): the pendant is completed by a central suspension bracket
- b T and central suspension (5).

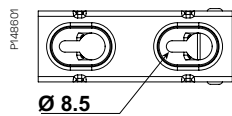

#### Fixation to the ceiling

##### Keyhole design

Keyhole design is facilitating easy mounting of the pendant to the ceiling by allowing the bolts to be pre-fixed before finally placing the pendant and tightening the bolts.

For concrete ceiling, use bolts type IMT38051.

For other bolts where bolthead is < 16 mm use washer u 16 mm.

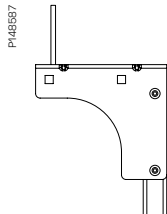

##### One bolt fixation

For click direction installation of CLX<sup>3</sup> Cantilever arm (1), use a single bolt, in the outer hole position on the ceiling plate.

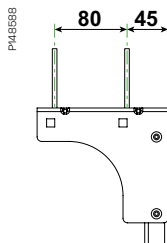

##### Two bolt fixation

For T-bolt suspension, central suspension, T installation and T and central suspension installation (2), (3), (4), (5), always fix the ceiling plate to the ceiling using 2 bolts.

Use the angle adaptor when the ceiling is not horizontal to level out the suspended pendant.

# Technical information

## Use and installation

### Pendant load calculation

To verify that the load applied to each pendant is within performance, it is necessary to calculate and consolidate the total tensile load force and the total moment-force on each pendant and for each cantilever and after that compare the calculated values with the defined loading limitations to ensure a safe installation.

### Total tensile force Ft calculation method

This is calculated as the sum of all forces applied to the pendant from the weight of cables on the length material.

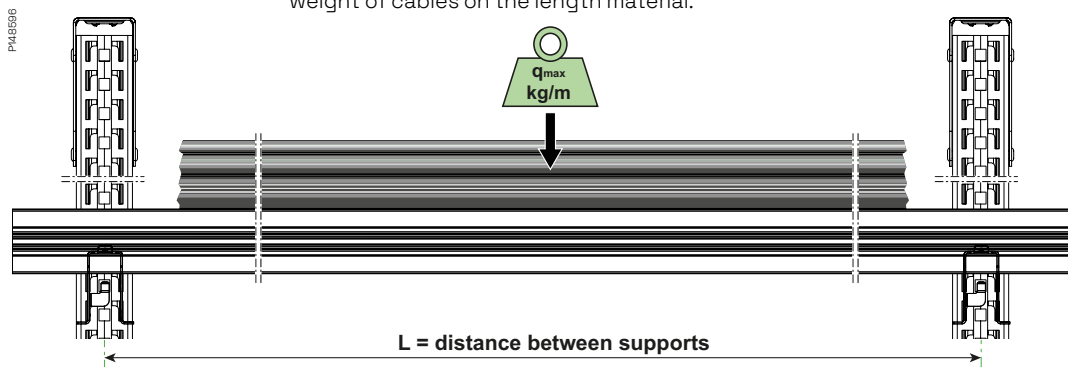

$$F_t \text{ (total load in N)} = L \text{ (span or supports distance in meters)} \times q_{max} \text{ (load in kg/m)} \times 10.$$

**In case of several layers are installed on the pendant then the sum of the Ft tensile load from all layers shall be calculated.**

### Total momentum force Mt calculation method

This is calculated as the sum of all the torsion forces applied to the pendant from the weight of cables on the length material and the offset distance created by the cantilever arm.

$$M_t \text{ (momentum in N.m)} = F_t \text{ (N)} \times d \text{ (distance between axis center and point load in meters)}$$

“d” depends of the position of the length material on the cantilever arm.

The distance **d** can be different depending on installation method. When the length material is installed on the full width of the cantilever, use **d1**. For length material that are installed at the outer end of the arm, use **d2**.

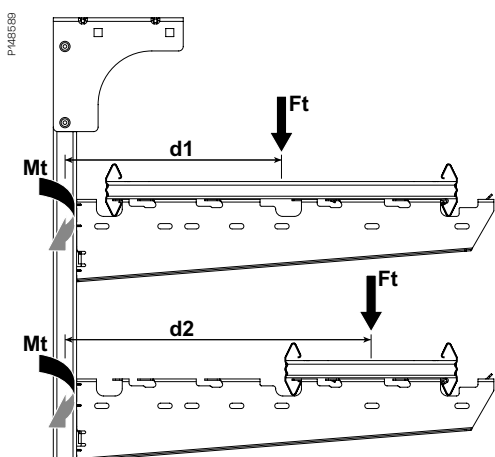

Model	PG	d1 (m)	d2 (m)
CLX <sup>3</sup> cantilever arm 100	CSU795645	0.09	Na
CLX <sup>3</sup> cantilever arm 150	CSU795646	0.110	
CLX <sup>3</sup> cantilever arm 200	CSU795647	0.140	
CLX <sup>3</sup> cantilever arm 300	CSU795648	0.190	0.340
CLX <sup>3</sup> cantilever arm 400	CSU795649	0.240	

**In case of several layers are installed on the pendant then the sum of the Mt momentum force from all layers shall be calculated.**



Ensure that the installation is designed so that  $\Sigma M_t$  and  $\Sigma F_t$  are under the limits.

# Technical information

## Use and installation

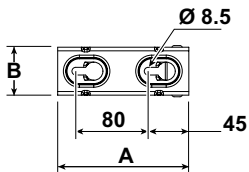
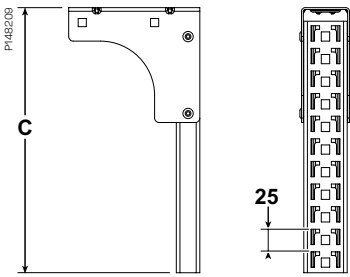
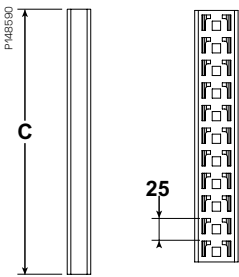
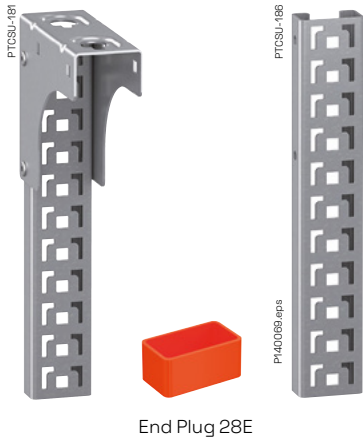

### CLX<sup>3</sup> Pendant 24/48

Vertical piece with a perforated pattern to be used for installation of CLX<sup>3</sup> cantilever arms or CLX<sup>3</sup> central suspension adapter. The open side of the rail can be used for installation of cantilever arms and brackets together with T-bolt. Can be joined to CLX<sup>3</sup> Rail 24/48 with pendant joint 2FJ.

Model	PG	High (mm) A	Width (mm) B	Length (mm) C
<b>CLX<sup>3</sup> pendant</b>				
CLX <sup>3</sup> pendant 24/48 300 mm PG	CSU795632	145	53	295
CLX <sup>3</sup> pendant 24/48 400 mm PG	CSU795633			395
CLX <sup>3</sup> pendant 24/48 500 mm PG	CSU795634			495
CLX <sup>3</sup> pendant 24/48 700 mm PG	CSU795635			695
CLX <sup>3</sup> pendant 24/48 1000 mm PG	CSU795636			995
CLX <sup>3</sup> pendant 24/48 1500 mm PG	CSU795638			1495
<b>CLX<sup>3</sup> rail</b>				
CLX <sup>3</sup> rail 24/48 300 mm PG	CSU795640	26	48	280
CLX <sup>3</sup> rail 24/48 1000 mm PG	CSU795641			980
CLX <sup>3</sup> rail 24/48 3000 mm PG	CSU795637			2980

### Pendants Safe Working Load (SWL)

SWL for bending moment of the pendant **Mt**.

Model	PG	Moment (N.m) Click side	Deflection (mm)
CLX <sup>3</sup> pendant 24/48 300 mm PG	CSU795632	235	2
CLX <sup>3</sup> pendant 24/48 400 mm PG	CSU795633		4
CLX <sup>3</sup> pendant 24/48 500 mm PG	CSU795634		7
CLX <sup>3</sup> pendant 24/48 700 mm PG	CSU795635		15
CLX <sup>3</sup> pendant 24/48 1000 mm PG	CSU795636		30
CLX <sup>3</sup> pendant 24/48 1500 mm PG	CSU795638		200

Tested according to IEC 61537 standard.

### SWL bending moment for Adjustable ceiling plate **Mt**.

Model	PG	Moment (N.m) Click side
CLX <sup>3</sup> adjustable ceiling plate	CSU795639	235

### SWL pendant tensile strength **Ft**.

Model	PG	Tensile load SWL (N) 1 bolt CLX <sup>3</sup>	Tensile load SWL (N) 2 bolts CLX <sup>3</sup>
CLX <sup>3</sup> pendant 24/48 300 mm PG	CSU795632	2000	5000
CLX <sup>3</sup> pendant 24/48 400 mm PG	CSU795633		
CLX <sup>3</sup> pendant 24/48 500 mm PG	CSU795634		
CLX <sup>3</sup> pendant 24/48 700 mm PG	CSU795635		
CLX <sup>3</sup> pendant 24/48 1000 mm PG	CSU795636		
CLX <sup>3</sup> pendant 24/48 1500 mm PG	CSU795638		

## Technical information

### Use and installation

#### Pendant limits, torque and deflection

In the diagram below it is possible to check if  $\Sigma Mt$  is below the momentum limitation of the pendant (end of line). It is also possible to see the deflection on the pendant at max  $\Sigma Mt$  and all values below.

#### Calculation example

For a cantilever size 600, full size ladder installation, 3 m span, load of 23 kg/m on a 1000 mm pendant.

1)  $\Sigma F$ : 3 m (span)  $\times$  23 kg/m (load)  $\times$  10 = 690 N will be the load for each pendant system.

2)  $\Sigma Mt$ : 690 (N)  $\times$  0.34 (m) = 234 N.m.

$\Sigma F$  = 690 N  $\leq$  2000 N and  $\Sigma Mt$  = 234 Nm  $\leq$  235 N.m.

3) Drawing of the lines on the graph: for 234 N.m, the deflexion on the pendant is **30 mm**.

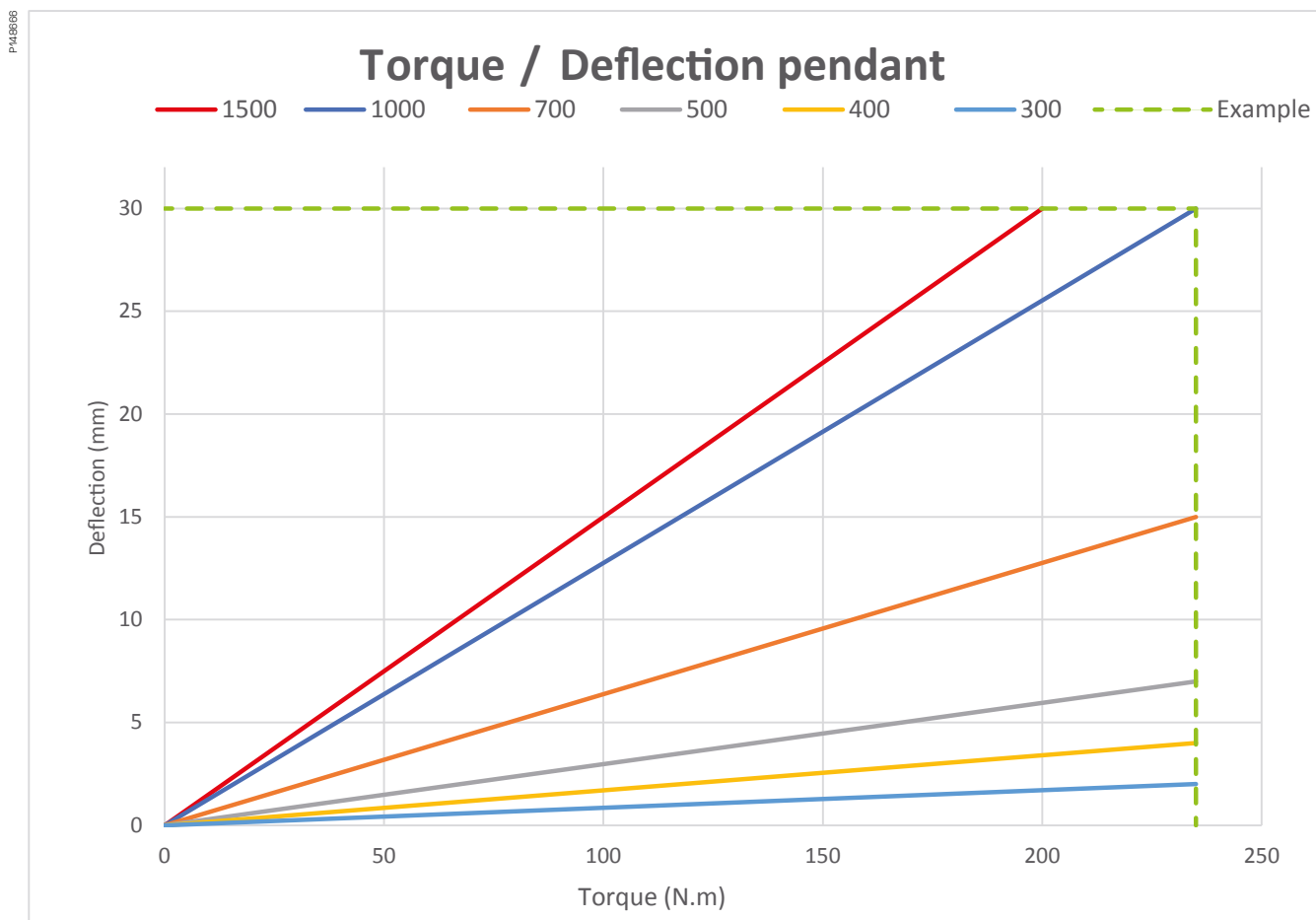

# Technical information

## Use and installation

### Distance between rails and offset

CLX<sup>3</sup> rail have a pitch between the patterns of 25 mm.

The support distance between the pendants should be at least than 1.5 m. If the length material can't be installed on the exact same level, the length material should be installed on the closest offset- pitch and never at more than 12.5 mm vertically from the previous pattern.

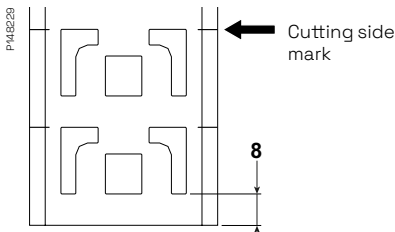
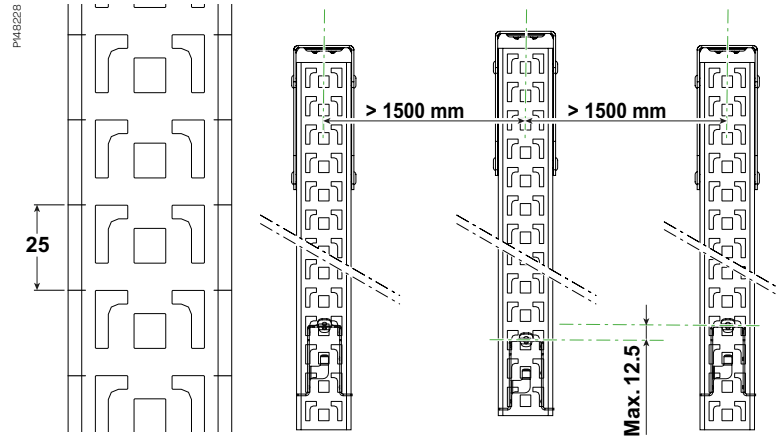

### Cutting of the pendant or rail

Cutting of the rail or the pendant should be made at 8 mm under the last pattern needed, as the side marks are showing. This to assure that there is enough material below the bottom pattern to secure proper fixation of the cantilever arm.

### Installation of the rail joint

CLX<sup>3</sup> rails can be joined together with pendant joint 2FJ.

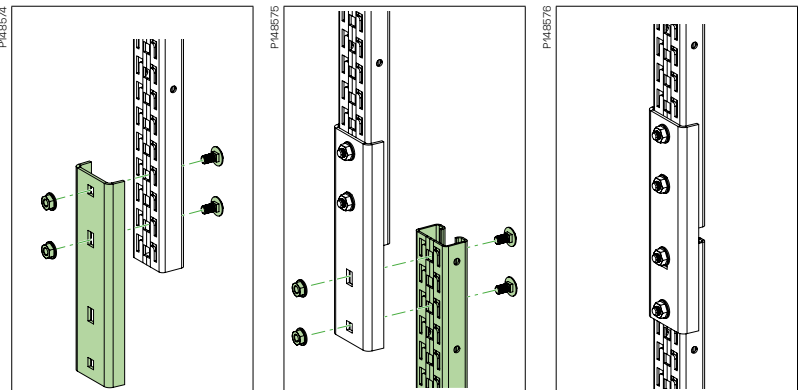

Place the joint on the rail in place, make sure the 2 top holes are in front of slots to install the included bolts and nuts.

Install the second rail as high as possible and install the other bolts and nuts.

Torque of the nuts **11 N.m.**

**Note:** extending the pendant with the rail joint will decrease the load capacity of the pendant. For SWL information when extending the pendants, contact Technical support.



# Technical information

## Use and installation



### CLX<sup>3</sup> Adjustable ceiling plate

Adjustable ceiling plate is used together with CLX<sup>3</sup> pendant to allow for angle correction up to 25°. The adjustable ceiling plate is fixed to the CLX<sup>3</sup> pendant with 4 screw set 22S to be ordered separately. The pendant can be fixed to the adjustable ceiling plate in both possible directions (1) and (2).

Model	PG	High (mm) A	Width (mm) B	Length (mm) C
CLX <sup>3</sup> adjustable ceiling plate PG	CSU795639	100	59	150

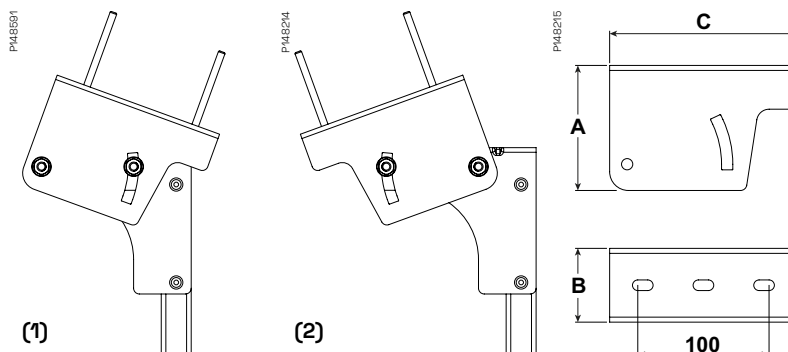

### Installation of the adjustable ceiling plate

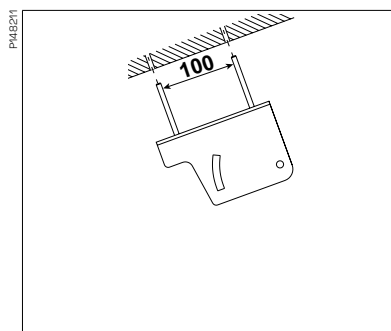

Fix the adjustable ceiling plate to the ceiling with 2 bolts.  
(c-c: 100 mm).

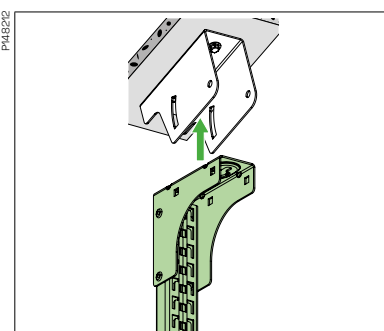

Insert the pendant into the adjustable ceiling plate.

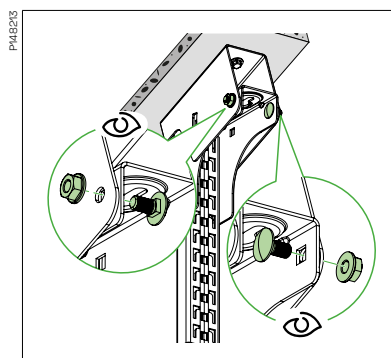

Fix the pendant to the adjustable ceiling plate with 4 bolt sets 22S and align the pendant to the vertical plane before tightening the bolts.

**Recommended torque 20 N.m.**

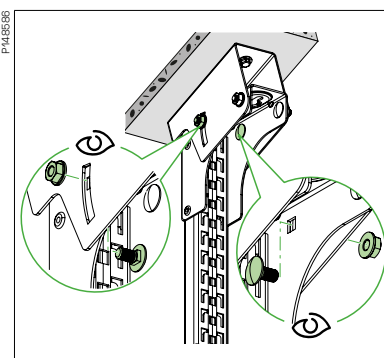

# Technical information

## Use and installation

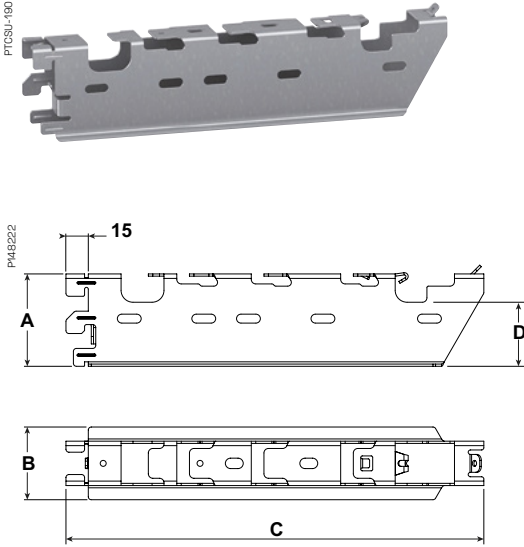

### CLX<sup>3</sup> Cantilever arm

The CLX<sup>3</sup> cantilever arm is a screw-less cantilever that clicks into the pattern in the CLX<sup>3</sup> pendant and rail. The cantilever arm is used to fix either the KHZSP ladder, the Defem mesh tray or the Stago height 60 trays. It can also be used for the Performa mesh trays together with fixation bolts.

Model	PG	High (mm) A	Width (mm) B	Length (mm) C	Height below ladder (mm) D
CLX <sup>3</sup> cantilever arm 100 PG	CSU795645	62	49	170	N/A
CLX <sup>3</sup> cantilever arm 150 PG	CSU795646	62	49	220	N/A
CLX <sup>3</sup> cantilever arm 200 PG	CSU795647	62	49	280	43
CLX <sup>3</sup> cantilever arm 300 PG	CSU795648	62	49	380	43
CLX <sup>3</sup> cantilever arm 400 PG	CSU795649	92	49	480	73
CLX <sup>3</sup> cantilever arm 500 PG	CSU795650	92	49	580	73
CLX <sup>3</sup> cantilever arm 600 PG	CSU795651	92	49	680	73

### Cantilever arm size compatibility

The click pattern on the cantilever arm is in some cases fitting more than one ladder width to make it possible to avoid pillars or obstacles on the wall. See the table and illustration below.

The table also clarifies which cantilever arm to use for each with of Defem mesh tray.

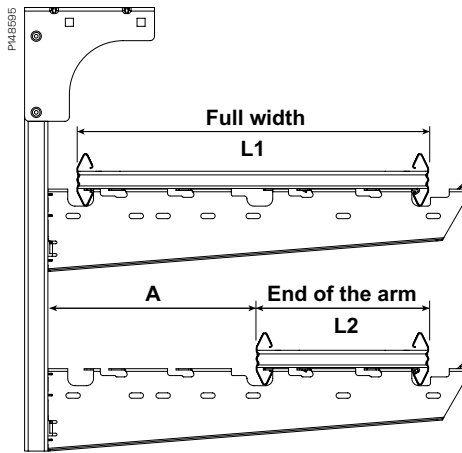

Model	PG	Compatible ladder		Space to the offset ladder (mm) A	Defem size compatibility
		L1	L2 (offset)		
CLX <sup>3</sup> cantilever arm 100 PG	CSU795645	NA	NA	NA	NA
CLX <sup>3</sup> cantilever arm 150 PG	CSU795646	NA	NA	NA	120
CLX <sup>3</sup> cantilever arm 200 PG	CSU795647	200	NA	NA	220
CLX <sup>3</sup> cantilever arm 300 PG	CSU795648	300	NA	NA	320
CLX <sup>3</sup> cantilever arm 400 PG	CSU795649	400	200	232	420
CLX <sup>3</sup> cantilever arm 500 PG	CSU795650	500	200	332	520
CLX <sup>3</sup> cantilever arm 600 PG	CSU795651	600	300	332	620

### Cantilever arms Safe Working Load (SWL)

SWL of the cantilever bracket

Model	PG	Safety working load as wall bracket (full width) (N)	Safety working load as wall bracket (end of the arm) (N)
CLX <sup>3</sup> cantilever arm 100 PG	CSU795645	1800	N/A
CLX <sup>3</sup> cantilever arm 150 PG	CSU795646	1800	
CLX <sup>3</sup> cantilever arm 200 PG	CSU795647	1800	
CLX <sup>3</sup> cantilever arm 300 PG	CSU795648	1250	
CLX <sup>3</sup> cantilever arm 400 PG	CSU795649	1250	1000
CLX <sup>3</sup> cantilever arm 500 PG	CSU795650	1250	750
CLX <sup>3</sup> cantilever arm 600 PG	CSU795651	1000	700

Tested according to IEC 61537 standard.

## Technical information

### Use and installation

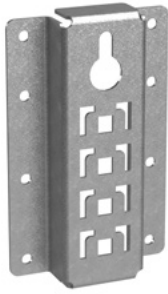

#### Installation of the Wall bracket

The Wall bracket is made to directly fix a Cantilever arm to a wall, without using a full-size rail. The Wall bracket doesn't reduce the SWL of the cantilever arm and the distance between the back of the cantilever and the wall is the same as with a rail.

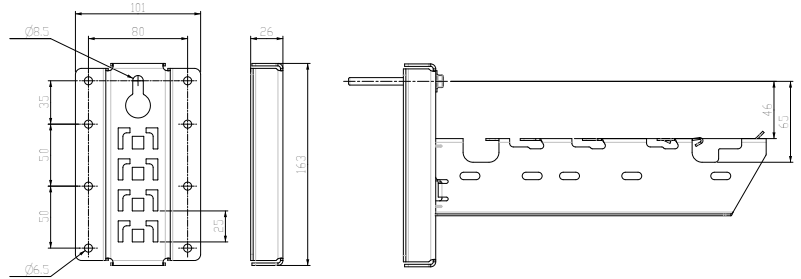

The wall bracket can be fixed in two different ways:  
With the keyhole (A) or with the lateral holes (B).

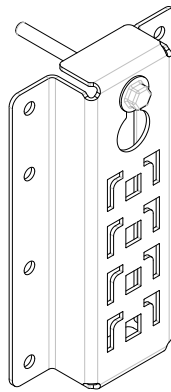

(A)

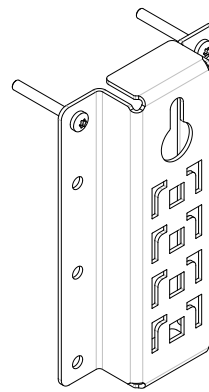

(B)

The keyhole design allows to pre-fix the bolt in the wall, before installing the bracket.

For concrete wall, use bolts IMT38051.

For non-concrete wall, M8 bolts with washer >Ø16 should be used.

For the lateral holes, the bracket should always be fixed with at least the two top Ø6mm holes (same height as the keyhole). The left and right bolts should be horizontally separated by 80mm (axis to axis).

# Technical information

## Use and installation

### Installation of cantilever arms

CLX<sup>3</sup> cantilever arms are clicked to the CLX<sup>3</sup> pendants and rails. Make sure to select a pattern allowing all hooks to grip and the full cantilever back to be supported by the rail. The horizontal wing must touch the rail.

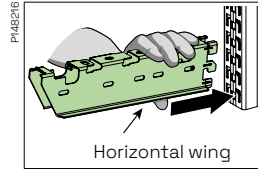

Hold the cantilever close to the hooks and insert the hooks in the rail.

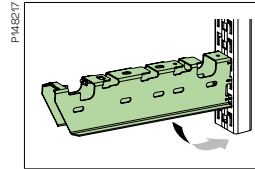

Press the cantilever until the horizontal/top surface touch the rail.

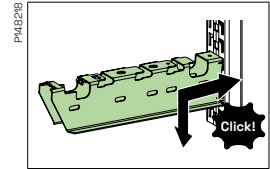

Press against the rail and pull it down until the locking lip go inside the slot in the rail.

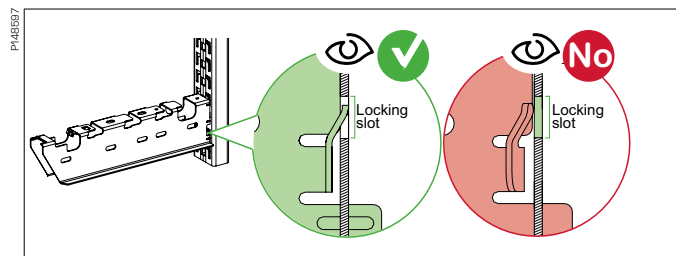

Visually check that the cantilever arm is properly positioned and the locking lip is positioned inside of the slot of the CLX<sup>3</sup> rail.



**Apply caution with unintended upward movements as it can cause the cantilever arm to unlock and therefore be released from the rail.**

### Uninstallation of CLX<sup>3</sup> cantilever arm using screwdriver

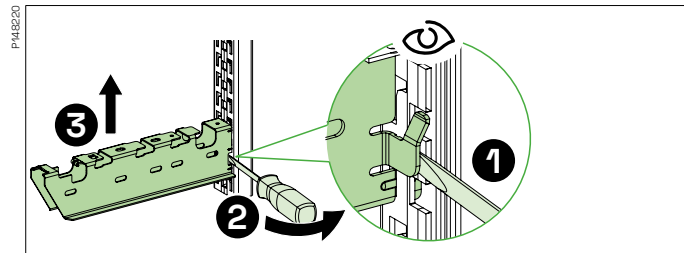

**1** Fit the head of the screwdriver between the rail and the locking lip of the cantilever. Use the screwdriver as a lever to **2** push the lip out of the rail. Deform the lip as little as possible and **3** push the cantilever up to be able to unhook the cantilever arm.

**Before reinstalling a cantilever that has been removed after installation, make sure the lip is locking properly. If not, correct the lip to the initial position.**

# Technical information

## Use and installation

### Installation of KHSZP ladders on cantilever arms

CLX<sup>3</sup> cantilever arms are designed to fix KHSZP ladders without need of tools or bolts.

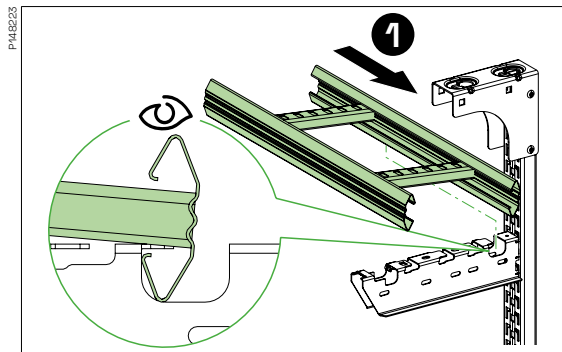

**1** Insert the ladder on the rail side. Pull it on the outside direction to lock this side in the lip.

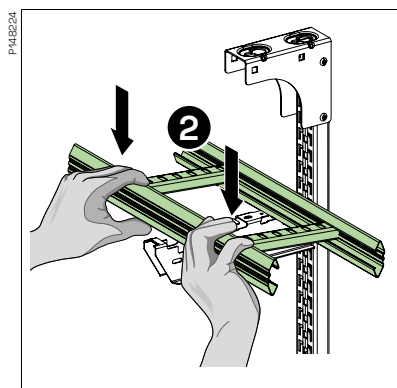

**2** Squeeze the free side of the ladder strongly down on the outer end of the cantilever until **●** the ladder overpasses the locking lip.

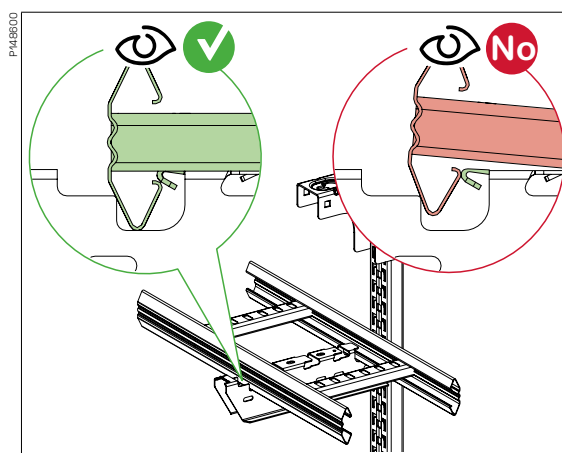
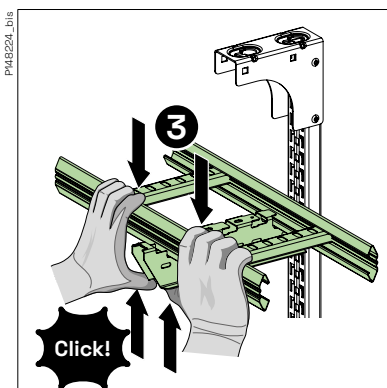

Visually check that the ladder is properly positioned, and the locking lip is positioned inside of the ladder profile.

## Technical information

### Use and installation

#### Uninstallation of KHSZP ladder of cantilever arms

Remove the ladder from the cantilever arm, by using a flat screwdriver.

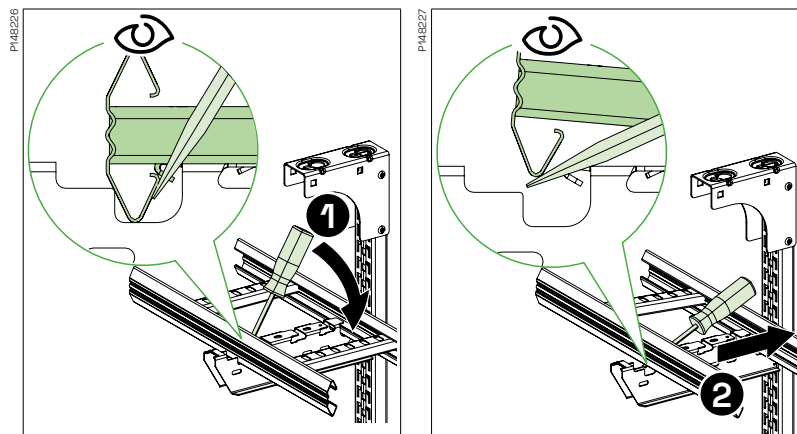

**1** Fit the head of the screwdriver between the ladder and the top surface of the cantilever as in the picture. Use the screwdriver as a lever to pull out the ladder of the locking lip until the ladder snaps out.

After releasing the outer side of the ladder, **2** push the ladder in the direction of the rail to unlock the other side.

#### Installation of Defem mesh trays on cantilever arms

CLX<sup>3</sup> cantilever arms are designed to fix Defem mesh trays, height 60 and 110, without need of tools or bolts.

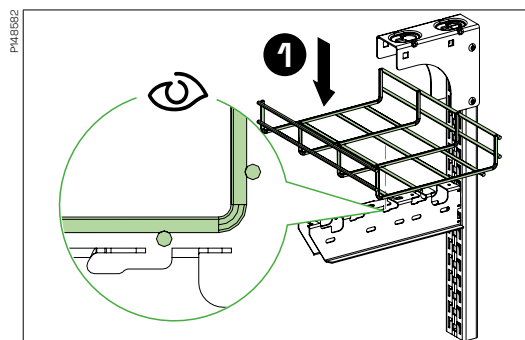

**1** Insert the longitudinal wires in the slots.

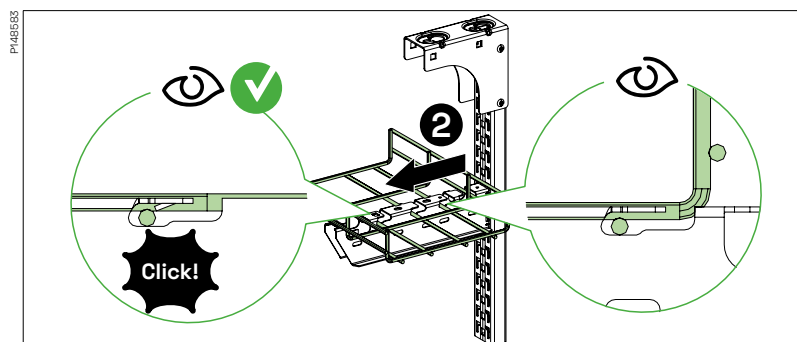

**2** Pull the mesh tray horizontally towards the tip of the cantilever arm until the mesh tray wire passes the locking lip and clicks into position.

Process in the opposite order to dismantle the mesh tray.

## Technical information

### Use and installation

#### Installation of Performa mesh trays on cantilever arms

Performa mesh trays can be fixed to the CLX<sup>3</sup> cantilever arms with bolted couplers. The number of bolted couplers needed depends on the width of the tray.

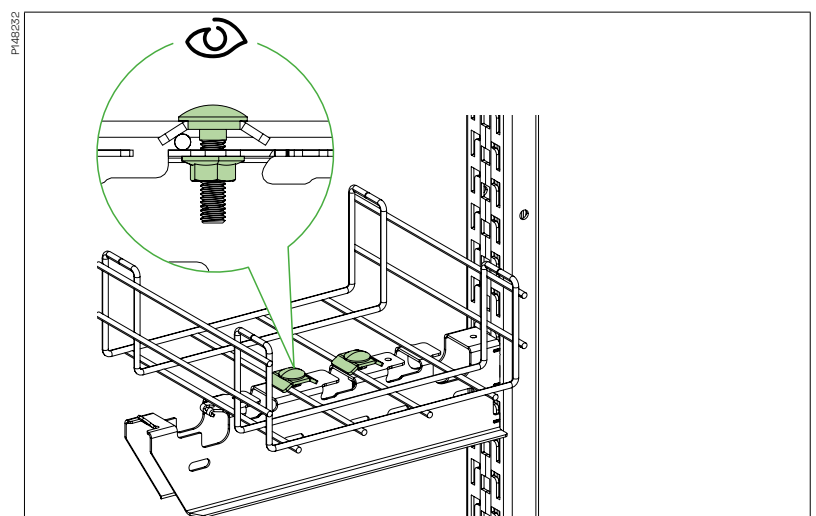
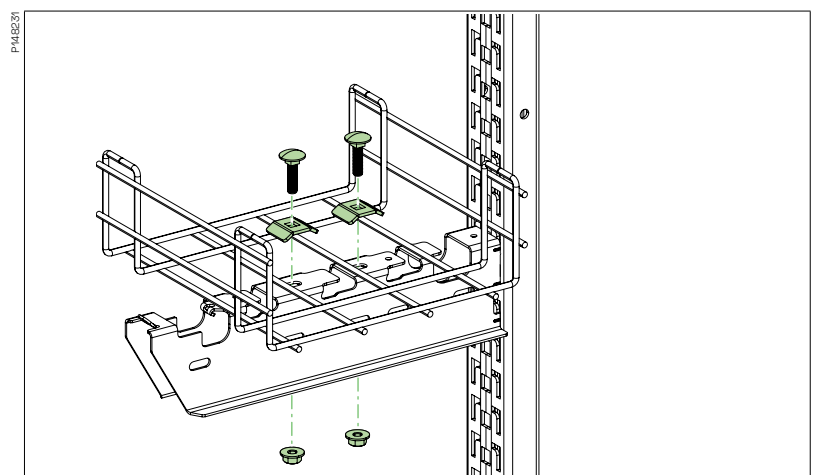
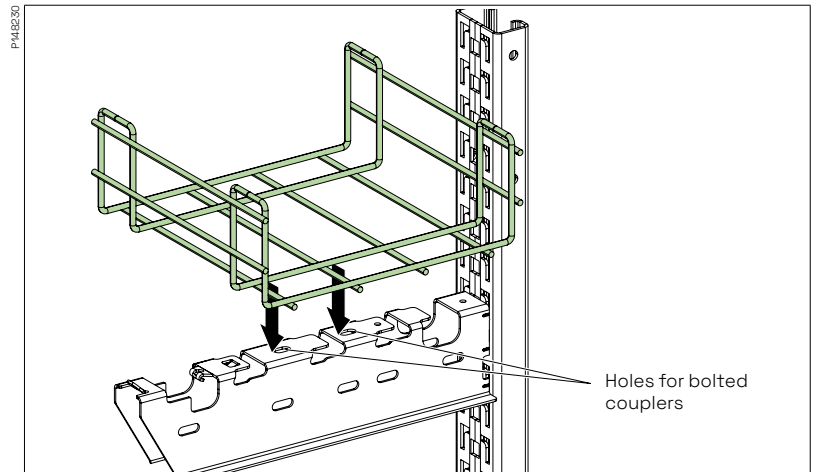

Place the Performa mesh tray on the top surface of the cantilever arm, as close as possible to the rail and by leaving at least 20 mm. Insert the bolts of the couplers on the oblong holes on the top. Tight the nuts under the cantilever arm (**12 N.m**).

# Technical information

## Use and installation

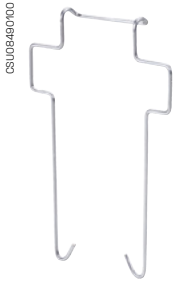

### Installation of Stago cable trays on cantilever arms

CLX<sup>3</sup> cantilever arms are designed to fix Stago cable trays without tool. The fast fixing clamp is used to clip-on the Stago cable trays KG281/KB184/KB284, height 60.

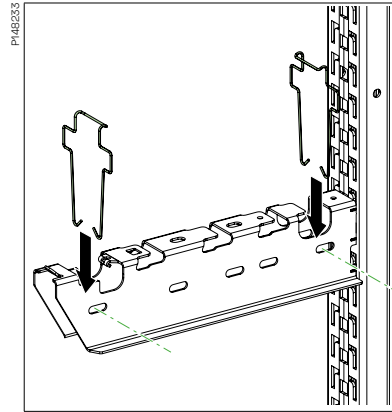

2 fast fixing clamps are required per cantilever.

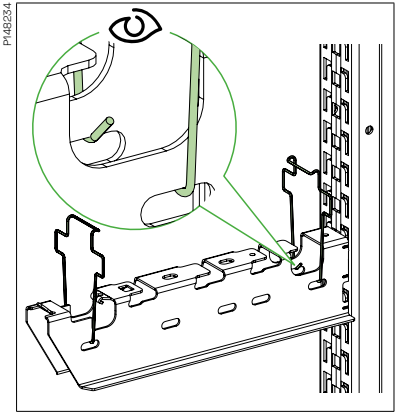

Place the hooks of the clips in the holes on the side of the CLX<sup>3</sup> cantilever arm at the appropriate width for the tray to be fixed.

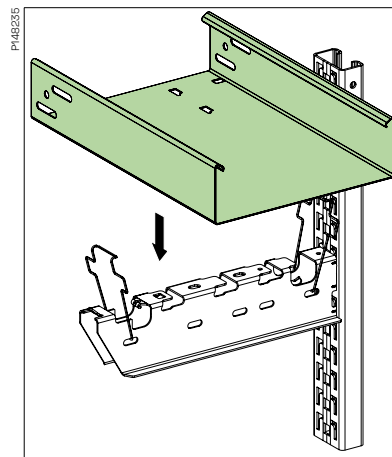

Place the tray on the cantilever arm.

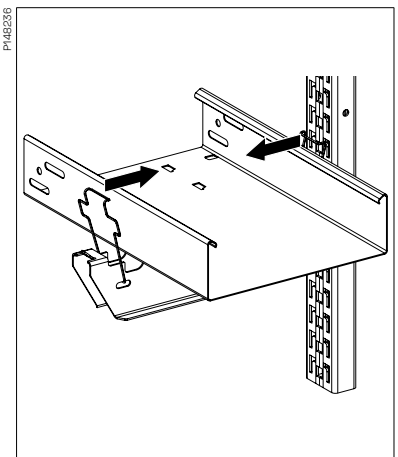

Fix the top of the spring on the top of the tray.

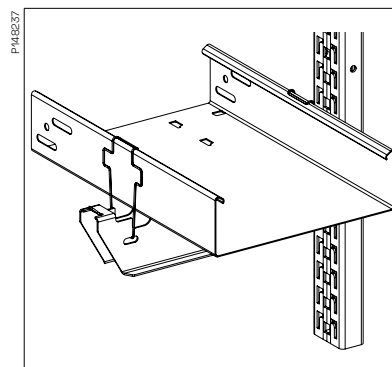

Process in the opposite order to dismantle the cable tray.



## Technical information

### Use and installation



### CLX<sup>3</sup> Central suspension adapter

The CLX<sup>3</sup> central suspension adapter is clicked together with the central suspension brackets to create a central suspension piece that can be clicked to the rail or pendant.

Model	PG	High (mm) A	Width (mm) B	Length (mm) C
CLX <sup>3</sup> Central suspension adapter PG	CSU795700	166	31	39

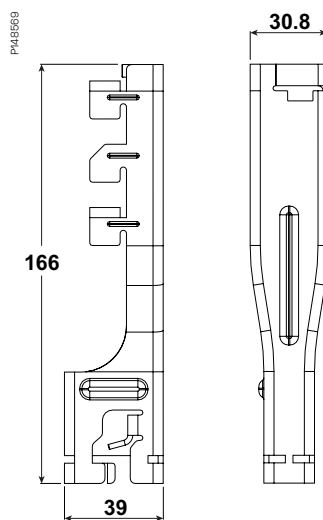

## Technical information

### Use and installation

PT03U-202



### CLX<sup>3</sup> KHZSP ladder central suspension bracket

Bracket to be used for central suspension of KHZSP ladders. The bracket shall be used together with the CLX<sup>3</sup> central suspension adapter.

Model	PG	High mm A	Width mm B	Length mm C
CLX <sup>3</sup> KHZSP central suspension bracket 200 PG	CSU795655	37	78	185
CLX <sup>3</sup> KHZSP central suspension bracket 300 PG	CSU795656	37	78	285
CLX <sup>3</sup> KHZSP central suspension bracket 400 PG	CSU795657	37	78	385
CLX <sup>3</sup> KHZSP central suspension bracket 500 PG	CSU795658	37	78	485
CLX <sup>3</sup> KHZSP central suspension bracket 600 PG	CSU795659	37	78	585

Central suspension bracket	SWL symmetric load (N)
200	1500
300	1500
400	1500
500	1250
600	1200

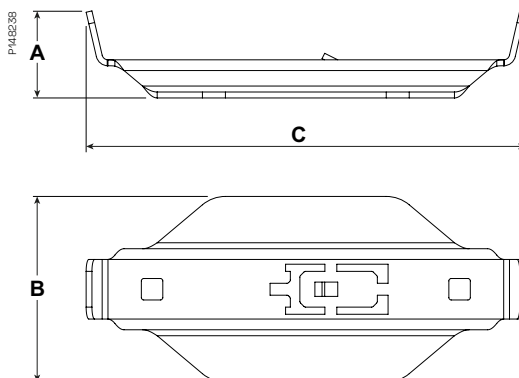

# Technical information

## Use and installation

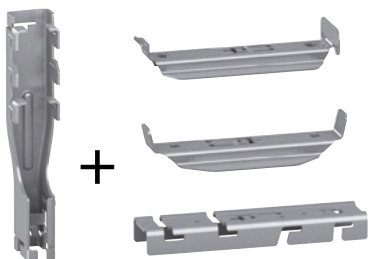

### Installation of adaptor to central suspension brackets

The CLX<sup>3</sup> central suspension bracket is installed without tools by clicking it to the central suspension. The method is the same for Central suspension bracket ladder -mesh or -tray. In the illustration below, the CSB for ladder is used.

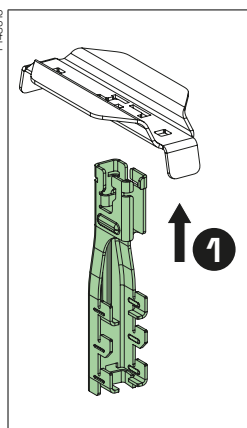

**1** Insert the adaptor in the pattern on the central suspension bracket.

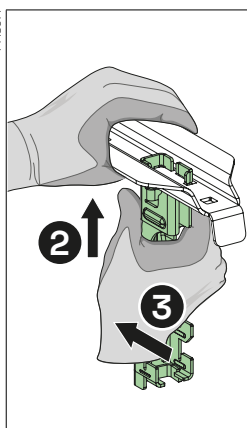

**2** Press the pieces together and **3** slide the adaptor until the click lip of the adaptor pass over the locking lip of the central suspension bracket with a **4** click.

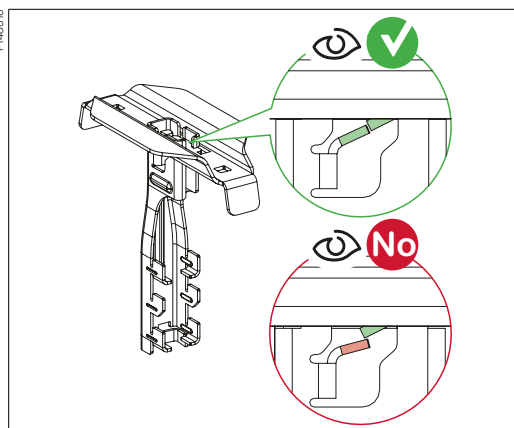
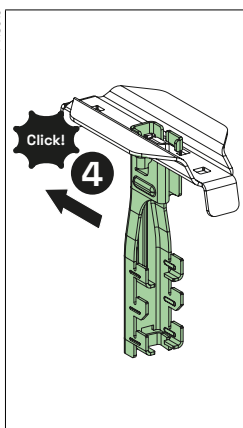

Visually check and secure that the adaptor is properly positioned, and the click lip has overpassed the locking lip.

### Installation of central suspension adaptors to the CLX<sup>3</sup> rail

The CLX<sup>3</sup> central suspension adaptors is installed to the rail without tools, by clicking. To ensure proper installation a hooks must be inserted in the rail.

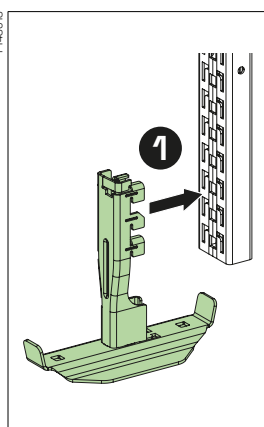

**1** Push the central suspension piece until the hooks are fully inserted in the pattern and the surface touches the rail.

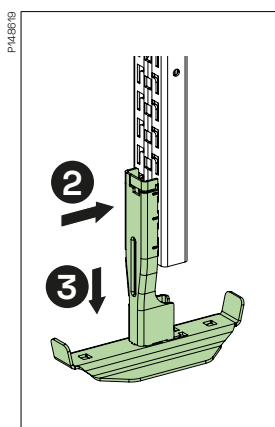

**2** Press towards the rail and **3** pull down until the click lip.

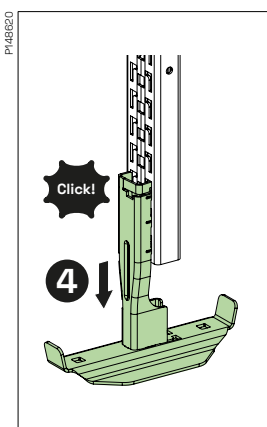

**4** Pass inside the slot in the rail.

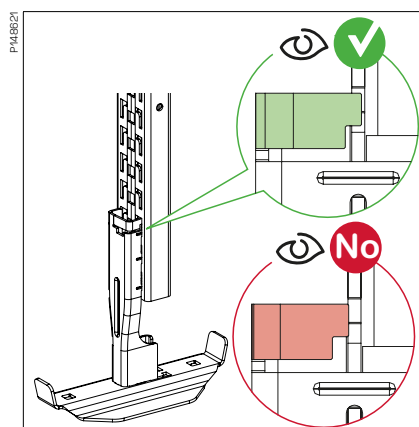

Visually check and secure that the adaptor is properly positioned, and the click lip is properly positioned inside of the slot of the CLX<sup>3</sup> rail.



Apply caution with unintended upward movements as it can cause the adaptor to unlock and therefore be released from the rail

## Technical information

### Use and installation

#### Uninstallation of adapter from the CLX<sup>3</sup> rail

CLX<sup>3</sup> central suspension adapters can be removed, by using a flat screwdriver.

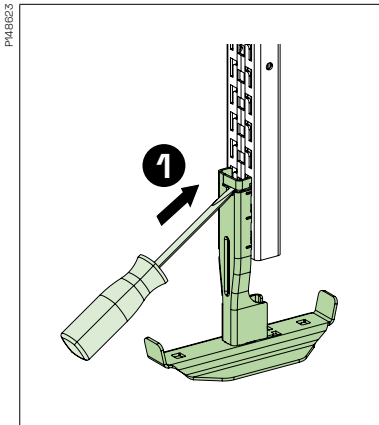

**1** Fit the screwdriver's head in the slot of the adaptor.

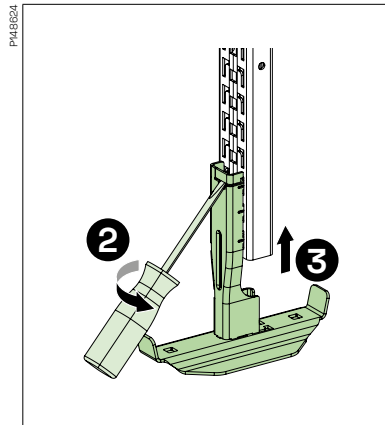

Use the screwdriver as a lever to **2** gently release the click lip from the rail. Then **3** push the adaptor up to release the L hooks from the rail.

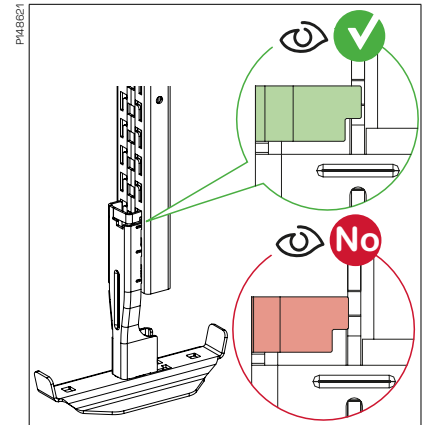

If the adapter needs to be reinstalled, correct the click lip to the initial position and make sure the click lip is locking properly.

#### Uninstallation of adaptor from central suspension brackets

CLX<sup>3</sup> central suspension brackets can be removed, by using a flat screwdriver.

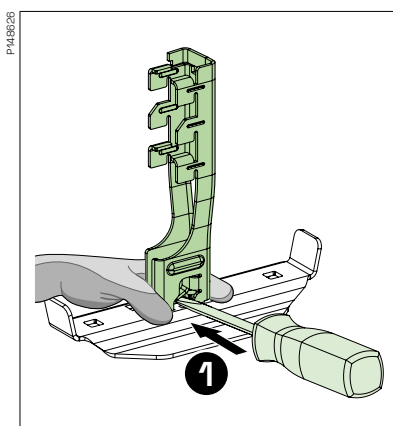

**1** Hold the bracket, fit the screwdriver's head between the adaptor lip and the bracket.

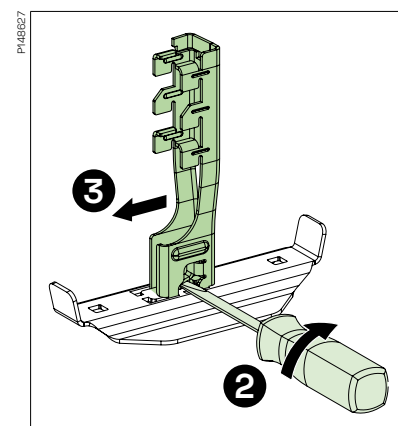

**2** Twist the screwdriver to use it as a lever on the click lip until it passes over the bracket's locking lip and **3** pull the adaptor sideways to release it.

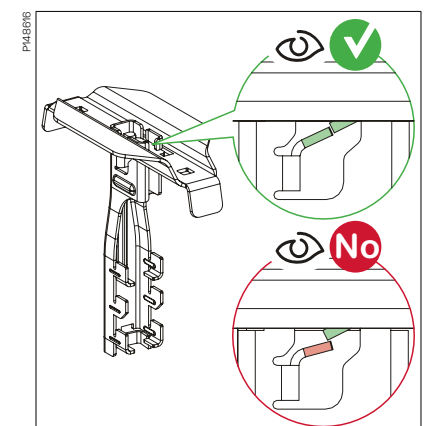

When the bracket needs to be reinstalled, correct the click lip to the initial position and make sure the click lip is locking properly.

# Technical information

## Use and installation

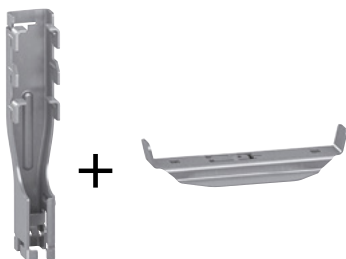

### Installation of KHZSP ladders on central suspension brackets

CLX<sup>3</sup> brackets are made to fix ladders KHZSP without tool.

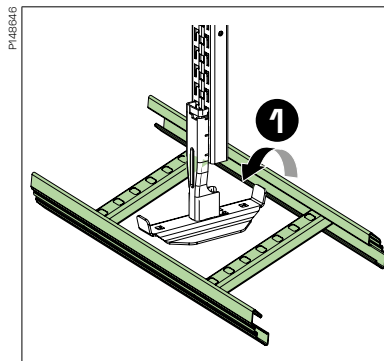

1 Insert one inside side of the ladder on one lips of the bracket.

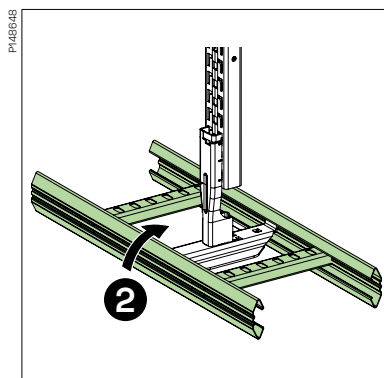
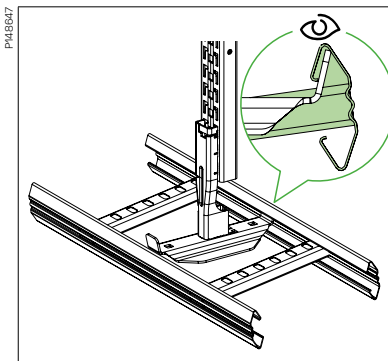

2 Pull up the other side and snap the ladder on the other lip.

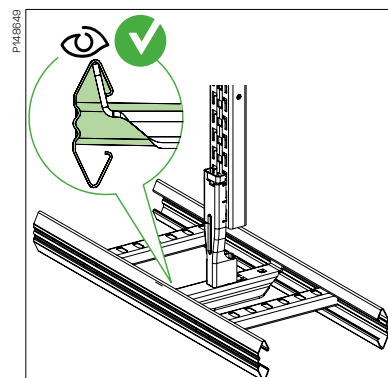

Visually check if the bracket lip is inside the ladder profile. Profile clamp 43 can be used to fix the cable ladder to the support bracket.



Apply caution with unintended upward movements as it can cause the bracket to unlock and therefore be released from the rail

### Uninstallation of KHZSP ladder from the central suspension bracket

KHZSP ladder can be removed from the bracket.

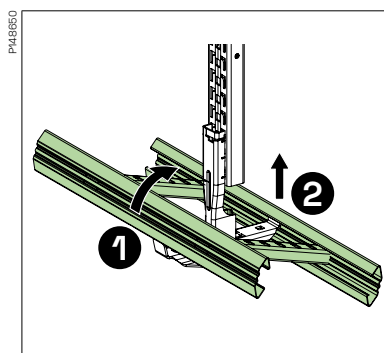

1 Push one side of the ladder up until the ladder leave the lip of the bracket.

2 Release the other side of the ladder from the lip.

# Technical information

## Use and installation



### CLX<sup>3</sup> Cable tray H40 central suspension

Bracket to be used for central suspension of Wibe cable trays, height 40. The bracket shall be used together with the CLX<sup>3</sup> central suspension adapter.

Model	PG	High mm A	Width mm B	Length mm C
CLX <sup>3</sup> Tray H40 central suspension 70 PG	CSU795653	152	37	66
CLX <sup>3</sup> Tray H40 central suspension 100 PG	CSU795654	152	37	96

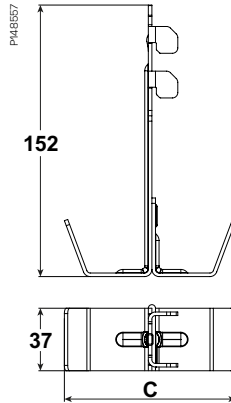

Model	PG	High mm A	Width mm B	Length mm C
CLX <sup>3</sup> Tray H40 central suspension bracket 200 PG	CSU795660	36	76	196
CLX <sup>3</sup> Tray H40 central suspension bracket 300 PG	CSU795661	36	76	296
CLX <sup>3</sup> Tray H40 central suspension bracket 400 PG	CSU795662	36	76	396
CLX <sup>3</sup> Tray H40 central suspension bracket 500 PG	CSU795663	36	76	496
CLX <sup>3</sup> Tray H40 central suspension bracket 600 PG	CSU795664	36	76	596

Tray H40 central suspension bracket	SWL symmetric load (N)
70	1000
100	800
200	1500
300	1500
400	1500
500	1250
600	1200

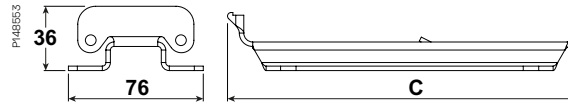

# Technical information

## Use and installation



### Installation of Wibe H40 cable trays on central suspension bracket

CLX<sup>3</sup> central suspension bracket for Wibe cable tray H40, 70 and 100 width is installed to the rail without tools, by clicking.

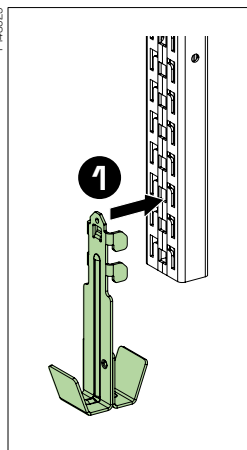

**1** Press the piece until the hooks are fully inserted in the pattern and the surface touches the rail.

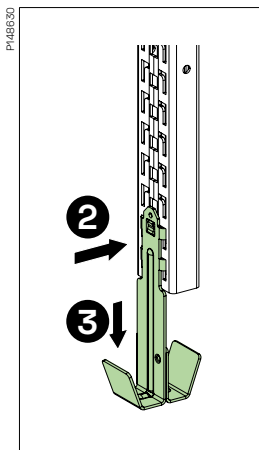

**2** Press towards the rail and **3** pull down until the click lip.

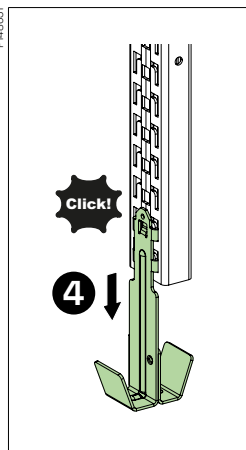

**4** Pass inside the slot in the rail.

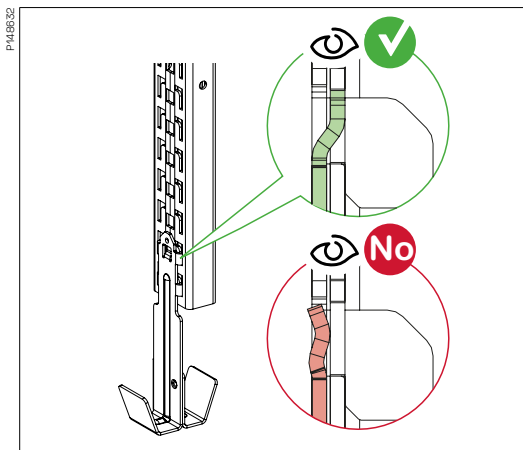

Visually check and secure that the bracket is properly positioned, and the click lip is positioned inside the slot in the CLX<sup>3</sup> rail.



**Apply caution with unintended upward movements as it can cause the bracket to unlock and therefore be released from the rail**

### Uninstallation of Wibe H40 central suspension bracket from the CLX<sup>3</sup> rail

CLX<sup>3</sup> central suspension brackets can be removed, by using a flat screwdriver.

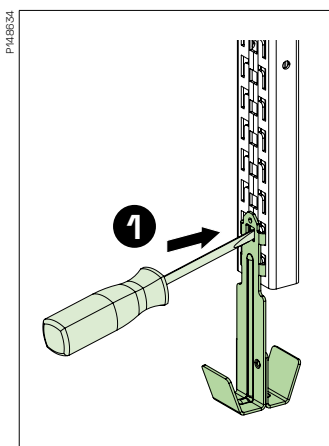

**1** Fit the head of screwdriver on the side of the locking lip.

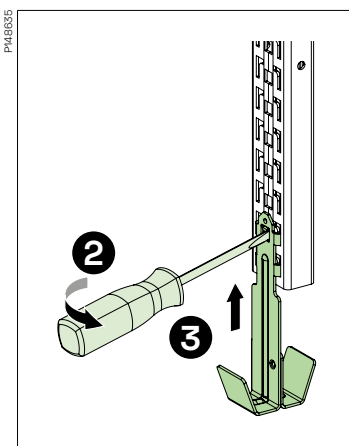

**2** Use the screwdriver as a lever to gently bend the lip. **3** Push the bracket upwards.

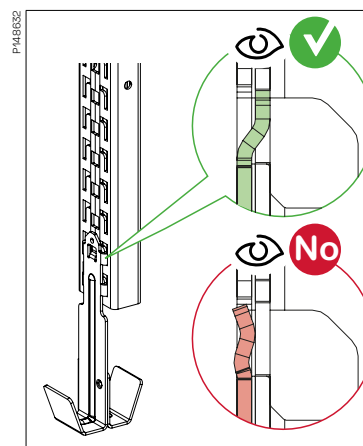

When the bracket needs to be reinstalled, correct the click lip to the initial position and make sure the click lip is locking properly.

## Technical information

### Use and installation

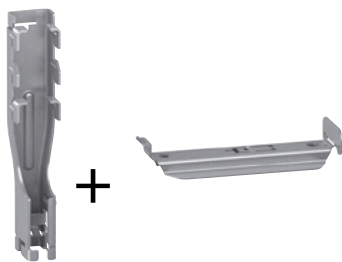

#### Installation of Wibe H40 cable trays on central suspension bracket

CLX<sup>3</sup> brackets are made to fix Wibe cable trays without tool.

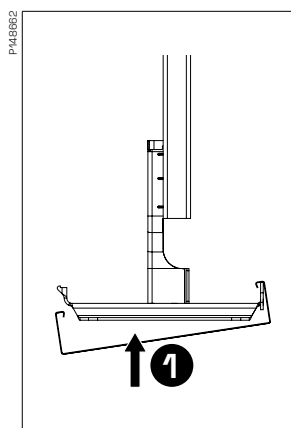

**1** Insert one flange of the tray on the flat lip of the bracket.

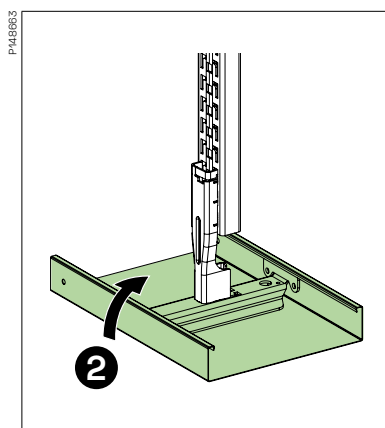

Pull up the other side and **2** snap the tray on the other lip.

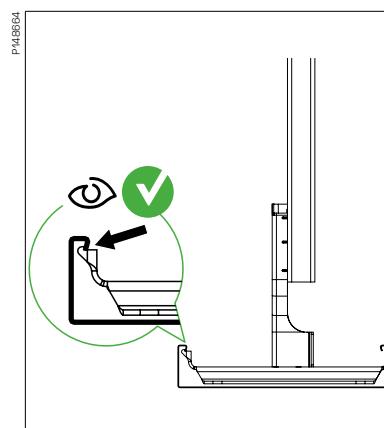

For safety, check if the tray is secured inside the bracket lips.



Apply caution with unintended upward movements as it can cause the tray to unlock and therefore be released from the bracket

#### Uninstallation of Wibe H40 cable tray from central suspension bracket

Wibe cable trays can be remove from the bracket.

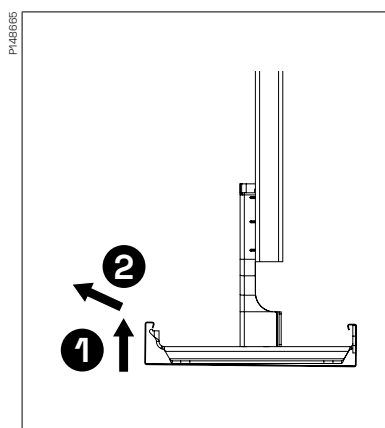

**1** Push the cable tray up on the claw side.  
**2** Pull the cable tray lip out of the bracket.



# Technical information

## Use and installation

PTTOSU-207



PTTOSU-208



### CLX<sup>3</sup> Defem mesh tray central suspension bracket

Bracket to be used for central suspension of Defem mesh trays. The bracket shall be used for mounting Defem mesh trays on vertical pieces.

Model	PG	High mm A	Width mm B	Length mm C
CLX <sup>3</sup> Defem central suspension bracket 120-220 PG	CSU795665	163	31	84
CLX <sup>3</sup> Defem central suspension bracket 320 PG	CSU795666	25	50	206
CLX <sup>3</sup> Defem central suspension bracket 422 PG	CSU795668	25	50	397
CLX <sup>3</sup> Defem central suspension bracket 522-622 PG	CSU795667	25	50	497

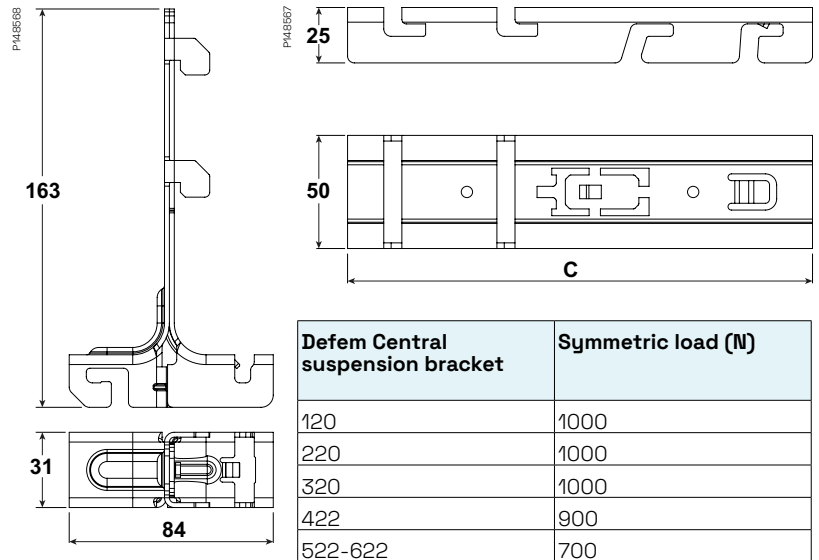

# Technical information

## Use and installation



### Installation of central suspension bracket for Defem mesh tray 120/220

CLX<sup>3</sup> central suspension bracket for Defem 120/220 width don't require tools to be installed.

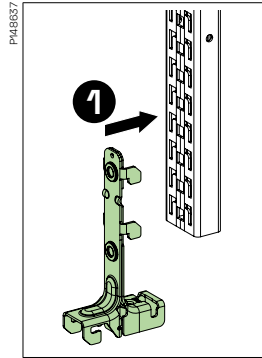

**1** Press the bracket until the hooks are fully inserted in the pattern and the surface touches the rail.

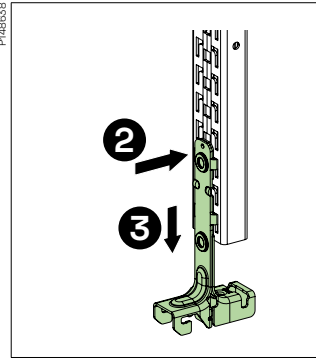

**2** Press against the top of the bracket towards the rail and **3** pull it down until the locking lip go inside the slot in the rail.

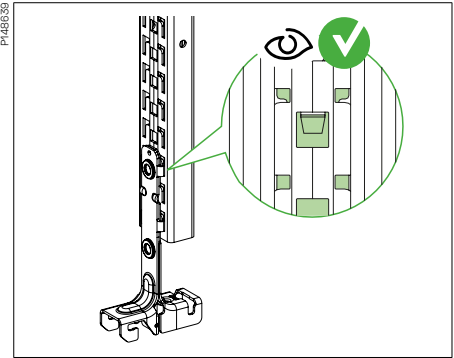

Visually check and secure that the cantilever arm is properly positioned and the locking lip is positioned inside of the slot in the CLX<sup>3</sup> rail.

CLX<sup>3</sup> central suspension bracket for Defem 120/220 can also be installed by using a screwdriver.

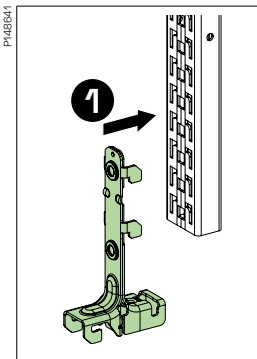

**1** Press the bracket until the hooks are fully inserted in the pattern and the surface touches the rail.

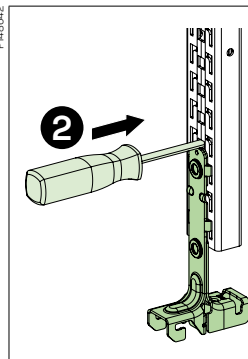

Hold the bracket and **2** insert the screwdriver in the slot just above the bracket.

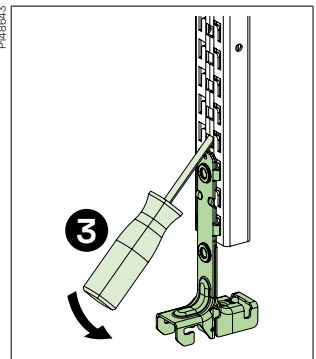

**3** Use the screwdriver as a lever to pull down the bracket until the locking lip go inside the slot in the rail.

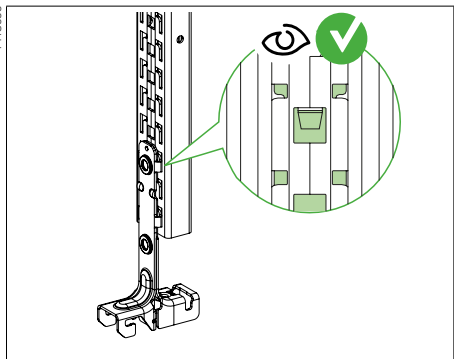

Visually check and secure that the bracket is properly positioned, and the click lip is positioned inside the slot in the CLX<sup>3</sup> rail.

### Uninstallation of central suspension brackets for Defem 120/220 from the CLX<sup>3</sup> rail

CLX<sup>3</sup> central suspension brackets for Defem 120/220 can be removed, by using a flat screwdriver.

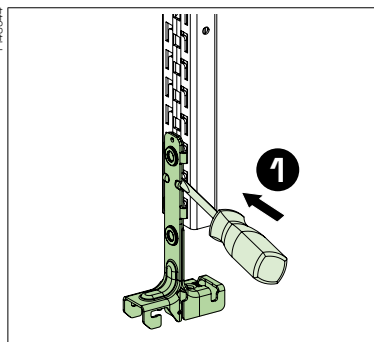

**1** Insert the head of the screwdriver in the bump in the bracket and with the head simultaneously gripping in one of the slots in the rail.

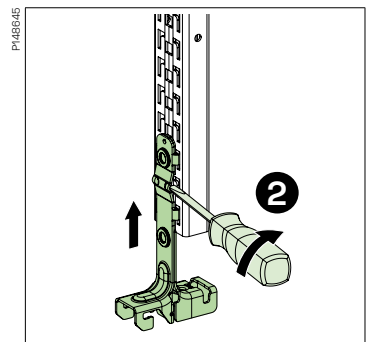

**2** Twist the screwdriver to push the bracket upwards until the bracket is released.

# Technical information

## Use and installation



### Installation of Defem mesh tray on CLX<sup>3</sup> Defem brackets 120/220

P148B55

P148B56

P148B57

P148B58

**1** Insert the longitudinal wire in the down slot, **2** lift and push.

**3** Push down the other wire until it has overpassed the locking lip.

Visually check that the wire is properly positioned, and the wire has passed the locking lip.

### Uninstallation of Defem mesh tray from CLX<sup>3</sup> Defem central suspension bracket 120/220

P148B59

P148B60

**1** Insert the head of the screwdriver above the reinforcement of the bracket and under the mesh tray as showed on the picture.

Hold the bracket and **2** use the screwdriver as a lever until the mesh tray overpass the locking lip.

## Technical information

### Use and installation

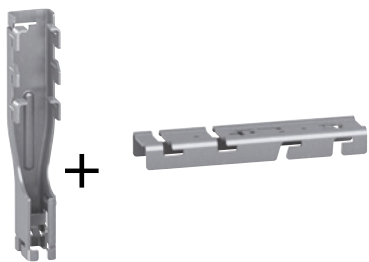

#### Installation of Defem mesh tray on CLX<sup>3</sup> central suspension bracket

CLX<sup>3</sup> brackets are made to fix Defem trays without tool.

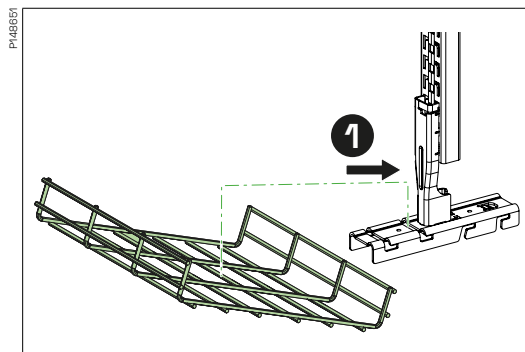

**1** Slide the middle of the mesh tray on the upper slot side of the bracket and insert the longitudinal wire on the most center top slot.

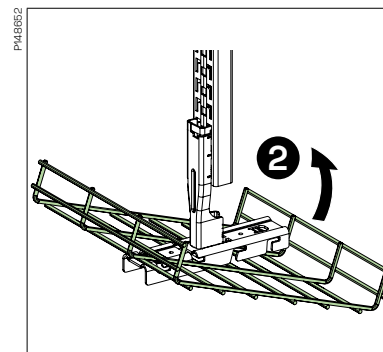

**2** Rotate the tray until all the slots are filled.

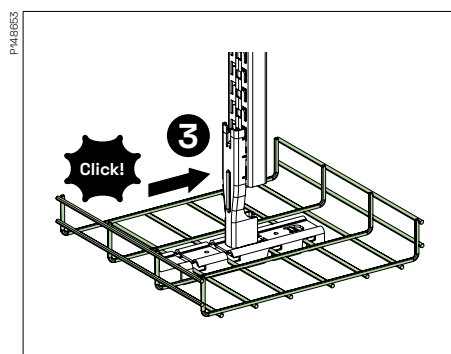

**3** Push the tray to lock it in the bracket.

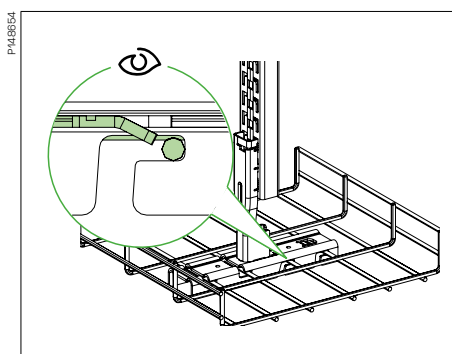

Visually check that the wire is properly positioned and the wire has passed the locking lip.

