

WIBE CABLE TRAYS FOR DEMANDING APPLICATIONS CATALOGUE 2023

Cable support solutions

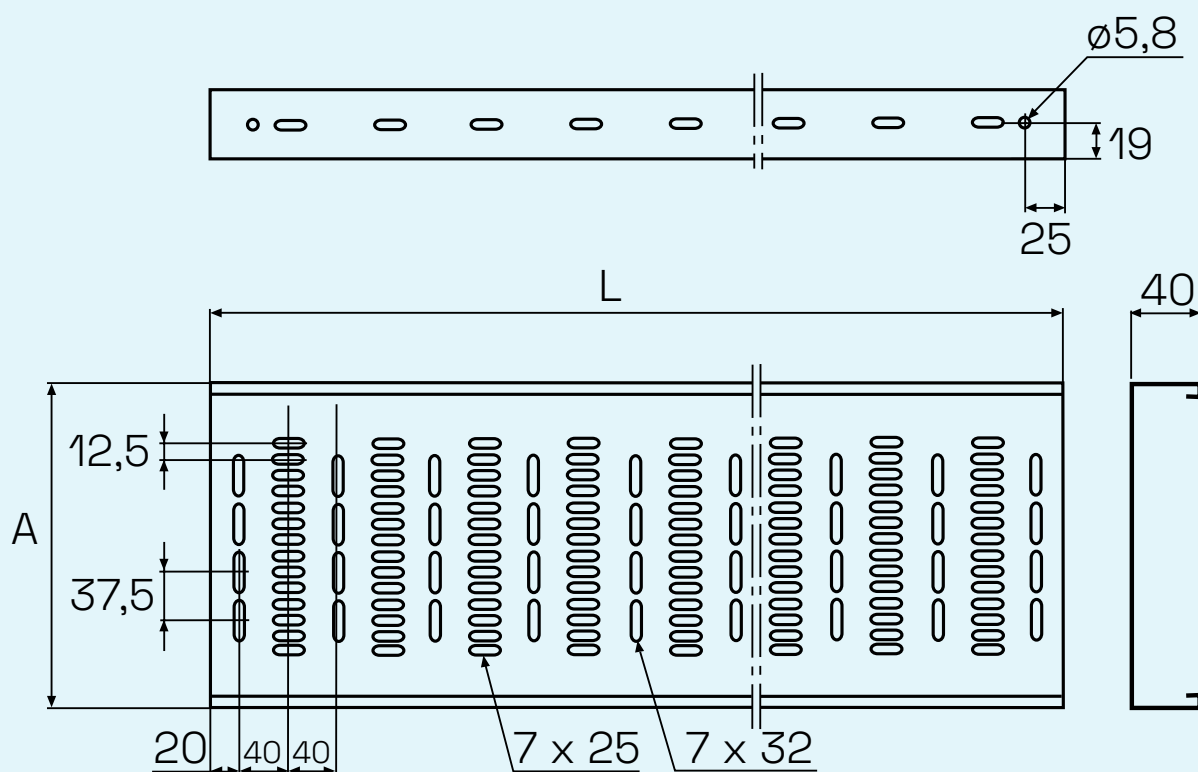

Creating clever, uplifting solutions, together with our clients for almost 100 years. Reimagined in June 2021 – for the coming century.

Looking ahead to the next century, we are reinventing ourselves – as Wibe Group – bringing together four of the world's leading cable management brands as a new independent company to offer a complete, innovative range of cable ladders, cable trays and mesh trays – for applications ranging from commercial buildings to extreme demanding industrial environments.





Wibe Group & sustainability



CO₂ and P&L impact through... Resource Performance

Eco Performance brings improved resource efficiency throughout an asset's lifecycle. This includes efficient use of energy and natural resources, along with the minimization of CO₂ emissions.

Cost of ownership optimization through... Circular Performance

We're helping our customers optimize the total cost of ownership of their assets. To do this, we provide IoT-enabled solutions, as well as upgrade, repair, retrofit, and remanufacture services.

Peace of mind through... Well-being Performance

Eco Performance products are RoHS and REACH compliant. We're going beyond regulatory compliance with step-by-step substitution of certain materials and substances from our products.

Improved sales through... Differentiation

Eco Performance delivers strong value propositions through third-party labels and services. By collaborating with third-party organizations we can support our customers in meeting their sustainability goals such as green building certifications.

Content

Corrosion classes	8
Surface treatments	9
Potential balancing	10
Electro-magnetic compatibility EMC ...	11
Installation regulations	12
Standards and Quality	13
Installation summary	16
Suspension components	16
Steel cable trays	18
Pre-galvanized	18
CLX ³ Click suspension	36
Pre-galvanized white	38
Hot-dip galvanized	54
Zinkpox	64
Stainless steel	74
Technical information	79
Use and installation	79
Reference number overview	158

The right surface treatment – crucial for a successful outcome

A cable support installation is considered to be a long-lasting solution and the life expectancy is dependent on the environment in which it is placed. A thorough investigation of the setting in terms of corrosion, pollution, humidity, salt, sanitary regulations etc will help you make the best choice. Our range of cable ladders and accessories covers all types of surface treatments, enabling a reliable, cost-efficient and long-lasting cable support solution.

C1 Electro-galvanized

Indoor environments: Schools, shops, hotels, offices, sports halls etc.

- Very low environmental corrosion.
- Heated areas.
- Arid atmosphere.
- Insignificant quantities of pollutant.
- ISO 2081

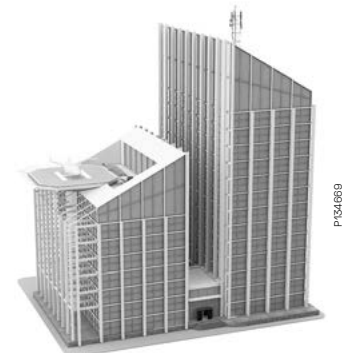

P134669

C2 Pre-galvanized

Partly outdoor environments: Industries, sports halls, warehouses, shops, rural outdoor areas etc.

- Low environmental corrosion.
- Non-heated areas with fluctuating levels of temperature and humidity.
- Few instances of condensation and low levels of airborne pollution.
- SS-EN 10346

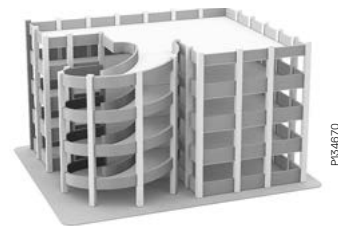

P134670

C3 Hot-dip galvanized

Indoor- and outdoor environments: Urban and light industrial areas, breweries, dairies, laundries etc.

- Average environmental corrosion.
- Areas with average levels of humidity and some airborne pollution caused by production processes.
- Atmospheres containing some salt or average levels of airborne pollution.
- EN-ISO1461/EN 10346 (Z+)

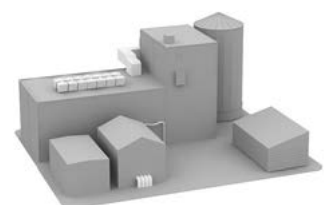

P134671

C4 Hot-dip galvanized

Indoor- and outdoor environments: Chemical plants, industrial and coastal areas, swimming pools, farms, dockyards etc.

- High environmental corrosion.
- Areas with high levels of humidity and considerable airborne pollution.
- Atmospheres with average salt content or discernible levels of airborne pollution.
- EN-ISO1461

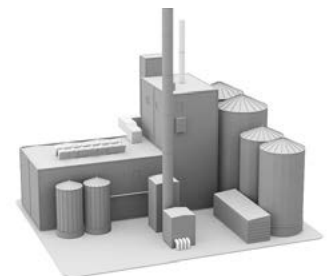

P1344672

C5-I Zinkpox® (Hot dip galv. + powder coated)

Stainless steel AISI 304

Indoor- and outdoor environments: Chemical and heavy industries, tunnels, swimming pools, dockyards etc.

- Very high (industrial) environmental corrosion.
- Areas with almost permanent condensation, large quantities of airborne pollution, high levels of humidity and aggressive atmospheres
- EN 1.4301 acc. to EN 10088/AISI 304



P1344675

C5-M Stainless steel AISI 316L

Indoor- and outdoor environments: Heavy industries, coastal and offshore areas, purifying plants etc.

- Very high (marine) environmental corrosion.
- Areas with almost permanent condensation and large quantities of airborne pollution. Atmospheres with high salt content.
- EN 1.4404 acc. to EN 10088/AISI 316L

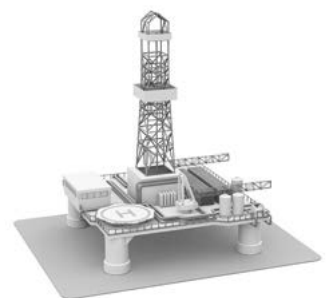

P1344676

Corrosion classes

The life expectancy of a cable support system is dependent on the environment in which it is placed. Therefore, it is important to establish the corrosive properties of an environment to ensure that the right treatment and the right material are chosen. Do not use components finish above of the corrosion class targeted. The table below shows various corrosion classes. As a guide, we have included the surface treatment recommended by Wibe Group for the different classes.

On the next page, we briefly outline the various surface treatments and materials. As regards environmental corrosion, a steel design component can usually be assigned to one of the corrosion classes (C1 to C5-M) as shown in table A. Reference values for the average level of corrosion in steel and zinc are given in table B. The corrosion classes comply with those stipulated in SS-EN ISO 12944-2.

Table A

Corrosion classes as stipulated by SS-EN ISO 12944-2 with atmospheric corrosion levels and examples of the environment in which they are most suitable for use.

Corrosion class	Environmental corrosion	Examples of typical environments in temperate climates (informative)		Wibe Group designation	
		Outdoors	Indoors		
C1	Very low	-	Heated areas with arid atmosphere and insignificant quantities of pollutant, e.g. offices, shops, schools and hotels.	Electro-galvanized DIN 50961/ISO 2081	
C2	Low	Atmospheres with low levels of airborne pollution. Rural areas.	Non-heated areas with fluctuating levels of temperature and humidity. Few instances of condensation and low levels of airborne pollution, e.g. sports halls and warehouses.	Pre-galvanized Z 275 in accordance with SS-EN 10327:2004	
C3	Average	Atmospheres containing some salt or average levels of airborne pollution. Urban and light industrial areas. Areas affected by coastal conditions.	Areas with average levels of humidity and some airborne pollution resulting from production processes, e.g. breweries, dairies, laundries.	Hot-dip galvanized after manufacture in accordance with EN-ISO 1461:2009	Zinc+ coating
C4	High	Atmospheres with average salt content or discernible levels of airborne pollution. Industrial and coastal areas.	Areas of high humidity and considerable airborne pollution as the result of production processes, e.g. chemical plants, swimming pools and dockyards.		
C5-I	Very high (industrial)	Industrial areas with high levels of humidity and aggressive atmospheres.	Areas with almost permanent condensation and large quantities of airborne pollution.	Zinkpox® HDG+powder coating	Thermoplastic coating*
C5-M	Very high (marine)	Coastal and offshore areas with high salt content.	Areas with almost permanent condensation and large quantities of airborne pollution.	Stainless steel SS2333 AISI 304	
				Stainless steel SS2348 AISI 316L	

* Only for Wibe Cable ladders

Table B

Mass losses for steel and zinc in various corrosion classes

Corrosion class	Mass loss per surface unit and thickness reduction (1 year of exposure) ¹			
	Steel		Zinc	
	Mass loss (g/m ²)	Thickness reduction (µm)	Mass loss (g/m ²)	Thickness reduction (µm)
C1	≤ 10	≤ 1.3	≤ 0.7	≤ 0.1
C2	> 10 to 200	> 1.3 to 25	> 0.7 to 5	> 0.1 to 0.7
C3	> 200 to 400	> 25 to 50	> 5 to 15	> 0.7 to 2.1
C4	> 400 to 650	> 50 to 80	> 15 to 30	> 2.1 to 4.2
C5-I	> 650 to 1500	> 80 to 200	> 30 to 60	> 4.2 to 8.4
C5-M	> 650 to 1500	> 80 to 200	> 30 to 60	> 4.2 to 8.4

¹ Corrosion speed is generally higher when the material is first exposed

Surface treatments

Wibe Cable Trays – Technical and material data

Specification:	Cold formed steels: DX5xD acc. to EN 10346, DCOx acc. to EN 10130, DD1x acc. to EN10111 Structural steels: S235 and S355 acc. to EN 10025-2 AISI 316L acc. to EN ISO10088-2
Density:	7.7-7.85 kg/m ³
Surface treatment:	<ul style="list-style-type: none"> • Pre-galvanized (>20 µm): EN 10346 • Pre-galvanized (>20 µm), powder coated white NCS S 0500-N • Hot-dip galvanized (55-70 µm): EN ISO 1461 • Zinkpox, hot-dip galvanized (55-70 µm) + polyester coating, white RAL 9010 • Passivated (Stainless steel)
Resistance to impact	20 J (IEC 61537)
Temperature range	From -40°C to +120°C

Electro-galvanized

Products are manufactured in accordance with DIN 50961/ISO 2081. Such products are intended for use only in warm, dry areas with negligible pollutant levels.

Pre-galvanized

Products are manufactured from Z 275 pre-galvanized sheet steel in accordance with SS-EN 10327:2004. Under normal conditions, surface sections created during cutting and drilling will repair themselves, providing superb anti-corrosion protection.

Hot-dip galvanized

Wibe Group has one of the most modern hot-dip galvanization plants in the Nordic countries. The hot-dip process is continuous, guaranteeing a high and even quality. The manufactured products are hot-dip galvanized in accordance with EN-ISO 1461:2009 whilst nuts and bolts are hot-dip galvanized in accordance with SS-EN ISO 10684:2004. This form of galvanization affords very good value-for-money anti-corrosion protection in atmospheres with a pH value of between 6 and 13. However, in acidic environments where pH levels fall below 6 and in alkaline environments where the pH value exceeds 13, the protective zinc layer breaks down relatively quickly. When cuts/perforations or other kind of operation that damage or remove coating in HDG items suitable to be installed in aggressive corrosion class, must be repaired with a zinc rich paint.

Zinc+

Zinc+ surface treatment for some accessories (EN 10346) with a metallic Zinc-based alloy coating containing Aluminium and Magnesium that offers ultimate corrosion resistance in aggressive environments (e.g. chloride & highly alkaline). In many cases a good alternative to hot-dip galvanization. Excellent surface finish with self-repairing protection of cut edges (galvanic protection).

Zinkpox®

The Zinkpox® method involves applying a homogenous polyester coating to the zinc layer. Besides resisting light-initiated degeneration and weathering, this powder coating has excellent mechanical properties as regards impact resistance and adhesion. It is also resistant to most chemicals. Compared to hot-dip galvanizing, applying a polyester coating to the zinc layer more than doubles the service life of treated components. The zinc layer prevents the development of filiform corrosion. This might otherwise degrade the coating. Consequently, the polyester coating is subject only to atmospheric attack and thus protects the zinc layer. The certified coating plant that treats our components uses a modern and environment-friendly process. Before powder coating, the galvanized components undergo meticulous pre-treatment. This ensures superb adhesion. In addition to extremely good corrosion protection, the Zinkpox® method also offers a choice of colours. Powder coating is a very environment-friendly way of achieving a coloured surface. Because the coating contains no solvents, it has largely replaced solventbased liquid coatings. Where installations are visible, cable trays and fittings can be finished in a coating that matches the surrounding décor.

Thermoplastic coating

An option for corrosive environments. Thermoplastic coating is a thermal process in which a plastic powder is melted to give the component (most usually metal) a special coat. Thermoplastics are predominantly employed in aggressive environments up to and including corrosion class C5-M (ISO 12944-6), where they provide hardwearing, long-lasting and environment-friendly protection against, among other

things, corrosion. Because the coating process is thermal with no solvents, it has minimal impact on the environment. Thermoplastic coatings meet the requirements of the most aggressive environments, e.g. wet, humid environments and those with large temperature variations and concentrations of chemicals. Besides durability, the coatings also have high impact resistance. As the coating provides complete cover, is pore-free and strong, it is also hygienic and dirt repellent. V0 fire rating (UL94), UV resistant.

Stainless steel

Products manufactured in accordance with SS 2333/AISI 304 or SS 2348/AISI 316L are designed for use in highly aggressive environments, either indoors or outdoors, on industrial sites where there are high levels of potent airborne pollution such as in certain chemical industries, cellulose-related industries, refineries or artificial fertilizer factories, high humidity tunnels, etc. Stainless steel products are also ideal for use in environments where special hygiene requirements are in force, such as dairies, abattoirs, other food industries and pharmaceutical factories.

Stainless steel AISI 304 or AISI 316L

The deciding factor in choosing between stainless steel AISI 304 or AISI 316L is the aggressiveness of the environment in which it is to be used, and for this atmospheric chlorine content plays a significant role. Environments with a high chlorine content, coastal areas being a prime example, are aggressive and usually require the use of AISI 316L materials. When assessing the needs of factories, consideration should be given to the materials previously used to suspend equipment such as pipe tubing, and from this determine whether stainless steel AISI 304 or AISI 316L material is required.

To consider when installing Stainless Steel Cable Trays

- 1. Transport/handling:** Make sure that no iron objects come into contact with the stainless steel products.
- 2. Storing:** Never store stainless steel products close to where iron products are machined, for example close to cutting and grinding operations
- 3. Welding:** Welding during installation should be avoided where possible. If welding must be performed, make sure that only methods suitable for stainless steel are used.
- 4. Tools:** When cutting or grinding, always use cutting wheels and grinding tools which are free from iron. Do not use tools that have been previously used for cutting or grinding products containing iron. When drilling, use an HSS-drill. To maximize the useful life of the drill, employ a cooling fluid during drilling. When installing, conventional assembly tools can be used. However, when using a nut tightener, ensure that the thread is first lubricated to prevent jamming. Never mix untreated or galvanized products with stainless steel.
- 5. Measures:** If a blue annealing appears when cutting, grinding or drilling, re-move it with pickling paste, making sure that the paste is then carefully washed away with water. If selective corrosion appears it can be removed by:
 - a) Washing away with water (high-pressure if possible).
 - b) Polishing with a cleaning cloth or a fine emery paper (wet or dry) and washing with water.
 - c) Grinding with a fine-grained wheel and washing with water.
 - d) Pickling with pickling paste, making sure that the pickling paste is then carefully washed away with water.
- 6.** When using pickling paste or similar products, always study the safety code for the product prior to use.

Potential balancing

Electrical continuity and earthing

The standard EN 61537 establishes that for cable trays with electrical continuity characteristics (metal), this continuity should be guaranteed by means of an equipotential connection and one or several connections to earth in accordance with the use of the tray system.

The impedance must not exceed:
 - 50 mΩ through the joint.
 - 5 mΩ x metre of cable trays. (*)
 (*) Currently this value is studied through document IEC/SC23A/WG12, CLC/TC213/WG-5 – 765. It will be changed to 50 mΩ x metre.

The metre length and joining systems for the different sections that Wibe Group has, as well as the joints of the different accessories supplied, comply with the electrical continuity test

established in the aforementioned standard, guaranteeing the impedance established. To guarantee these impedance values tightening torque values of no less than 5 Nm are recommended, always using the joints recommended for each tray type, and taking sizes into account. Ensure that all connections are well fixed and proper values are matching according to local legislation

To guarantee a safe installation, Wibe Group recommends a proper earthing of all the elements that make up the system (sections and accessories), using the accessories designed specifically for this purpose.

WIBE GROUP RECOMMENDS NOT TO USE THE TRAY AS EARTH OR NEUTRAL CONDUCTORS. Wibe Group IS NOT RESPONSIBLE OF ANY DAMAGE IF YOU USE ACCESSORIES FROM OTHER MANUFACTURERS.

Cable trays

Installed with Screw set W38P
 Tightening torque 2 Nm

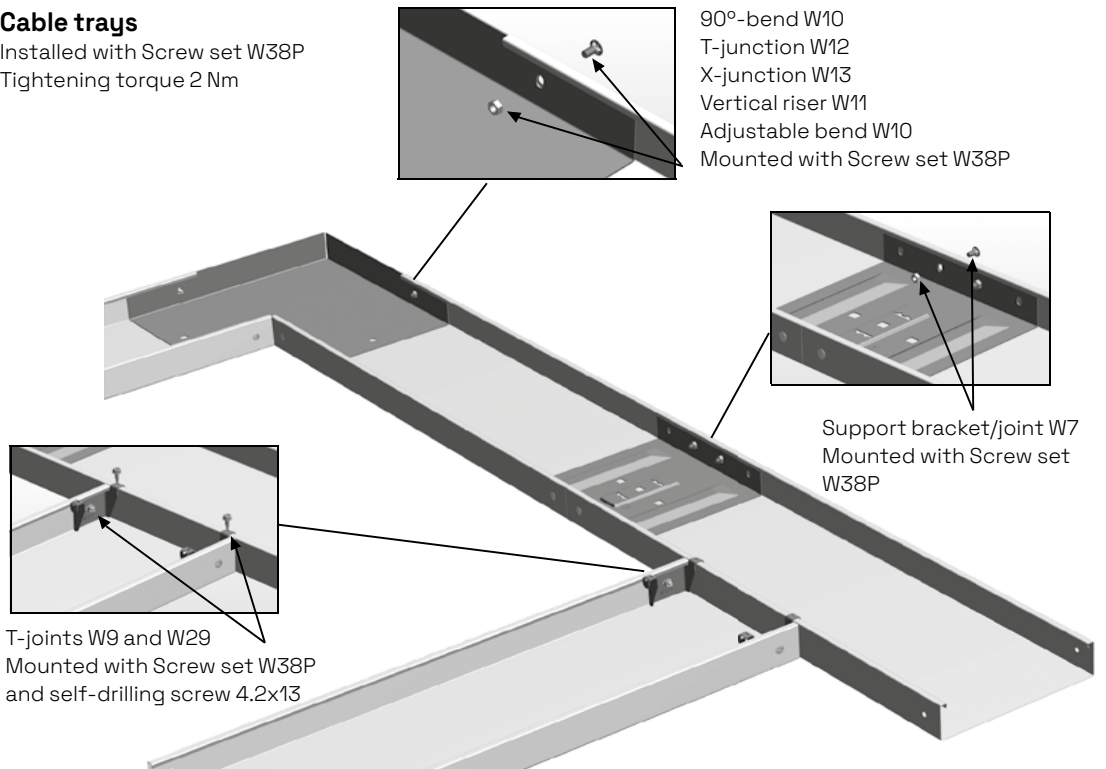

Product	Ohm/m
Cable Tray W1-200, white, with Joint W7, white + Screw set W38P, white	0,0026
Cable Tray W1-200, pre-galv, with Joint W7, pre-galv + Screw set W38P	0,00114
Cable Tray W1-200, pre-galv, with Joint W7, pre-galv + blind rivet	0,00118
Cable Tray W1-200, white, with Joint W7, pre-galv + Screw set W38P, white	0,003
Cable Tray W1-200, white, with Joint W7, pre-galv + blind rivet. (Paint taken away at the blind rivet)	0,00370

Electro-magnetic compatibility EMC

Electromagnetic Compatibility

Wibe Group has performed measurements at EMC Services in Gothenburg regarding EMC requirements, report RE-10273-17181. The results show that the shielding performance of both incoming and emitted fields is good concerning

Wibe cable trays.

When correctly installed Wibe cable trays products work as a protective earth structure. This means that Wibe Group products can be used to achieve good engineering practice in accordance with the EMC directive 2004/108/EG.

Recommended installation examples

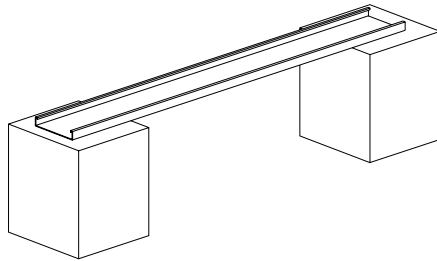

Metal against metal connection
- the ultimate installation

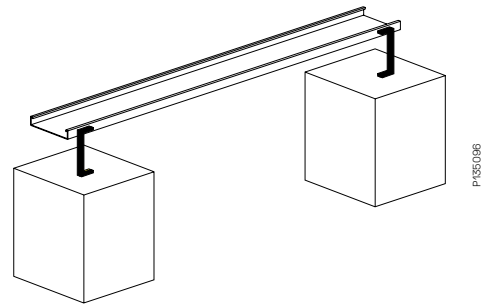

Short double connection
- realistic installation

Not recommended installation examples

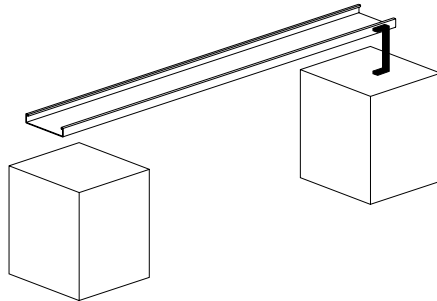

Single connection
- poor installation

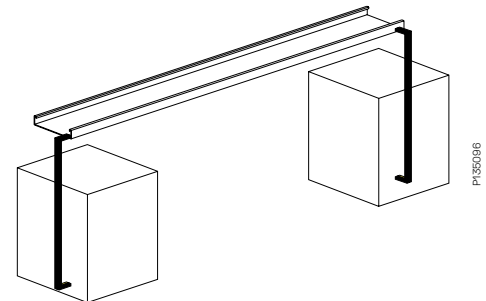

Long double connection
- in best case EMC neutral

Installation regulations

Minimum separation distance (mm), figure A

Recommended cable management

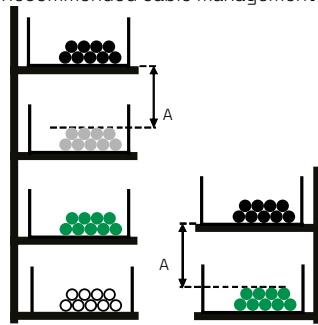

Recommended cable management on common cable tray

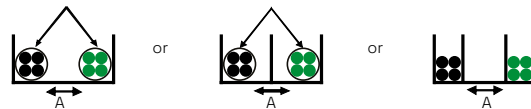

The cables should be fixed to the tray or bunched

- Power cables
- Data cables
- Control cables
- Sensitive cables like instrumentation cables
- A Separation distance

No fixing or bundling needed.

Installation of cable tray

Full design data is given according to EN 61537 in the Range part in this catalogue showing all maximum and recommended loadings. Graphs are given in this catalogue to show the deflection against loading for various support distances. Any support system which is supported at intervals and loaded will deflect between the support intervals. Test model type 1 is used for all cable tray ranges.

Installation recommendations for cable trays

The cable trays should be installed in such a way that, as often as possible, the cables can be laid directly in place rather than being pulled through. Trays for current carrying cables along the ceiling should be installed in such a way that the distance from the top of the tray to the ceiling is not less than 300 mm. The free vertical distance between parallel trays shall be at least 200 mm. Trays near walls should be installed with a minimum free distance of 50 mm to the wall, so that cables can pass between the trays and the wall. Trays along partition walls should be installed with a minimum free distance of 100 mm to the wall. Sharp edges and screw ends on trays should be removed before the cables can be installed. Expansion bolts for the installation of brackets/fixings should be installed with such a distance between them, that the designated load for trays will not be exceeded. When selecting the distance between cantilever arms or brackets/fixings, the bearing strength and designated load of the trays must be taken into consideration.

Standards and Quality



Wibe Cable tray system meets the following standards:

IEC 61537
NEMA VE 1/CSA 22.2

Tests and Certificates

Wibe cable tray is tested according to Underwriters Laboratories, UL E212854.

Wibe cable tray is approved by Det Norske Veritas (DNV) for offshore and ship-yard use Certificate no TAE00000MN.

Test made by

UL, USA & Canada

DNV, Norway

Management system - Quality and Environment

Wibe Group has a third-party certified management system for quality and environment in accordance with OHSASISO 50001:2011, ISO 45001:2018, ISO 9001:2015 and ISO 14001:2015.

CE-marking of products

The CE-marking of products is placed on the product or on the packing according to "Declaration of Conformity" (DOC), applicable to Wibe Group Cable Support System.

Low voltage directive 2014/35/EU

Wibe Group fulfills the demands according to harmonized standard EN 61537.

Installation summary

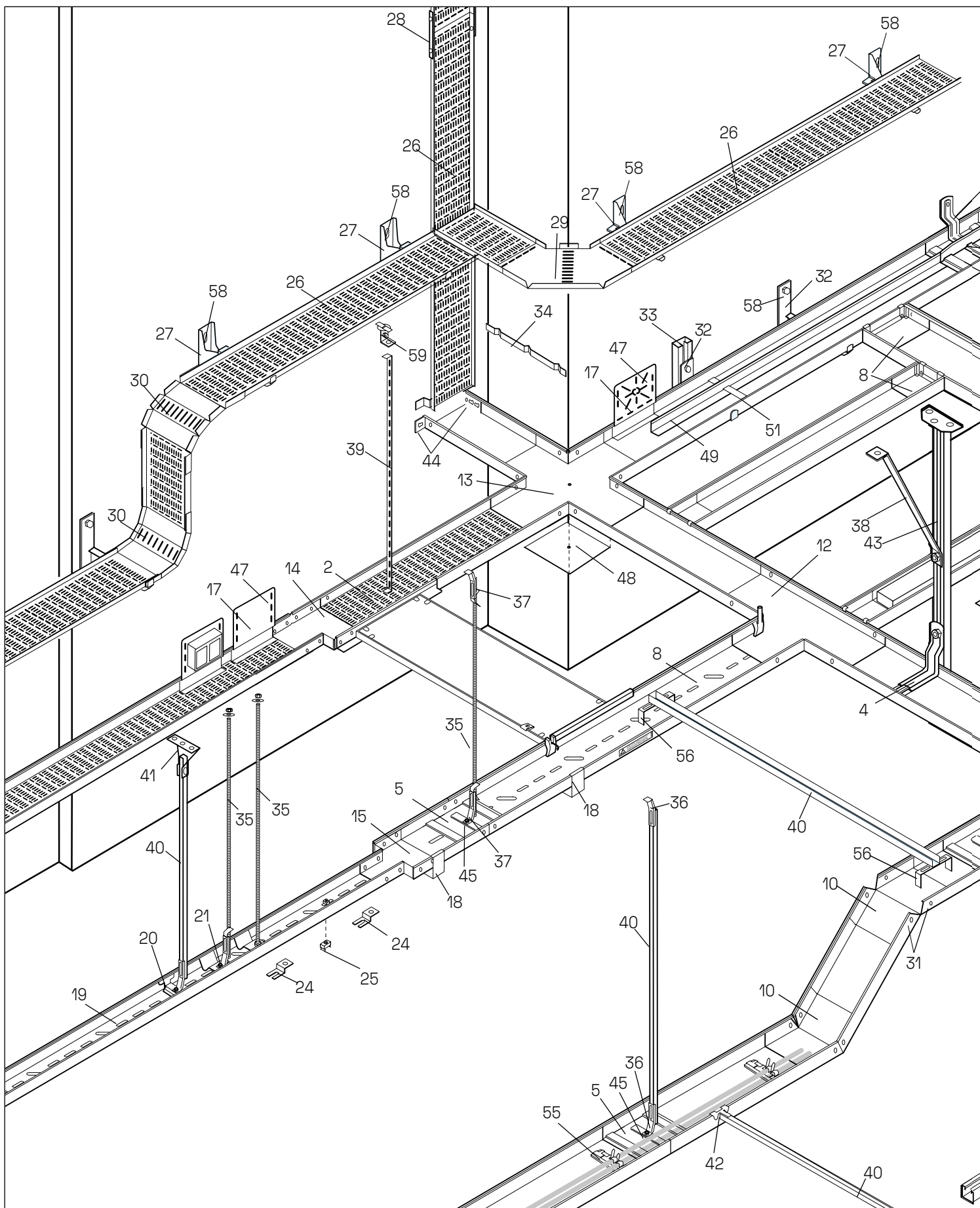

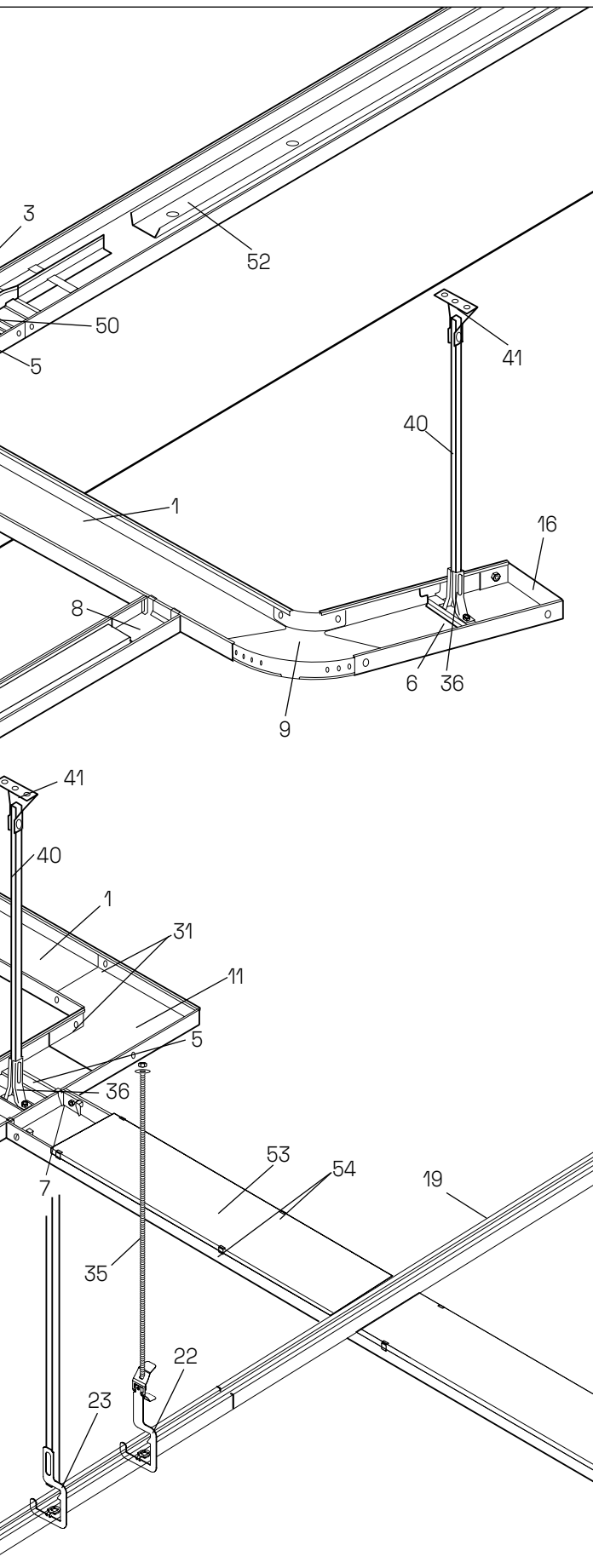

Components

- 1 Cable tray W1/40
- 2 Cable tray W3/40
- 3 Cable tray system W1/60, W3/60 209-231
- 4 Internal cantilever arm W17/40167
- 5 Adjustable cantilever arm W1840 168
- 6 Support bracket/joint W7/40
- 7 Support bracket W1940
- 8 T-joint W9/40
- 9 T-joint W29/40
- 10 Adjustable bend W10/40
- 11 Vertical riser W11/40
- 12 90° bend W10/40
- 13 T-junction W12/40
- 14 X-junction W13/40
- 15 Reducer W28
- 16 Reducer W28
- 17 End cover W45/40
- 18 Junction box plate W24/40
- 19 Luminaire bracket W25/40
- 20 Lighting trunking W70
- 21 Support bracket W20
- 22 Support bracket W20A
- 23 Pendant bracket W80
- 24 Pendant bracket W81
- 25 Luminaire bracket W35
- 26 Luminaire bracket W55
- 27 Installation tray W4
- 28 Cantilever arm 50i, 81
- 29 Joint W2
- 30 90° bend W4
- 31 Vertical riser W4
- 32 Screw set W38P
- 33 Cantilever arm 50
- 34 Mounting rail 40
- 35 Mounting rail WMS15, WMS25
- 36 Threaded rod W76 M6, M8, M10
- 37 Pendant attachment W21
- 38 Tube pendant attachment W73
- 39 Pendant bar 1
- 40 Pendant strip W33
- 41 Pendant rail W32
- 42 Ceiling attachment W31
- 43 Locking clamp W77
- 44 Vertical piece 2F
- 45 Angle bracket W8
- 46 Screw set W36/W36C
- 47 Earth clamp W79
- 48 Cover plate W16
- 49 Dividing strip 39
- 50 Strip fixing W44
- 51 Luminaire bracket W50
- 52 Support band W6
- 53 Cover W5
- 54 Cover clamp W62
- 55 Expansion bolts
- 56 Strip fixing W44
- 57 Luminaire bracket W50
- 58 Expansion bolts
- 59 Fixings-Ogebe

Suspension components

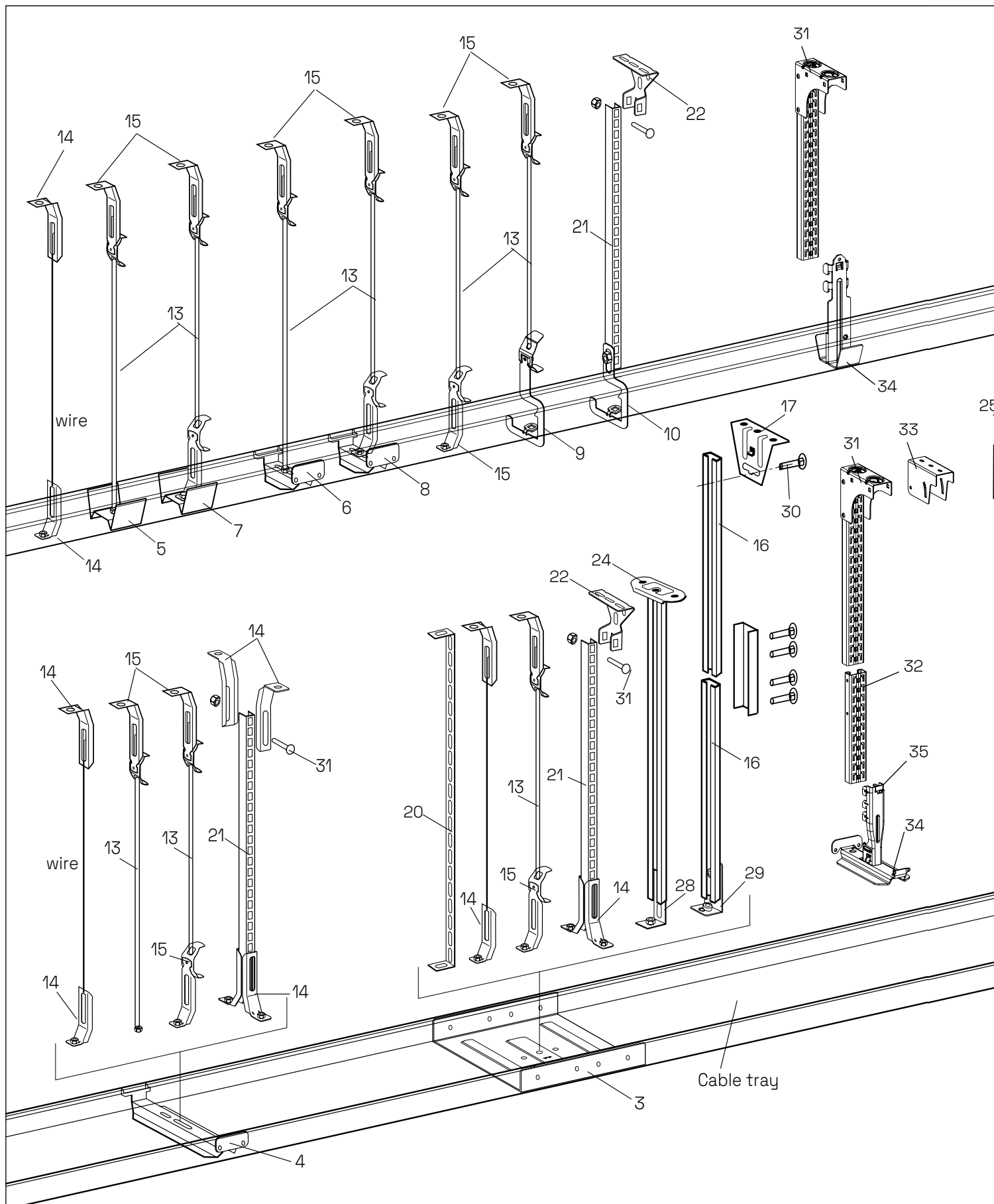

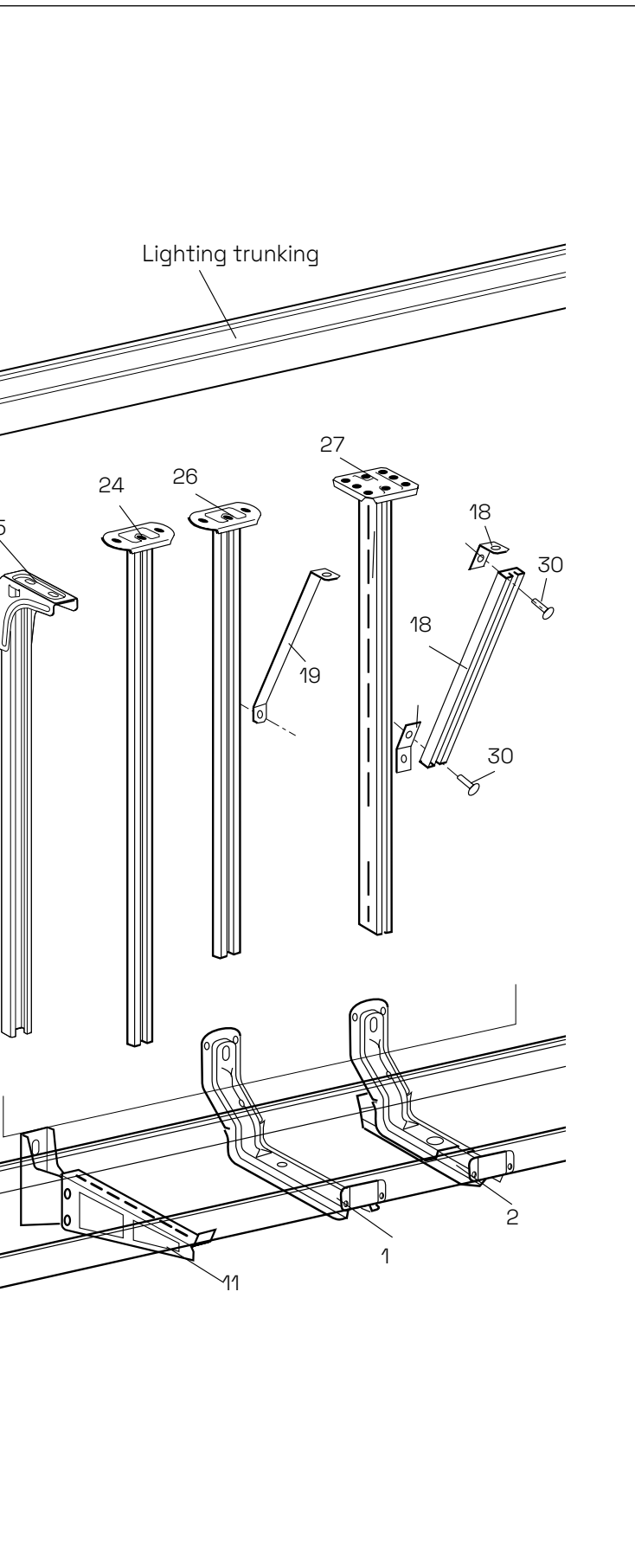



Components

- 1 Internal cantilever arm W17/40
- 2 Adjustable cantilever arm W1840
- 3 Support bracket/joint W7/40
- 4 Support bracket W1940
- 5 Support bracket W20-70
- 6 Support bracket W20-100
- 7 Support bracket W20A-70
- 8 Support bracket W20A-100
- 9 Pendant bracket W80
- 10 Pendant bracket W81
- 11 Cantilever arm 50i
- 13 Threaded rod W76 M6, M8, M10
- 14 Pendant attachment W21
- 15 Tube pendant attachment W73
- 16 Pendant/Fixing rail 24/34
- 17 Ceiling bracket 5
- 18 Bracket 60/40
- 19 Pendant bar 1
- 20 Pendant strip W33
- 21 Pendant rail W32
- 22 Ceiling attachment W31
- 24 Vertical piece 2
- 25 Vertical piece 2Fi
- 26 Vertical piece 2F
- 27 Vertical piece 20
- 28 Angle bracket W8
- 29 Angle bracket W8S
- 30 Screw set 22Sa
- 31 CLX³ Pendant 24/48
- 32 CLX³ Rail 24/48
- 33 CLX³ Adjustable ceiling plate
- 34 CLX³ Central suspension bracket, cable tray H40
- 35 CLX³ Central suspension adapter

Steel cable trays

Pre-galvanized - Corrosion class C2

Cable trays, unperforated

Type	Dimensions A/B/C mm 	Weight kg/100 m	EAN code	Ref. No.	
Cable tray W1					
Unperforated cable tray for indoor applications in dry environments. System height 40 mm. Provided with holes \varnothing 5.8 mm at the tray end to be used for fixation of joints. Material: Steel, pre-galvanized.					
 PTCSU-0002	W1/40-70	40/70/2000	95	7321677132515	713251
		40/70/3000	95	7321677208227	720822
	W1/40-100	40/100/2000	115	7321677132522	713252
		40/100/3000	115	7321677209842	720984
	W1/40-200	40/200/2000	170	7321677132546	713254
		40/200/3000	170	7321677209859	720985
	W1/40-300	40/300/2000	400	7321677132560	713256
		40/300/3000	400	7321677266647	726664
	W1/40-400	40/400/2000	500	7321677132577	713257
		40/400/3000	500	7321677266654	726665
	W1/40-500	40/500/2000	710	7321677132584	713258
		40/500/3000	710	7321677266661	726666
	W1/40-600	40/600/2000	825	7321677232192	723219
		40/600/3000	825	7321677266678	726667
W1/40-500 FS	40/500/2000	715	7321677868315	786831	
W1/40-600 FS	40/600/2000	830	7321677868322	786832	
Unperforated cable tray for indoor applications in dry environments. System height 60 mm. Provided with holes \varnothing 5.8 mm at the tray end to be used for fixation of joints. Material: Steel, pre-galvanized.					
 PTCSU-0002	W1/60-70	60/70/2000	165	7321677819997	781999
	W1/60-100	60/100/2000	185	7321677820009	782000
	W1/60-200	60/200/2000	335	7321677820016	782001
	W1/60-300	60/300/2000	440	7321677239740	723974
	W1/60-400	60/400/2000	540	7321677239757	723975
	W1/60-500	60/500/2000	755	7321677239764	723976
	W1/60-600	60/600/2000	870	7321677239771	723977
	W1/60-500 FS	60/500/2000	760	7321677820467	782046
	W1/60-600 FS	60/200/2000	875	7321677820474	782047

Steel cable trays

Pre-galvanized - Corrosion class C2

Cable trays, perforated

Type	Dimensions A/B/C mm 	Weight kg/100 m	EAN code	Ref. No.
------	--	--------------------	----------	----------

Cable tray W3

Perforated cable tray for indoor applications in dry environments. System height 40 mm. Provided with holes \varnothing 5.8 mm at the tray end to be used for fixation of joints. Oval holes along the lateral side of the tray can be used for mounting of accessories.

Material: Steel, pre-galvanized.



W3/40-50	40/50/3000	103	7321677353880	735388
W3/40-70	40/70/3000	120	7321677353897	735389
W3/40-100	40/100/3000	136	7321677353903	735390
W3/40-150	40/150/3000	170	7321677353910	735391
W3/40-200	40/200/3000	196	7321677353927	735392
W3/40-300	40/300/3000	316	7321677353934	735393
W3/40-400	40/400/3000	390	7321677353941	735394
W3/40-500	40/500/3000	590	7321677353958	735395
W3/40-600	40/600/3000	683	7321677353965	735396

Perforated cable tray for indoor applications in dry environments. System height 60 mm. Provided with holes \varnothing 5.8 mm at the tray end to be used for fixation of joints. Oval holes along the lateral side of the tray can be used for mounting of accessories.

Material: Sheet steel, pre-galvanized.



W3/60-70	60/70/3000	150	7321677822027	782202
W3/60-100	60/100/3000	180	7321677822034	782203
W3/60-150	60/150/3000	200	7321677822041	782204
W3/60-200	60/200/3000	240	7321677822058	782205
W3/60-300	60/300/3000	337	7321677822065	782206
W3/60-400	60/400/3000	440	7321677822072	782207

Installation tray W4

Perforated installation tray for indoor applications in dry environments. To be used when leading cables down from a cable ladder to machine cabinets, etc. Provided with holes \varnothing 3.5 mm in the bottom segment of the tray for the clamping of cables with plate screws.

Material: Steel, pre-galvanized.



W4-50	15/50/1960	57	7321677366033	736603
	15/50/3000	57	7321677359882	735988
W4-75	15/75/1960	76	7321677366040	736604
	15/75/3000	76	7321677359899	735989
W4-100	15/100/1960	93	7321677366057	736605
	15/100/3000	93	7321677359905	735990
W4-150	15/150/1960	125	7321677366064	736606
	15/150/3000	125	7321677359912	735991
W4-200	15/200/1960	195	7321677366071	736607
	15/200/3000	195	7321677359929	735992
W4-250	15/250/1960	228	7321677366088	736608
	15/250/3000	228	7321677359936	735993
W4-300	15/300/1960	238	7321677366095	736609
W4-400	15/400/1960	313	7321677366101	736610

Steel cable trays

Pre-galvanized - Corrosion class C2

Lighting trunking

Type	Dimensions A/B/C mm 	Weight kg/100 m	EAN code	Ref. No.
Lighting trunking W70-50, -70, -100, -200				
Cable tray with bottom perforation for indoor applications in dry environments. System height 40 mm, length 3000 mm. Oval holes 9x5.8 mm on the lateral sides of the tray end can be used for fixation of joints. The oval hole pattern at the base of the tray can be used for mounting of lighting fixtures. On every 500 mm an oval hole is placed to easily guide fast connectors into the tray. Material: Steel, pre-galvanized.				
W70-50	40/50/3000	242	3606480756092	CSU795216
W70-70	40/70/3000	274	3606480410383	CSU794123
W70-100	40/100/3000	323	3606480410345	CSU794124
W70-200	40/200/3000	487	3606480410369	CSU794125

Covers

Cover W5	Weight kg/100 pcs
Cover to be used to protect the cables inside the cable tray against damages, dust, liquids, UV-influence, etc. Material: Sheet steel, pre-galvanized.	
W5-70	100
W5-100	140
W5-150	190
W5-200	250
W5-300	360
W5-400	680
W5-500	840
W5-600	700
Cover clamp W62	
Cover clamp to be used for the fixing of covers on cable trays W1/W3 as well as on lighting trunking W70. Material: Stainless steel 304.	
W62	0.8

Dividers

Dividing strip 39				
Dividing strip to be used to separate power and data communication cables inside a W1/W3 cable tray or W70 lighting trunking. Mounted with Support band 6. Material: Steel, pre-galvanized.				
39/24	24/24/1760	46	7321677188352	718835
39/55	55/24/1750	73	7321677257850	725785
Insert piece W39				
Insert piece to be used to join Dividing strips 39/24 in cable tray W1/W3 and lighting trunking W70/71. The Insert piece can be positioned on Support bracket/joint W7/40 to ensure a continuous separation of cables inside the cable tray. Material: PP, natural coloured.				
W39	37/-/330	3	7321677168248	716824
Insert piece W39/55				
Insert piece to be used to join Dividing strips 39/55 in Cable trays W1/60 or W3/60. The insert piece can be positioned on Support bracket/joint W7/60 to ensure a continuous separation of cables inside the cable tray. Material: Sheet steel, pre-galvanized.				
W39/55	54/4.4/400	19	7321677822997	782299

Dividers

Support band W6				
Support band to be placed inside cable trays to fix the lateral position of one or several Dividing strips W39. The holes in the support band and the locking pins in Dividing strip W39 enable an adjustment of the lateral positioning of the dividing strip with an interval of 25 mm. Material: Sheet steel, pre-galvanized.				
W6-70	-/18/67	1.0	7321677188284	718828
W6-100	-/18/97	1.4	7321677188291	718829
W6-200	-/18/197	2.8	7321677188307	718830
W6-300	-/18/297	4.3	7321677188314	718831
W6-400	-/18/397	5.7	7321677188321	718832
W6-500	-/18/497	7.2	7321677188338	718833
W6-600	-/18/597	8.6	7321677188345	718834

Steel cable trays

Pre-galvanized - Corrosion class C2

Joints		Type	Dimensions A/B/C mm		Weight kg/100 pcs	EAN code	Ref. No.
Support bracket/joint W7							
To be used as a support bracket or joint for cable tray W1/40, W3/40 and for lighting trunking W70. When joining cable tray W1/40 FS (reinforced), side joint W49/40 must be used. Material: Sheet steel, pre-galvanized.							
782212		W7/40-50	38/48/200		14	7321677345540	734554
40-50							
PTCSU-0008		W7/40-70	38/68/200		16	7321677208258	720825
W7/40-100		W7/40-100	38/98/200		25	7321677170210	717021
40-70, 100							
782212		W7/40-150	38/148/200		35	7321677345557	734555
40-150							
PTCSU-0008		W7/40-200	38/198/200		43	7321677170227	717022
W7/40-300		W7/40-300	38/297/300		110	7321677170234	717023
W7/40-400		W7/40-400	38/397/300		140	7321677170241	717024
40-200, 300, 400							
782212		W7/40-500	38/498/300		170	7321677209903	720990
W7/40-600		W7/40-600	38/598/300		200	7321677231805	723180
40-500, 600							
PTCSU-0008		To be used as a support bracket or joint for cable tray W1/60, W3/60. When joining cable tray W1/60 FS (reinforced), side joint W49/60 must be used. Material: Sheet steel, pre-galvanized.					
W7/60-70		W7/60-70	58/68/152		22	7321677822096	782209
W7/60-100		W7/60-100	58/98/200		33	7321677184453	718445
W7/60-150		W7/60-150	58/148/200		41	7321677822102	782210
60-70, 100							
782212		W7/60-200	58/198/200		49	7321677184460	718446
W7/60-300		W7/60-300	58/297/300		122	7321677184477	718447
W7/60-400		W7/60-400	58/397/300		152	7321677184484	718448
60-200, 300, 400							
782212		W7/60-500	58/498/300		180	7321677822119	782211
W7/60-600		W7/60-600	58/598/300		210	7321677822126	782212
60-500, 600							
PTCSU-0008		Side joint W49					
Side joint to be used for straight joining of cable tray W1/40 and W3/40. Material: Sheet steel, pre-galvanized.							
W49/40		W49/40	37.5/-/300		17	7321677868353	786837
W49/60		W49/60	58/-/300		27	7321677822676	782267
60-70, 100							
PTCSU-0021		Flexible coupler W3-40					
Side joint to be used for straight joining of cable tray W3/40 and can also be used to create T-junctions, X-junctions, reducers (left, right and straight), horizontal bends, vertical risers and direct mounting suspension strips. Material: Sheet steel, zinc+ treatment.							
W3/40		W3/40	36/2/300		12	3606480788987	CSU795136
60-150							
PTCSU-0008							
60-200, 300, 400							
782212							
60-500, 600							
PTCSU-0022							

Steel cable trays

Pre-galvanized - Corrosion class C2

Joins

Type	Dimensions A/B/C mm		Weight kg/100 pcs	EAN code	Ref. No.
------	------------------------	---	----------------------	----------	----------

Joint W2

Side joint to be used for straight joining of installation tray W4.
Material: Sheet steel, pre-galvanized.

W2	15/25/200		8	7321677885725	788572
----	-----------	--	---	---------------	---------------

PTCSU-0023



T-joint W9

T-joint to be used to construct T-sections or X-sections. Also used for oblique branches. The ref. number includes two pieces of T-joints and Screw set W38P.
Material: Sheet steel, pre-galvanized.

W9/40	40/72.5/20		6	7321677182053	718205
-------	------------	--	---	---------------	---------------

718205



W9/60	60/72.5/20		5	7321677822171	782217
-------	------------	--	---	---------------	---------------

782217



T-joint W29

T-joint to be used to construct T-junctions or X-junctions. Easy push-in assembly. Locks into the tray via locking flap. To be suspended over the lateral side of the tray and locked in a suitable way.
Material: Sheet steel, pre-galvanized.

W29/40-70	38/67/68		8	7321677909841	790984
-----------	----------	--	---	---------------	---------------

790988



W29/40-100	38/67/98		12	7321677909858	790985
------------	----------	--	----	---------------	---------------

W29/40-200	38/67/198		21	7321677909865	790986
------------	-----------	--	----	---------------	---------------

W29/40-300	38/67/301		30	7321677909872	790987
------------	-----------	--	----	---------------	---------------

W29/40-400	38/67/401		40	7321677909889	790988
------------	-----------	--	----	---------------	---------------

W29/40-500	38/67/501		50	7321677909896	790989
------------	-----------	--	----	---------------	---------------

W29/40-600	38/67/601		59	7321677909902	790990
------------	-----------	--	----	---------------	---------------

T-joint to be used to construct T-junctions or X-junctions. Easy push-in assembly. Locks into the tray via locking flap. To be suspended over the lateral side of the tray and locked in a suitable way.
Material: Sheet steel, pre-galvanized.

W29/60-70	58/67/68		22	7321677831784	783178
-----------	----------	--	----	---------------	---------------

783180



W29/60-100	58/67/98		27	7321677831791	783179
------------	----------	--	----	---------------	---------------

W29/60-200	58/67/198		37	7321677831807	783180
------------	-----------	--	----	---------------	---------------

W29/60-300	58/67/298		47	7321677831814	783181
------------	-----------	--	----	---------------	---------------

W29/60-400	58/67/398		57	7321677831821	783182
------------	-----------	--	----	---------------	---------------

W29/60-500	58/67/498		67	7321677831838	783183
------------	-----------	--	----	---------------	---------------

W29/60-600	58/67/598		77	7321677831845	783184
------------	-----------	--	----	---------------	---------------

Steel cable trays

Pre-galvanized - Corrosion class C2

Bends

Type	Dimensions A/B/C mm		Weight kg/100 pcs	EAN code	Ref. No.
------	------------------------	---	----------------------	----------	----------

90° bend W10

Horizontal 90° bend to be used for cable trays W1/40 and W3/40. Push-in assembly. Material: Sheet steel, pre-galvanized.

P49352



W10/40-50 (flat)	38/183/183		14.9	3606480994937	CSU795379
------------------	------------	--	------	---------------	------------------

717905



W10/40-70	38/167/167		38	7321677179039	717903
-----------	------------	--	----	---------------	---------------

W10/40-100	38/197/197		51	7321677179046	717904
------------	------------	--	----	---------------	---------------

W10/40-150	38/247/247		75	7321677334803	733480
------------	------------	--	----	---------------	---------------

W10/40-200	38/297/297		108	7321677179053	717905
------------	------------	--	-----	---------------	---------------

W10/40-300	38/397/397		185	7321677179060	717906
------------	------------	--	-----	---------------	---------------

W10/40-400	38/497/497		281	7321677179077	717907
------------	------------	--	-----	---------------	---------------

W10/40-500	38/597/597		400	7321677211845	721184
------------	------------	--	-----	---------------	---------------

W10/40-600	38/697/697		540	7321677231966	723196
------------	------------	--	-----	---------------	---------------

782041



Horizontal 90° bend to be used for cable trays W1/60 and W3/60. Push-in assembly. Material: Sheet steel, pre-galvanized.

W10/60-70	58/167/167		43	7321677820382	782038
-----------	------------	--	----	---------------	---------------

W10/60-100	58/197/197		55	7321677820399	782039
------------	------------	--	----	---------------	---------------

W10/60-150	58/247/247		85	7321677820405	782040
------------	------------	--	----	---------------	---------------

W10/60-200	58/297/297		117	7321677820412	782041
------------	------------	--	-----	---------------	---------------

W10/60-300	58/397/397		196	7321677820429	782042
------------	------------	--	-----	---------------	---------------

W10/60-400	58/497/497		295	7321677820436	782043
------------	------------	--	-----	---------------	---------------

W10/60-500	58/597/597		413	7321677820443	782044
------------	------------	--	-----	---------------	---------------

W10/60-600	58/697/697		551	7321677820450	782045
------------	------------	--	-----	---------------	---------------

W10/60-500 FS	58/597/597		343	7321677824588	782458
---------------	------------	--	-----	---------------	---------------

W10/60-600 FS	58/697/697		465	7321677824595	782459
---------------	------------	--	-----	---------------	---------------

Adjustable bend W10S

Adjustable bend to be used for horizontal angling from 105° to 165° in steps of 7.5°. Push-in assembly. Material: Sheet steel, pre-galvanized.

PTCSU-0024



W10S/40-50	38/47/47		9	7321677345847	734584
------------	----------	--	---	---------------	---------------

W10S/40-70	38/67/67		10	7321677168330	716833
------------	----------	--	----	---------------	---------------

W10S/40-100	38/97/97		13	7321677168347	716834
-------------	----------	--	----	---------------	---------------

W10S/40-150	38/147/147		24	7321677345854	734585
-------------	------------	--	----	---------------	---------------

W10S/40-200	38/197/197		40	7321677168354	716835
-------------	------------	--	----	---------------	---------------

W10S/40-300	38/297/297		75	7321677168361	716836
-------------	------------	--	----	---------------	---------------

W10S/40-400	38/397/397		125	7321677168378	716837
-------------	------------	--	-----	---------------	---------------

W10S/40-500	38/497/497		270	7321677249657	724965
-------------	------------	--	-----	---------------	---------------

W10S/40-600	38/597/597		380	7321677249664	724966
-------------	------------	--	-----	---------------	---------------

PTCSU-0025



Adjustable bend to be used for horizontal angling from 105° to 165° in steps of 7.5°. Push-in assembly. Material: Sheet steel, pre-galvanized.

W10S/60-70	58/67/67		17	7321677822683	782268
------------	----------	--	----	---------------	---------------

W10S/60-100	58/97/97		23	7321677822690	782269
-------------	----------	--	----	---------------	---------------

W10S/60-150	58/147/147		37	7321677822706	782270
-------------	------------	--	----	---------------	---------------

W10S/60-200	58/197/197		53	7321677822713	782271
-------------	------------	--	----	---------------	---------------

W10S/60-300	58/297/297		97	7321677822720	782272
-------------	------------	--	----	---------------	---------------

W10S/60-400	58/397/397		156	7321677822737	782273
-------------	------------	--	-----	---------------	---------------

W10S/60-500	58/497/497		292	7321677822744	782274
-------------	------------	--	-----	---------------	---------------

W10S/60-600	58/597/597		406	7321677822751	782275
-------------	------------	--	-----	---------------	---------------

90° bend W4

Horizontal 90° bend to be used for cable tray W4. To be mounted on the outside of the tray and attached in the bottom segment with screw set W34. Material: Sheet steel, pre-galvanized.

784077



W4-50	16/52/-		10	7321677840731	784073
-------	---------	--	----	---------------	---------------

W4-75	16/77/-		15	7321677840748	784074
-------	---------	--	----	---------------	---------------

W4-100	16/102/-		22	7321677840755	784075
--------	----------	--	----	---------------	---------------

W4-150	16/152/-		37	7321677840762	784076
--------	----------	--	----	---------------	---------------

W4-200	16/202/-		55	7321677840779	784077
--------	----------	--	----	---------------	---------------

Steel cable trays

Pre-galvanized - Corrosion class C2

Junctions

Type	Dimensions A/B/C mm		Weight kg/100 pcs	EAN code	Ref. No.
T-junction W12					
T-junction to be used for 90° horizontal junction of cable trays W1/40 and W3/40. Push-in assembly. Material: Sheet steel, pre-galvanized.					
W12/40-50 (flat)	-/185/248		19.6	3606480994975	CSU795383
W12/40-70	38/267/167		49	7321677179084	717908
W12/40-100	38/297/197		64	7321677179091	717909
W12/40-150	38/347/247		92	7321677334858	733485
W12/40-200	38/397/297		128	7321677179107	717910
W12/40-300	38/497/397		212	7321677179114	717911
W12/40-400	38/597/497		314	7321677179121	717912
W12/40-500	38/697/597		438	7321677211869	721186
W12/40-600	38/797/697		580	7321677231980	723198
T-junction to be used for 90° horizontal junction of cable trays W1/60 and W3/60. Push-in assembly. Material: Sheet steel, pre-galvanized.					
W12/60-70	58/267/167		54	7321677820528	782052
W12/60-100	58/297/197		70	7321677820535	782053
W12/60-150	58/347/247		99	7321677820542	782054
W12/60-200	58/397/297		133	7321677820559	782055
W12/60-300	58/497/397		217	7321677820566	782056
W12/60-400	58/597/497		320	7321677820573	782057
W12/60-500	58/697/597		443	7321677820580	782058
W12/60-600	58/797/697		585	7321677820597	782059
W12/60-500 FS	58/697/597		337	7321677824601	782460
W12/60-600 FS	58/797/697		454	7321677824618	782461
X-junction W13					
X-junction to be used for 90° horizontal junction of cable trays W1/40 and W3/40. Push-in assembly. Material: Sheet steel, pre-galvanized.					
W13/40-50 (flat)	-/248/248		23.3	3606480995019	CSU795387
W13/40-70	38/267/267		64	7321677179138	717913
W13/40-100	38/297/297		80	7321677179145	717914
W13/40-200	38/397/397		150	7321677179152	717915
W13/40-300	38/497/497		240	7321677179169	717916
W13/40-400	38/597/597		350	7321677179176	717917
W13/40-500	38/697/697		480	7321677211883	721188
W13/40-600	38/797/797		630	7321677232000	723200
X-junction to be used for 90° horizontal junction of cable trays W1/60 and W3/60. Push-in assembly. Material: Sheet steel, pre-galvanized.					
W13/60-70	58/268/268		62	7321677820955	782095
W13/60-100	58/298/298		78	7321677820962	782096
W13/60-150	58/348/348		110	7321677820979	782097
W13/60-200	58/398/398		146	7321677820986	782098
W13/60-300	58/498/498		234	7321677820993	782099
W13/60-400	58/598/598		342	7321677821006	782100
W13/60-500	58/698/698		469	7321677821013	782101
W13/60-600	58/798/798		616	7321677821020	782102
W13/60-500 FS	58/698/698		328	7321677824625	782462
W13/60-600 FS	58/798/798		441	7321677824632	782463
Cover plate W16					
Cover plate to be used to level out the differences in level between cable tray and junctions, such as 90° bends, T- and X-junctions. To be mounted under the junctions. Material: Sheet steel, pre-galvanized.					
W16-70	1.5/70/70		6	7321677180363	718036
W16-100	1.5/100/100		12	7321677180370	718037
W16-200	1.5/200/200		48	7321677180387	718038
W16-300	1.5/300/300		108	7321677180394	718039
W16-400	1.5/400/400		192	7321677180400	718040

P15354



717910



782055



P15356

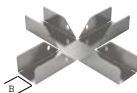

717916



782098



0DA761038



Steel cable trays

Pre-galvanized - Corrosion class C2

Vertical risers

Type	Dimensions A/B/C mm	Weight kg/100 pcs	EAN code	Ref. No.
------	------------------------	----------------------	----------	----------

Vertical riser W11

0DA723228



Vertical riser to be used as internal or external riser for cable tray W1/40 and W3/40. The riser is delivered flat and can be bent to the desired angle up to 90°. Push-in assembly.
Material: Sheet steel, pre-galvanized.

W11/40-50	-/48/150	8	7321677334988	733498
W11/40-70	-/68/150	10	7321677232260	723226
W11/40-100	-/98/150	12	7321677232277	723227
W11/40-150	-/148/150	17	7321677334995	733499
W11/40-200	-/198/200	28	7321677232284	723228
W11/40-300	-/298/200	39	7321677232291	723229
W11/40-400	-/398/200	50	7321677232307	723230
W11/40-500	-/498/200	61	7321677232314	723231
W11/40-600	-/598/200	73	7321677232321	723232

782276



Vertical riser to be used as internal or external riser for cable tray W1/60 and W3/60. The riser is delivered flat and can be bent to the desired angle up to 90°. Push-in assembly.
Material: Sheet steel, pre-galvanized.

W11/60-70	-/67/150	12	7321677822768	782276
W11/60-100	-/97/150	15	7321677822775	782277
W11/60-150	-/147/150	19	7321677822782	782278
W11/60-200	-/197/200	31	7321677822799	782279
W11/60-300	-/297/200	42	7321677822805	782280
W11/60-600	-/397/200	53	7321677822812	782281
W11/60-500	-/497/200	64	7321677822829	782282
W11/60-600	-/597/200	75	7321677822836	782283

Vertical riser W4

784093



Vertical riser suitable for installation tray W4. To be used as internal or external riser. The riser is delivered flat and can be bent to the desired angle up to 90°. Push-in assembly.
Material: Sheet steel, pre-galvanized.

W4-50	16/52/250	15	7321677840892	784089
W4-75	16/77/250	19	7321677840908	784090
W4-100	16/102/250	24	7321677840915	784091
W4-150	16/152/250	33	7321677840922	784092
W4-200	16/202/250	42	7321677840939	784093
W4-250	16/252/250	58	7321677840946	784094
W4-300	16/302/250	68	7321677840953	784095
W4-400	16/402/250	77	7321677840960	784096

Steel cable trays

Pre-galvanized - Corrosion class C2

Reducers

PTCSU-0026



Type	Dimensions A/B/C mm	Weight kg/100 pcs	EAN code	Ref. No.
Reducer W28/40				
Reducer for cable tray W1/W3, system height 40. To be used together with side joint W49 in side transitions. In centered transitions only two reducers W28 are necessary. Material: Sheet steel, pre-galvanized.				
W28/40-50	37.5/50/200	15	7321677935710	793571
W28/40-100	37.5/100/200	17	7321677874361	787436
W28/40-150	37.5/150/200	20	7321677935727	793572
W28/40-200	37.5/200/200	23	7321677874378	787437
W28/40-250	37.5/250/200	26	7321677935734	793573
W28/40-300	37.5/300/200	29	7321677935741	793574
W28/40-350	37.5/350/200	32	7321677935758	793575
W28/40-400	37.5/400/200	36	7321677935765	793576
W28/40-450	37.5/450/200	39	7321677935772	793577
W28/40-500	37.5/500/200	41	7321677935789	793578

787443



Reducer W28/60				
Reducer for cable tray W1/W3, system height 60. To be used together with side joint W49 in side transitions. In centered transitions only two reducers W28 are necessary. Material: Sheet steel, pre-galvanized.				
W28/60-50	57.5/50/200	22	7321677936076	793607
W28/60-100	57.5/100/200	27	7321677874422	787442
W28/60-150	57.5/150/200	31	7321677936083	793608
W28/60-200	57.5/200/200	36	7321677874439	787443
W28/60-250	57.5/250/200	40	7321677936090	793609
W28/60-300	57.5/300/200	45	7321677936106	793610
W28/60-350	57.5/350/200	49	7321677936113	793611
W28/60-400	57.5/400/200	54	7321677936120	793612
W28/60-450	57.5/450/200	58	7321677936137	793613
W28/60-500	57.5/500/200	63	7321677936144	793614

End covers

787732



End cover W45				
End cover to be mounted at the ends of cable trays W1/40 and W3/40 and of lighting trunking W70. Provided with oval holes 6x55 mm on the sides. Push-in assembly. Material: Sheet steel, pre-galvanized.				
W45/40-70	38/100/68	8	7321677317301	731730
W45/40-100	38/100/98	9	7321677317318	731731
W45/40-200	38/100/198	12	7321677317325	731732
W45/40-300	38/100/298	15	7321677317332	731733
W45/40-400	38/100/398	18	3303432388423	731734
W45/40-500	38/100/498	21	7321677317356	731735
W45/40-600	38/100/598	24	7321677317363	731736

PTCSU-0027



End cover to be mounted at the ends of cable trays W1/60 and W3/60. Provided with oval holes 6x55 mm on the sides. Push-in assembly. Material: Sheet steel, pre-galvanized.				
W45/60-70	58/100/68	12	7321677822928	782292
W45/60-100	58/100/98	13	7321677822935	782293
W45/60-200	58/100/198	18	7321677822942	782294
W45/60-300	58/100/298	23	7321677822959	782295
W45/60-600	58/100/398	28	7321677822966	782296
W45/60-500	58/100/498	34	7321677822973	782297
W45/60-600	58/100/598	39	7321677822980	782298

Steel cable trays

Pre-galvanized - Corrosion class C2

Box plates

Type	Dimensions A/B/C mm		Weight kg/100 pcs	EAN code	Ref. No.
Junction box plate W24					
Junction box plate, with or without perforated hole pattern. To be used for the installation of junction boxes, light fittings, etc., in cable trays W1/40 and W3/40 and in lighting trunking W70. Material: Sheet steel, pre-galvanized.					
W24/40	161/43/200		27	7321677179954	717995
W24/40 non-perforated	161/43/200		31	7321677302475	730247
Junction box plate W24					
Junction box plate, with perforated hole pattern. To be used for the installation of junction boxes, light fittings, etc., in cable trays W1/60 and W3/60. Material: Sheet steel, pre-galvanized.					
W24/60	179/43/200		34	7321677181933	718193
Earth clamp W79					
Earth clamp to be used when protective earthing of the junction box plate is required. Material: Steel, electro-galvanized.					
W79	Screw M4/-/4.5		0.2	7321677166404	716640

Outlet and junction box sets

Junction box set					
Junction box set including junction box plate W24/40 and a pre-mounted junction box UP, IP-class IP65. Material: Sheet steel, pre-galvanized.					
Junction box set	161/50/200		39	7321677319633	731963
Box AP9 + Plate W24/40 PG	161/50/200		39	7321677958689	CSU795868
Outlet set					
Outlet set including junction box plate W24/40 and a pre-mounted outlet, 2-way. Material: Sheet steel, pre-galvanized.					
Outlet set	161/53/200		36	7321677342273	734227

Luminaire brackets

Luminaire bracket W25					
Luminaire bracket to be used for assembly of lighting fixtures under Cable trays W1/40 and W3/40 or Lighting trunking W70. Material: Sheet steel, pre-galvanized.					
W25/40-70	62/30/72		7	7321677139118	713911
W25/40-100	62/30/101		8	7321677139125	713912
W25/40-200	62/30/201		11	7321677139149	713914
W25/40-300	62/30/301		19	7321677139163	713916
W25/40-400	62/30/401		23	7321677139170	713917
W25/40-500	62/30/501		27	7321677139187	713918
W25/40-600	62/30/601		31	7321677139132	713913
Luminaire bracket W25					
Luminaire bracket to be used for assembly of lighting fixtures under Cable trays W1/60 and W3/60. Material: Sheet steel, pre-galvanized.					
W25/60-70	82/30/72		7.7	7321677822843	782284
W25/60-100	82/30/101		8.6	7321677822850	782285
W25/60-200	82/30/201		14	7321677822867	782286
W25/60-300	82/30/301		18	7321677822874	782287
W25/60-400	82/30/401		23	7321677822881	782288
W25/60-500	82/30/501		27	7321677822898	782289
W25/60-600	82/30/601		32	7321677822904	782290

Steel cable trays

Pre-galvanized - Corrosion class C2

Luminaire brackets

Type	Dimensions A/B/C mm		Weight kg/100 pcs	EAN code	Ref. No.
Luminaire bracket W50					
Luminaire bracket to be used to mount lighting fixtures between two parallel Cable trays W1/W3 or Lighting trunking W70. Dimension A (* height) is specified when ordering and is depending on the height of the lighting fixture. The weight (***) is calculated for a bracket with a height of 100 mm. Material: Sheet steel, pre-galvanized.					
W50	* /30/250		25**	7321677205202	720520
Luminaire bracket W35					
Luminaire bracket to be used to mount centralized lighting fixtures under Lighting trunking W70. Material: Sheet steel, pre-galvanized.					
W35	15/30/70		3	7321677156504	715650
Luminaire bracket W55					
Luminaire bracket to be used to mount lighting fixtures under Lighting trunking W70. Material: Sheet steel, pre-galvanized.					
W55	16/12/42		8	7321677209798	720979

Integrated ceiling parts

Shade ledge W26					
Shade ledge to be used as a support for ceilings mounted between cable trays with system height 40 mm. Suspended over the lateral side of the cable tray. Also suitable for Lighting trunking W70. Material: Sheet steel, pre-galvanized.					
W26/40	51/41/2000		154	7321677179909	717990
Shade ledge W26/60					
Shade ledge to be used as a support for ceilings mounted between cable trays with system height 60 mm. Suspended over the lateral side of the cable tray. Material: Sheet steel, pre-galvanized.					
W26/60	60/42/2000		185	7321677185597	718559
Ceiling support W27					
Integrated support channel to be used as a support for false ceilings mounted between cable trays with system height 60 mm. Suspended over the lateral side of the cable tray. Material: Sheet steel, pre-galvanized.					
W27/60	60/25/2000		160	7321677185566	718556
Locking clamp W77					
Locking clamp to be used when pendant rail W32 is mounted between two parallel lighting trunking W70 or cable trays W1/W3 for additional stability. Material: Sheet steel, pre-galvanized.					
W77	12/40/47		1.5	7321677167975	716797

Steel cable trays









Pre-galvanized - Corrosion class C2

Screws, bolts and nuts					
	Type	Dimensions A/B/C mm 	Weight kg/100 pcs	EAN code	Ref. No.
P40166	Screw set W34				
	Screw set to be used for mounting of Cable tray W3 onto Cantilever arm 50, Locking clamp W77 and Angle bracket W8 onto Pendant rail W32, Junction box plate W24 onto W3 Cable tray or Lighting trunking W70, as well as for assembly of Angle bracket W8 (light fitting bracket) and for joining of W4 Installation trays. Set including screw MSCS 6x12 and nut M6MF 6. Material: Steel, electro-galvanized.				
	W34	10/10/16	0.8	7321677184736	718473
715646	Screw set W36				
	Screw set including bolt and nut M8 to be used for the mounting of single Pendant attachment W21 or Tube pendant attachment W73 on Support bracket/joint W7. Material: Steel, electro-galvanized.				
	W36	M8	1.2	7321677156467	715646
783500	Screw set W36C				
	Screw set including bolt with slotted screw head and nut M8. To be used for the mounting of single Pendant attachment W21 or Tube pendant attachment W73 on Support bracket/joint W7. Material: Steel, electro-galvanized.				
	W36C	M8	1.8	7321677835003	783500
716799	Screw set W37				
	Screw set including bolt MVB 8x35 and nut M6MF 8, to be used for assembly of Pendant attachment W21 and Ceiling attachment W31 with Pendant rail W32, and for the joining of Pendant rail W32. Material: Steel, electro-galvanized.				
	W37	M8	2.8	7321677167999	716799
0DA735177	Screw set W38P				
	Screw set including screw and nut, to be used for the mounting of joints, bends, junctions, shade ledge W26 and integrated ceiling support channel W27. The patented screw set pierces through painted surfaces securing potential balancing. N.B. The joints must be unpainted. Material: Steel, electro-galvanized.				
	W38P	-	0.4	7321677351770	735177
0DA72868	Screw W40				
	Screw (RXS ST 5,5x13-H) to be used for the locking of T-joint W29 in open junctions. Material: Steel, electro-galvanized.				
	W40	-	0.3	7321677218684	721868
T-bolt single-40	T-bolt 26U				
	T-bolt to be used for mounting with all vertical pieces (except Vertical piece 2) and with Pendant/fixing rail 24/48. Material: Steel, hot-dip-galvanized.				
	26U M8x30	50/44/18	6.8	3606489579777	CSU795595
	26U M10x30	50/44/18	6.8	3606489579715	CSU795589
PTCSU-007	Locking plug W41				
	Locking plug to be used for quick locking of joints, bends and branches in cable trays and lighting trunking. Material: PP+GF10.				
	W41	Ø14/10.5	0.1	7321677186457	718645

Steel cable trays

Pre-galvanized - Corrosion class C2

Threaded rods

Type	Dimensions A/B/C mm		Weight kg/100 pcs	EAN code	Ref. No.
Threaded rod W76					
Threaded rod M6 to be used for light-duty cable tray W1/W3 and lighting trunking W70 suspensions. Material: Steel, electro-galvanized.					
	W76 M6	1000/6/6	18	7321677840618	784061
	W76 M6	2000/6/6	36	7321677929344	792934
	W76 M6	3000/6/6	54	7321677929351	792935
Threaded rod M8 and M10 to be used to suspend cable tray W1/W3 and lighting trunking W70 installations. Material: Steel, electro-galvanized.					
	W76 M8	1000/8/8	32	7321677250790	725079
	W76 M10	2000/10/10	100	7321677167920	716792
	W76 M10	3000/10/10	150	7321677167937	716793
Joint nut M6, M8, M10					
Joint nut to be used to connect two lengths of threaded rods W76. Material: Steel, electro-galvanized.					
	Joint nut M6	30/11.5/10	1.2	7321677840632	784063
	Joint nut M8	40/15/13	5.0	7321677250837	725083
	Joint nut M10	40/18.5/16	7.2	7321677248063	724806
Thread lock B50					
Thread lock M8 and M10 to be used to connect two lengths of threaded rods. Provides a quick and screw-less height adjustment of the threaded rod. Material: Steel, electro-galvanized.					
	B50/M8	10/20/35	1	7332227014564	1149456
	B50/M10	12/24/35	2	7332227014663	1149466
Flange nut M6					
Flange nut to be used to mount support brackets and ceiling brackets onto threaded rods W76. Material: Steel, electro-galvanized.					
	Flange nut M6	M6	0.4	7321677840625	784062
Flange nut B43					
Flange nut to be mounted onto Threaded rod W76 in order to lock it to the Support hook and the Ceiling fittings. Package of 50 pcs. Material: Steel, electro-galvanized.					
	B43/M8	17/17/8	0.4/bag	7321677888474	1149405
	B43/M10	20/20/15	0.56/bag	7332227014649	1149464
Pendant attachment W73					
Tube pendant attachment to be used for mounting of threaded rod W76 M6/M10 in ceiling and cable tray W1/W3 and lighting trunking W70/71. Provides a quick and screw-less height adjustment of the threaded rod. Material: Sheet steel, pre-galvanized.					
	W73 M6	135/26/56	7	7321677912056	791205
	W73 M10	135/26/56	7	7321677166343	716634

Steel cable trays

Pre-galvanized - Corrosion class C2

Ogebe fixings

716474



Type	Dimensions A/B/C mm	Weight kg/100 pcs	EAN code	Ref. No.
Ogebe fixings				
Ogebe fixing type E to be used for mounting in 0.7-0.9 mm sheeting or board material. Examples are hole straps, pendants, ducts, trays and piping. Material: Steel, elctro-galvanized.				
Type E	40/25/48	4.8	7321677164745	716474

Brackets

PTCSU-0037



Support bracket W1940				
Support bracket to be used for invisible installation of cable trays W1/40 and W3/40. Material: Sheet steel, pre-galvanized.				
W1940-100	36/65/90	11	7321677187119	718711
W1940-200	36/65/190	22	7321677344017	734401
W1940-300	36/65/289	50	7321677344024	734402
W1940-400	36/65/389	68	7321677344031	734403
W1940-500	36/65/489	91	7321677823420	782342
W1940-600	36/65/589	110	7321677823437	782343

PTCSU-0037



Support bracket W1960				
Support bracket to be used for invisible installation of cable trays W1/60 and W3/60. Material: Sheet steel, pre-galvanized.				
W1960-100	56/65/89	19	7321677823321	782332
W1960-200	56/65/189	37	7321677823338	782333
W1960-300	56/65/289	58	7321677823345	782334
W1960-400	56/65/389	77	7321677823352	782335
W1960-500	56/65/489	96	7321677823369	782336
W1960-600	56/65/589	115	7321677823376	782337

PTCSU-0044



Support bracket W20				
Support bracket to be used for invisible installation of lighting trunking W70/71, width 70 and 100 mm. The support bracket is snapped firmly into the trunking. Two nuts M10 are included. Suitable for threaded rod W76 M10. Material: Sheet steel, pre-galvanized.				
W20-70	-	9	7321677209736	720973
W20-100	-	13	7321677219438	721943

PTCSU-0038



Support bracket W20A				
Support bracket to be used for invisible installation of lighting trunking W70/71, width 70 and 100 mm. The support bracket is snapped firmly into the trunking. The spring locking device facilitates easy vertical height adjustment. Suitable for threaded rod W76 M10. Material: Sheet steel, pre-galvanized.				
W20A-70	145/75/66	15	7321677209705	720970
W20A-100	148/89/90	20	7321677211807	721180

PTCSU-0049



Steel cable trays

Pre-galvanized - Corrosion class C2

Cantilever arms					
Type	Dimensions A/B/C mm		Weight kg/100 pcs	EAN code	Ref. No.
Cantilever arm 50i					
Cantilever arm to be used for mountings on walls, vertical pieces or pendant/fixing rails. Material: Steel, pre-galvanized.					
50i-100	80/150/43		19	7321677914128	791412
50i-200	85/250/43		29	7321677914135	791413
50i-300	110/350/43		46	7321677914142	791414
50i-400	115/450/44		83	7321677914159	791415
50i/500	130/580/50		160	3606480911354	CSU795322
50i/600	130/680/50		186	3606480911361	CSU795323
Internal cantilever arm W17					
Internal cantilever arm to be used for invisible mounting inside cable tray W1/40 and W3/40. Material: Sheet steel, pre-galvanized.					
W17-100	140/55/119		16	7321677169115	716911
W17-200	140/55/219		35	7321677169122	716912
W17-300	165/75/319		80	7321677169139	716913
W17-400	165/75/419		100	7321677169146	716914
Adjustable internal cantilever arm W1840					
Adjustable internal cantilever arm to be used for invisible mounting inside cable trays W1/40 and W3/40. Adjustability 0-25 mm (W1840-100) and 0-50 mm (W1840-200 to 600). Material: Sheet steel, pre-galvanized.					
W1840-100	160/60/88		36	7321677183609	718360
W1840-200	160/60/188		47	7321677183616	718361
W1840-300	185/60/289		120	7321677835874	783587
W1840-400	185/60/389		139	7321677835881	783588
W1840-500	185/60/489		156	7321677835898	783589
W1840-600	185/60/589		175	7321677835904	783590
Adjustable internal cantilever arm W1860					
Adjustable cantilever arm to be used for invisible mounting inside cable trays W1/60 and W3/60. Adjustability 0-25 mm (W1860-100 length) and 0-50 mm (W1860-200-600). Material: Sheet steel, pre-galvanized.					
W1860-100	160/60/89		47	7321677823925	782392
W1860-200	160/60/189		65	7321677823932	782393
W1860-300	185/60/289		123	7321677823949	782394
W1860-400	185/60/389		142	7321677823956	782395
W1860-500	185/60/489		161	7321677823963	782396
W1860-600	185/60/589		180	7321677823970	782397
Pendant bracket W80					
Pendant bracket W80 mounted under lighting trunking W70-50 and attached with screw set W36/W36C. Threaded rod W76 M6 is easily mounted in the spring clasp without bolts. Adjustable to ± 30 mm. Material: Sheet steel, pre-galvanized.					
W80 M6	160/35/76		5.4	3606480994890	CSU795371
Pendant bracket W81					
Pendant bracket W81 is mounted under lighting trunking W70-50 and is attached with screw set W37. Pendant rail W32 is mounted using screw set W37. Adjustable to ± 18mm. Material: Sheet steel, hot-dip galvanized.					
W81 M6	140/2/76		4.1	3606480994913	CSU795377
Wire bracket W70-50					
Wire bracket for screwless fixation, central suspension of lighting trunking w70-50. Material: Steel, hot-dip galvanized.					
Wire bracket	70/52/58		2.2	3606480994883	CSU795370
Back plate W30					
Back plate to be used for wall installation of internal cantilever arms on porous walls, to reduce the surface pressure. Material: Sheet steel, pre-galvanized.					
W30	135/3/135		42	7321677867929	786792

PTCSU-0005



782393



782393



782393



PTCSU-0039



PTCSU-0039



PTCSU-0039



PTCSU-0039



Steel cable trays

Pre-galvanized - Corrosion class C2

Vertical pieces

Type	Dimensions A/B/C mm		Weight kg/100 pcs	EAN code	Ref. No.
Vertical piece 2Fi					
Vertical piece to be used for lighter mountings with Cantilever arm 50i. Material: Steel, pre-galvanized.					
2Fi-300	272/134/54		97	7321677927234	792723
2Fi-500	497/134/54		137	7321677927241	792724
2Fi-750	722/134/54		177	7321677927258	792725
2Fi-1000	922/134/54		225	7321677927265	792726
Pendant strip W33					
Pendant strip to be used as a light-duty vertical ceiling suspension. The pendant strip is delivered in a straight length of 1 m, to be bent on site. Pendants longer than 1 m are joined by overlapping, using Screw set W36/W36C. Material: Sheet steel, pre-galvanized.					
W33	1000/25/-		19	7321677217861	721786
End bracket WN17					
End bracket to be used as a vertical piece on Support bracket/joint W7 to achieve a concealed suspension. Material: Sheet steel, pre-galvanized.					
WN17	220/23/30		10	7321677330904	733090





Ceiling brackets

Ceiling attachment W31					
Ceiling attachment to be used for installations with Pendant rail W32. Material: Sheet steel, pre-galvanized.					
W31	70/64/25		6.5	7321677168163	716816
Ceiling bracket 5					
Ceiling bracket to be used for installations with Pendant/Fixing rails 24/34 and 24/48. Screw not included. Material: Steel, pre-galvanized.					
5	100/135/40		35	7321677211012	721101
Ceiling bracket 5TPA					
Ceiling bracket with telescopic function, to be used for mounting of various sizes of trapezoid plates. Including screw MVBF 8x16 and nut M6MF8. Breaking load: 150 kg without deformation. Material: Steel, pre-galvanized.					
5TPA	50/76/79-118		14	7321677321773	732177
Ceiling bracket 5TP					
Ceiling bracket to be used in trapezoidal sheeting for installations of Pendant/Fixing rail 24/48. Material: Steel, pre-galvanized.					
5TP	71/35/50		12	7321677253623	725362
Ceiling bracket 2Fi					
Ceiling bracket to be used on Pendant/fixing rail 24/48 to achieve the desired length of vertical pieces. Material: Steel, pre-galvanized.					
2Fi	131/134/54		50	7321677925544	792554

Steel cable trays

Pre-galvanized - Corrosion class C2



Pendant/Fixing rails

	Type	Dimensions A/B/C mm 	Weight kg/100 pcs	EAN code	Ref. No.
 PTCSU-0009	Pendant rail W32				
	Pendant rail to be installed in ceilings in combination with ceiling attachment W31 or Ogebe fixing type E. Material: Sheet steel, pre-galvanized.				
	W32	3000/20/20	180	7321677167982	716798
 P44344	Pendant/Fixing rail 24/34				
	Pendant/Fixing rail to be used for the mounting of support brackets, cantilever arms, etc. Material: Sheet steel, pre-galvanized.				
	24/34	293/16/42	23	7321677253579	725357
	24/34	383/16/42	31	7321677253586	725358
	24/34	495/16/42	40	7321677253593	725359
	24/34	698/16/42	56	7321677253609	725360
	24/34	990/16/42	80	7321677253616	725361
 P44345	Pendant/Fixing rail 24/48				
	Pendant/Fixing rail for mounting of support brackets, cantilever arms, etc. Material: Steel, pre-galvanized.				
	24/48	1000/26/48	175	3606481317858	CSU795564
	24/48	2970/26/48	520	7321677317172	731717
 PTCSU-0010	Pendant attachment W21				
	Pendant attachment to be used in combination with pendant rail W32, support bracket/joint W7, etc. Material: Sheet steel, pre-galvanized.				
	W21	97/50/21	12	7321677166305	716630

Pendant bars

 P44346	Pendant bar 1				
	Pendant bar to be installed in order to reduce the deflection of heavily loaded vertical pieces. Installed with T-bolt and Expansion bolt. Material: Steel, pre-galvanized.				
	1-300	315/161/40	35	7321677927272	792727
	1-500	515/166/40	53	7321677927289	792728
	1-800	815/246/40	82	7321677927296	792729

Angle brackets

 PTCSU-0011	Angle bracket W8				
	Angle bracket to be mounted inside a cable tray W1/W3 for horizontal installation to the wall or vertical installation to the floor. Can also be mounted as a pendant bracket in the lighting trunking W70. Material: Sheet steel, pre-galvanized.				
	W8	80/38/45	6	7321677168217	716821
 PTCSU-0012	Angle bracket W8S				
	Universal angle bracket to be used for various installations of pendant/fixing rail 24/34, support bracket, etc. Material: Sheet steel, pre-galvanized.				
	W8S	120/30/30	8	7321677280711	728071





Pendant joint

 P439860	Pendant joint 2FJ				
	Pendant joint to be used for joining pendant/fixing rails and vertical pieces. Screws M8x16 and nuts included. Material: Steel, pre-galvanized.				
	2FJ	200/18/55	46	3606480911385	CSU795325



Steel cable trays

Pre-galvanized - Corrosion class C2



Lashing wires

		Type	Dimensions A/B/C mm 	Weight kg/100 pcs	EAN code	Ref. No.
Lashing wire						
Lashing wire to be used for lashing of wires on cable ladders. Material: Stainless steel, PVC.						
P140226 		HTR-2303, white PVC	Ø1.25	1.3/100 m	7321677136865	713686
P140225 		HTR-2313, black PVC	Ø1.25	1.3/100 m	7321677136872	713687
Lashing wire to be used for lashing of wires on cable ladders. Material: PVC.						
P140226 		HT-2304, white	Ø1.5	1.8/100 m	7321677136841	713684
P140225 		HT-2314, black	Ø1.5	1.8/100 m	7321677136858	713685

End plugs

End plug 28C and E						
End plug to be mounted on pendant ends to provide protection against personal injury and to make the ends of the profiles more conspicuous. Material: PP/TPE, orange.						
P140067 		28C for Vertical piece 2 and Pendant/fixing rail 24/34	25/19/46	0.5	7321677898756	789875
P140069 		28E for Vertical piece 2F and Pendant/fixing rail 24/48, Pendant Fixing rail 24/48 and CLX ³ Pendant Fixing rail 24/48.	24/30/52	0.5	7321677090211	709021

Accessories

Strip fixing W44						
Strip fixing to be used for easy fixation of cables in an unperforated cable tray W1/40 or W1/60. Material: PPE.						
P148804 		W44	5.5/25/96	1	7321677184699	718469
Protection strip W48						
Protection strip to be used to protect cables from sharp edges when cutting the cable tray W1/W3 or lighting trunking W70. Material: Plastic.						
PTCSU-0003 		W48	10/6/720	6.1	7321677872114	787211
Repair paint						
Anti-corrosive repair paint Galvafruid in a 0.4 l tin for the repair of damages on pre-galvanized or hot-dip galvanized trays and accessories.						
P149450 		Anti-corrosive repair paint	-	104	7321677176373	717637

Reliable, functional and flexible. CLX³ is optimized to deliver for a range of applications.



CLX³ is engineered for all commercial buildings – from modern offices, and state-of-the-art automated distribution centers, to luxurious consumer shopping facilities.

Central Wibe cable tray support



- The CLX³ support system in combination with the Wibe Cable tray is designed to effectively conceal the cables and support brackets, thereby enhancing the aesthetics of the cable routing installation.
- The system is developed to function in synergy with interior design requirements.
- The smooth and rounded design of the bracket helps prevent damage to cables.

Steel cable trays

CLX³ Click suspension - Corrosion class C2

Vertical piece/Fixing rail

PTCSU-181



Type	Dimensions A/B/C mm 	Weight kg/100 pcs	EAN code	Ref. No.
CLX³ pendant 24/48				
Vertical piece/pendant to be used for ceiling suspended mounting. Perforated pattern to be used with CLX ³ cantilever arm or CLX ³ central suspension adapter. Open side can be used with T-bolt. Material: Steel, pre-galvanized.				
CLX ³ pendant-300	295/145/53	90.6	3606489904937	CSU795632
CLX ³ pendant-400	395/145/53	107.5	3606489904944	CSU795633
CLX ³ pendant-500	495/145/53	124.4	3606489904951	CSU795634
CLX ³ pendant-700	695/145/53	158.1	3606489904968	CSU795635
CLX ³ pendant-1000	995/145/53	208.7	3606489904975	CSU795636
CLX ³ pendant-1500	1495/145/53	294.2	3606481828323	CSU795638

PTCSU-466



Type	Dimensions A/B/C mm	Weight kg/100 pcs	EAN code	Ref. No.
CLX³ pendant rail 24/48				
Pendant rail to be used for direct wall mounting or for vertical piece/pendants extensions. To be connected to the vertical piece/pendant together with the pendant joint CSU795325. Perforated pattern to be used with CLX ³ cantilever arm. Open side can be used with T-bolt. Material: Steel, pre-galvanized.				
CLX ³ rail 24/48 300	280/48/26	47.2	3606481828330	CSU795640
CLX ³ rail 24/48 1000	980/48/26	165.1	3606481828347	CSU795641
CLX ³ rail 24/48 3000	2980/48/26	502	3606489904982	CSU795637

Adjustable ceiling plate

PTCSU-187



Type	Dimensions A/B/C mm	Weight kg/100 pcs	EAN code	Ref. No.
CLX³ adjustable ceiling plate				
Adjustable ceiling plate. To be used for angular adjustment of pendant vs ceiling. Adjustment between 0-25°. Adjustable ceiling plate is to be mounted to the CLX ³ pendant. To be assembled with 4 screw set 22S (713694), need to be ordered separately. Tightening force of the screw set minimum torque 20 N.m. Material: Steel, pre-galvanized.				
CLX ³ adjustable ceiling plate	150/100/59	49.8	3606489904999	CSU795639

Central suspensions

PTCSU-465



Type	Dimensions A/B/C mm	Weight kg/100 pcs	EAN code	Ref. No.
CLX³ central suspension bracket, cable tray H40				
Central suspension bracket used for mounting Wibe cable W1/W3/W70 trays height 40 on vertical pieces. Material: Steel, pre-galvanized.				
70	152/37/66	16.5	3606489905088	CSU795653
100	152/37/96	18	3606489905095	CSU795654

PTCSU-467



200 *	36/76/196	26.8	3606489905156	CSU795660
300 *	36/76/296	46	3606489905163	CSU795661
400 *	36/76/396	65.3	3606489905170	CSU795662
500 *	36/76/496	84.6	3606489905187	CSU795663
600 *	36/76/596	103.9	3606489905194	CSU795664

(* the central suspension bracket shall first be assembled together with the CLX³ central suspension adapter (CSU795700) to be able to click in the perforation pattern on the vertical piece.

PTCSU-211





Type	Dimensions A/B/C mm	Weight kg/100 pcs	EAN code	Ref. No.
CLX³ central suspension adapter				
Central suspension adapter to be first clicked to a CLX ³ central suspension bracket of choice. The adaptor fits to all types of CLX ³ central suspension brackets; ladder, tray and mesh. In a second step the adaptor with the central suspension bracket mounted is clicked in the perforation pattern in the rail or the pendant. Material: Steel, pre-galvanized.				
CLX ³ CSB adapter	166/31/39	17.7	3606489905248	CSU795700

Steel cable trays

Pre-galvanized white - Corrosion class C2

Cable trays, unperforated

Type	Dimensions A/B/C mm 	Weight kg/100 m	EAN code	Ref. No.	
Cable tray W1					
Unperforated cable tray for indoor applications in dry environments. System height 40 mm. Provided with holes Ø 5.8 mm at the tray end to be used for fixation of joints. Material: Steel, pre-galvanized, powder-coated white.					
	W1/40-70	40/70/2000	95	7321677289868	728986
		40/70/3000	95	7321677813346	781334
	W1/40-100	40/100/2000	115	7321677289875	728987
		40/100/3000	115	7321677813353	781335
	W1/40-200	40/200/2000	170	7321677289882	728988
		40/200/3000	170	7321677813360	781336
	W1/40-300	40/300/2000	400	7321677289899	728989
		40/300/3000	400	7321677813377	781337
	W1/40-400	40/400/2000	500	7321677289905	728990
		40/400/3000	500	7321677813384	781338
	W1/40-500	40/500/2000	710	7321677289912	728991
		40/500/3000	710	7321677813391	781339
	W1/40-600	40/600/2000	825	7321677289929	728992
		40/600/3000	825	7321677813407	781340
W1/40-500 FS	40/500/2000	715	7321677868339	786833	
W1/40-600 FS	40/600/2000	830	7321677868346	786834	
Unperforated cable tray for indoor applications in dry environments. System height 60 mm. Provided with holes Ø5.8 mm at the tray end to be used for fixation of joints. Material: Steel, pre-galvanized, powder-coated white.					
	W1/60-70	60/70/2000	165	7321677820115	782011
	W1/60-100	60/100/2000	185	7321677820122	782012
	W1/60-200	60/200/2000	335	7321677820139	782013
	W1/60-300	60/300/2000	440	7321677820146	782014
	W1/60-400	60/400/2000	540	7321677820153	782015
	W1/60-500	60/500/2000	755	7321677820160	782016
	W1/60-600	60/600/2000	870	7321677820177	782017
	W1/60-500 FS	60/500/2000	760	7321677820481	782048
	W1/60-600 FS	60/200/2000	875	7321677820498	782049

PTCSU-0002

PTCSU-0002

Steel cable trays

Pre-galvanized white - Corrosion class C2

Cable trays, perforated

PTCSU-0018



Type	Dimensions A/B/C mm	Weight kg/100 m	EAN code	Ref. No.
Cable tray W3				
Perforated cable tray for indoor applications in dry environments. System height 40 mm. Provided with holes Ø 5.8 mm at the tray end to be used for fixation of joints. Oval holes along the lateral side of the tray can be used for mounting of accessories. Material: Steel, pre-galvanized white.				
W3/40-50	40/50/3000	103	7321677375370	737537
W3/40-70	40/70/3000	120	7321677375387	737538
W3/40-100	40/100/3000	136	7321677375394	737539
W3/40-150	40/150/3000	170	7321677375400	737540
W3/40-200	40/200/3000	196	7321677375417	737541
W3/40-300	40/300/3000	316	7321677375424	737542
W3/40-400	40/400/3000	390	7321677375431	737543
W3/40-500	40/500/3000	590	7321677375448	737544
W3/40-600	40/600/3000	683	7321677375455	737545

PTCSU-0018



Perforated cable tray for indoor applications in dry environments. System height 60 mm. Provided with holes Ø 5.8 mm at the tray end to be used for fixation of joints. Oval holes along the lateral side of the tray can be used for mounting of accessories. Material: Sheet steel, pre-galvanized white.				
W3/60-70	60/70/3000	150	7321677823062	782306
W3/60-100	60/100/3000	180	7321677823079	782307
W3/60-150	60/150/3000	200	7321677823086	782308
W3/60-200	60/200/3000	240	7321677823093	782309
W3/60-300	60/300/3000	337	7321677823109	782310
W3/60-400	60/400/3000	440	7321677823116	782311

DDA725592-bis



Installation tray W4				
Perforated installation tray for indoor applications in dry environments. To be used when leading cables down from a cable ladder to machine cabinets, etc. Provided with holes Ø 3.5 mm in the bottom segment of the tray for the clamping of cables with plate screws. Material: Steel, pre-galvanized white.				
W4-50	15/50/1960	57	7321677366330	736633
	15/50/3000	57	7321677872275	787227
W4-75	15/75/1960	76	3303437366341	736634
	15/75/3000	76	7321677872282	787228
W4-100	15/100/1960	93	3303437366358	736635
	15/100/3000	93	7321677872299	787229
W4-150	15/150/1960	125	7321677366361	736636
	15/150/3000	125	7321677872305	787230
W4-200	15/200/1960	195	3303437366372	736637
	15/200/3000	195	7321677872312	787231
W4-250	15/250/1960	228	3303437366389	736638
	15/250/3000	228	7321677872329	787232
W4-300	15/300/1960	238	7321677366392	736639
W4-400	15/400/1960	313	7321677366408	736640

Steel cable trays

Pre-galvanized white - Corrosion class C2

Lighting trunking

Type	Dimensions A/B/C mm 	Weight kg/100 m	EAN code	Ref. No.
Lighting trunking W70-50, -70, -100, -200				
Cable tray with bottom perforation for indoor applications in dry environments. System height 40 mm, length 3000 mm. Oval holes 9x5.8 mm on the lateral sides of the tray end can be used for fixation of joints. The oval hole pattern at the base of the tray can be used for mounting of lighting fixtures. On every 500 mm an oval hole is placed to easily guide fast connectors into the tray. Material: Steel, pre-galvanized white.				
W70-50	40/50/3000	254	3606480756108	CSU795217
W70-70	40/70/3000	274	3606480410390	CSU794184
W70-100	40/100/3000	323	3606480410352	CSU794185
W70-200	40/200/3000	487	3606480410376	CSU794186

P140308



Covers

Weight kg/100 pcs				
Cover W5				
Cover to be used to protect the cables inside the cable tray against damages, dust, liquids, UV-influence, etc. Material: Sheet steel, pre-galvanized white.				
W5-70	10/71/2000	100	7321677290154	729015
W5-100	10/101/2000	140	7321677290161	729016
W5-150	10/151/2000	190	7321677341344	734134
W5-200	10/201/2000	250	7321677290178	729017
W5-300	10/301/2000	360	7321677290185	729018
W5-400	10/401/2000	680	7321677290192	729019
W5-500	10/501/2000	840	7321677290208	729020
W5-600	10/601/2000	700	7321677290215	729021

P140357



Cover clamp W62				
Cover clamp to be used for the fixing of covers on cable trays W1/W3 as well as on lighting trunking W70. Material: Stainless steel 304.				
W62	-/15/10.5	0.8	7321677301867	730186

P140808



Dividers

Dividing strip 39				
Dividing strip to be used to separate power and data communication cables inside a W1/W3 cable tray or W70 lighting trunking. Mounted with Support band 6. Material: Steel, pre-galvanized white.				
39/24	24/24/1750	46	7321677179503	717950
39/55	55/24/1750	73	7321677257867	725786

P140356



Insert piece W39				
Insert piece to be used to join Dividing strips 39/24 in cable tray W1/W3 and lighting trunking W70. The Insert piece can be positioned on Support bracket/joint W7/40 to ensure a continuous separation of cables inside the cable tray. Material: PP, natural coloured.				
W39	37/-/330	3	7321677168248	716824

P140044

Insert piece W39/55				
Insert piece to be used to join Dividing strips 39/55 in Cable trays W1/60 or W3/60. The insert piece can be positioned on Support bracket/joint W7/60 to ensure a continuous separation of cables inside the cable tray. Material: Sheet steel, pre-galvanized white.				
W39/55	54/4.4/400	19	7321677868735	786873

782289



Steel cable trays

Pre-galvanized white - Corrosion class C2

Dividers

Type	Dimensions A/B/C mm	Weight kg/100 pcs	EAN code	Ref. No.
Support band W6				
Support band to be placed inside cable trays to fix the lateral position of one or several Dividing strips W39. The holes in the support band and the locking pins in Dividing strip W39 enable an adjustment of the lateral positioning of the dividing strip with an interval of 25 mm. Material: Sheet steel, pre-galvanized.				
W6-70	-/18/67	1.0	7321677188284	718828
W6-100	-/18/97	1.4	7321677188291	718829
W6-200	-/18/197	2.8	7321677188307	718830
W6-300	-/18/297	4.3	7321677188314	718831
W6-400	-/18/397	5.7	7321677188321	718832
W6-500	-/18/497	7.2	7321677188338	718833
W6-600	-/18/597	8.6	7321677188345	718834

PTCSU-0020



Joints

Type	Dimensions A/B/C mm	Weight kg/100 pcs	EAN code	Ref. No.
Support bracket/joint W7				
To be used as a support bracket or joint for cable tray W1/40, W3/40 and for lighting trunking W70. When joining cable tray W1/40 FS (reinforced), side joint W49/40 must be used. Material: Sheet steel, pre-galvanized white.				
W7/40-70	38/68/200	16	7321677290468	729046
W7/40-100	38/98/200	25	7321677290475	729047
W7/40-200	38/198/200	43	7321677290482	729048
W7/40-300	38/297/300	110	7321677290499	729049
W7/40-400	38/397/300	140	7321677290505	729050
W7/40-500	38/498/300	170	7321677290512	729051
W7/40-600	38/598/300	200	7321677290529	729052
Support bracket/joint W6				
To be used as a support bracket or joint for cable tray W1/60, W3/60. When joining cable tray W1/60 FS (reinforced), side joint W49/60 must be used. Material: Sheet steel, pre-galvanized white.				
W7/60-70	58/68/152	22	7321677823185	782318
W7/60-100	58/98/200	33	7321677823192	782319
W7/60-150	58/148/200	41	7321677823208	782320
W7/60-200	58/198/200	49	7321677823215	782321
W7/60-300	58/297/300	122	7321677823222	782322
W7/60-400	58/397/300	152	7321677823239	782323
W7/60-500	58/498/300	180	7321677823246	782324
W7/60-600	58/598/300	210	7321677823253	782325

PTCSU-0006



40-70, 100, 200, 300, 400

782212



40-500, 600

PTCSU-0006



60-70, 100

782212



60-150

PTCSU-0006



60-200, 300, 400

782212



60-500, 600

PTCSU-0021



Type	Dimensions A/B/C mm	Weight kg/100 pcs	EAN code	Ref. No.
Side joint W49				
Side joint to be used for straight joining of cable trays W1 and W3. Material: Sheet steel, pre-galvanized white.				
W49/40	37.5/-/300	17	7321677868384	786838
W49/60	58/-/300	27	7321677823307	782330

PTCSU-0023



Type	Dimensions A/B/C mm	Weight kg/100 pcs	EAN code	Ref. No.
Joint W2				
Side joint to be used for straight joining of installation tray W4. Material: Sheet steel, pre-galvanized white.				
W2	15/25/200	8	7321677885749	788574

Steel cable trays

Pre-galvanized white - Corrosion class C2

Joins

Type	Dimensions A/B/C mm 	Weight kg/100 pcs	EAN code	Ref. No.
------	--	----------------------	----------	----------

T-joint W9
 T-joint to be used to construct T-sections or X-sections. Also used for oblique branches. The ref. number includes two pieces of T-joints and Screw set W38P.
 Material: Sheet steel, pre-galvanized white.



W9/40	40/72.5/20	6	7321677290949	729094
W9/60	60/72.5/20	5	7321677822188	782218

T-joint W29

T-joint to be used to construct T-junctions or X-junctions. Easy push-in assembly. Locks into the tray via locking flap. To be suspended over the lateral side of the tray and locked in a suitable way.
 Material: Sheet steel, pre-galvanized white.



W29/40-70	38/67/68	8	7321677249428	724942
W29/40-100	38/67/98	12	7321677249435	724943
W29/40-200	38/67/198	21	7321677249442	724944
W29/40-300	38/67/301	30	7321677249459	724945
W29/40-400	38/67/401	40	7321677249466	724946
W29/40-500	38/67/501	50	7321677249473	724947
W29/40-600	38/67/601	59	7321677249480	724948



T-joint to be used to construct T-junctions or X-junctions. Easy push-in assembly. Locks into the tray via locking flap. To be suspended over the lateral side of the tray and locked in a suitable way.
 Material: Sheet steel, pre-galvanized white.

W29/60-70	58/67/68	22	7321677831852	783185
W29/60-100	58/67/98	27	7321677831869	783186
W29/60-200	58/67/198	37	7321677831876	783187
W29/60-300	58/67/298	47	7321677831883	783188
W29/60-400	58/67/398	57	7321677831890	783189
W29/60-500	58/67/498	67	7321677831906	783190
W29/60-600	58/67/598	77	7321677831913	783191

Steel cable trays

Pre-galvanized white - Corrosion class C2

Bends

Type	Dimensions A/B/C mm		Weight kg/100 pcs	EAN code	Ref. No.
90° bend W10					
Horizontal 90° bend to be used for cable trays W1/40 and W3/40. Push-in assembly. Material: Sheet steel, pre-galvanized white.					
<p>P491352 77905</p>	W10/40-50 (flat)	38/183/183	14.9	3606480994944	CSU795380
	W10/40-70	38/167/167	38	7321677292011	729201
	W10/40-100	38/197/197	51	7321677291335	729133
	W10/40-200	38/297/297	108	7321677291342	729134
	W10/40-300	38/397/397	185	7321677291359	729135
	W10/40-400	38/497/497	281	7321677291366	729136
	W10/40-500	38/597/597	400	7321677291373	729137
	W10/40-600	38/697/697	540	7321677291380	729138
Horizontal 90° bend to be used for cable trays W1/60 and W3/60. Push-in assembly. Material: Sheet steel, pre-galvanized white.					
<p>782041</p>	W10/60-70	58/167/167	43	7321677824083	782408
	W10/60-100	58/197/197	55	7321677824090	782409
	W10/60-150	58/247/247	85	7321677824106	782410
	W10/60-200	58/297/297	117	7321677824113	782411
	W10/60-300	58/397/397	196	7321677824120	782412
	W10/60-400	58/497/497	295	7321677824137	782413
	W10/60-500	58/597/597	413	7321677824144	782414
	W10/60-600	58/697/697	551	7321677824151	782415
	W10/60-500 FS	58/597/597	343	7321677871889	787188
	W10/60-600 FS	58/697/697	465	7321677871896	787189
	Adjustable bend W10S				
Adjustable bend to be used for horizontal angling from 105° to 165° in steps of 7.5°. Push-in assembly. Material: Sheet steel, pre-galvanized white.					
<p>PTCSU-0024</p>	W10S/40-70	38/67/67	10	7321677291038	729103
	W10S/40-100	38/97/97	13	7321677291045	729104
	W10S/40-200	38/197/197	40	7321677291052	729105
	W10S/40-300	38/297/297	75	7321677291069	729106
	W10S/40-400	38/397/397	125	7321677291076	729107
	W10S/40-500	38/497/497	270	7321677291083	729108
	W10S/40-600	38/597/597	380	7321677291090	729109
Adjustable bend to be used for horizontal angling from 105° to 165° in steps of 7.5°. Push-in assembly. Material: Sheet steel, pre-galvanized white.					
<p>PTCSU-0025</p>	W10S/60-70	58/67/67	17	7321677824717	782471
	W10S/60-100	58/97/97	23	7321677824724	782472
	W10S/60-150	58/147/147	37	7321677824731	782473
	W10S/60-200	58/197/197	53	7321677824748	782474
	W10S/60-300	58/297/297	97	7321677824755	782475
	W10S/60-400	58/397/397	156	7321677824762	782476
	W10S/60-500	58/497/497	292	7321677824779	782477
	W10S/60-600	58/597/597	406	7321677824786	782478
90° bend W4					
Horizontal 90° bend to be used for cable tray W4. To be mounted on the outside of the tray and attached in the bottom segment with screw set W34. Material: Sheet steel, pre-galvanized white.					
<p>784077</p>	W4-50	16/52/-	10	7321677841134	784113
	W4-75	16/77/-	15	7321677841141	784114
	W4-100	16/102/-	22	7321677841158	784115
	W4-150	16/152/-	37	7321677841165	784116
	W4-200	16/202/-	55	7321677841172	784117
	W4-250	16/252/-	77	7321677841189	784118
	W4-300	16/302/-	102	7321677841196	784119
	W4-400	16/402/-	161	7321677841202	784120

Steel cable trays

Pre-galvanized white - Corrosion class C2

Junctions

Type	Dimensions A/B/C mm		Weight kg/100 pcs	EAN code	Ref. No.
------	------------------------	---	----------------------	----------	----------

T-junction W12

T-junction to be used for 90° horizontal junction of cable trays W1/40 and W3/40. Push-in assembly.
Material: Sheet steel, pre-galvanized white.

W12/40-50 (flat)	-/185/248		21.2	3606480994982	CSU795384
W12/40-70	38/267/167		49	7321677291397	729139
W12/40-100	38/297/197		64	7321677291403	729140
W12/40-200	38/397/297		128	7321677291410	729141
W12/40-300	38/497/397		212	7321677291427	729142
W12/40-400	38/597/497		314	7321677291434	729143
W12/40-500	38/697/597		438	7321677291441	729144
W12/40-600	38/797/697		580	7321677291458	729145

T-junction to be used for 90° horizontal junction of cable trays W1/60 and W3/60. Push-in assembly.
Material: Sheet steel, pre-galvanized white.

W12/60-70	58/267/167		54	7321677824243	782424
W12/60-100	58/297/197		70	7321677824250	782425
W12/60-150	58/347/247		99	7321677824267	782426
W12/60-200	58/397/297		133	7321677824274	782427
W12/60-300	58/497/397		217	7321677824281	782428
W12/60-400	58/597/497		320	7321677824298	782429
W12/60-500	58/697/597		443	7321677824304	782430
W12/60-600	58/797/697		585	7321677824311	782431
W12/60-500 FS	58/697/597		337	7321677871926	787192
W12/60-600 FS	58/797/697		454	7321677871933	787193

X-junction W13

X-junction to be used for 90° horizontal junction of cable trays W1/40 and W3/40. Push-in assembly.
Material: Sheet steel, pre-galvanized white.

W13/40-50 (flat)	-/248/248		24.9	3606480995026	CSU795388
W13/40-70	38/267/267		64	7321677291465	729146
W13/40-100	38/297/297		80	7321677291472	729147
W13/40-200	38/397/397		150	7321677291489	729148
W13/40-300	38/497/497		240	7321677291496	729149
W13/40-400	38/597/597		350	7321677291502	729150
W13/40-500	38/697/697		480	7321677291519	729151
W13/40-600	38/797/797		630	7321677291526	729152

X-junction to be used for 90° horizontal junction of cable trays W1/60 and W3/60. Push-in assembly.
Material: Sheet steel, pre-galvanized white.

W13/60-70	58/268/268		62	7321677824403	782440
W13/60-100	58/298/298		78	7321677824410	782441
W13/60-150	58/348/348		110	7321677824427	782442
W13/60-200	58/398/398		146	7321677824434	782443
W13/60-300	58/498/498		234	7321677824441	782444
W13/60-400	58/598/598		342	7321677824458	782445
W13/60-500	58/698/698		469	7321677824465	782446
W13/60-600	58/798/798		616	7321677824472	782447
W13/60-500 FS	58/698/698		328	7321677871964	787196
W13/60-600 FS	58/798/798		441	7321677871971	787197

Cover plate W16

Cover plate to be used to level out the differences in level between cable tray and junctions, such as 90° bends, T- and X-junctions. To be mounted under the junctions. Material: Sheet steel, pre-galvanized white.

W16-70	1.5/70/70		6	7321677291540	729154
W16-100	1.5/100/100		12	7321677291557	729155
W16-200	1.5/200/200		48	7321677291564	729156
W16-300	1.5/300/300		108	7321677291571	729157
W16-400	1.5/400/400		192	7321677291588	729158

P183554



717910



782055



P183556

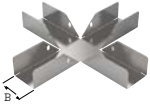

770945



782058



018278038



Steel cable trays

Pre-galvanized white - Corrosion class C2

Vertical riser

Type	Dimensions A/B/C mm		Weight kg/100 pcs	EAN code	Ref. No.
Vertical riser W11					
Vertical riser to be used as internal or external riser for cable tray W1/40 and W3/40. The riser is delivered flat and can be bent to the desired angle up to 90°. Push-in assembly. Material: Sheet steel, pre-galvanized white.					
W11/40-50	-38/48/150		8	7321677341016	734101
W11/40-70	-/68/150		10	7321677291267	729126
W11/40-100	-/98/150		12	7321677291274	729127
W11/40-200	-/198/200		28	7321677291281	729128
W11/40-300	-/298/200		39	7321677291298	729129
W11/40-400	-/398/200		50	7321677291304	729130
W11/40-500	-/498/200		61	7321677291311	729131
W11/40-600	-/598/200		73	7321677291328	729132
Vertical riser W11/60					
Vertical riser to be used as internal or external riser for cable tray W1/60 and W3/60. The riser is delivered flat and can be bent to the desired angle up to 90°. Push-in assembly. Material: Sheet steel, pre-galvanized white.					
W11/60-70	-/67/150		12	7321677825936	782593
W11/60-100	-/97/150		15	7321677825943	782594
W11/60-150	-/147/150		19	7321677825950	782595
W11/60-200	-/197/200		31	7321677825967	782596
W11/60-300	-/297/200		42	7321677825974	782597
W11/60-600	-/397/200		53	7321677825981	782598
W11/60-500	-/497/200		64	7321677825998	782599
W11/60-600	-/597/200		75	7321677826001	782600
Vertical riser W4					
Vertical riser suitable for installation tray W4. To be used as internal or external riser. The riser is delivered flat and can be bent to the desired angle up to 90°. Material: Sheet steel, pre-galvanized white.					
W4-50	16/52/250		15	7321677841059	784105
W4-75	16/77/250		19	7321677841066	784106
W4-100	16/102/250		24	7321677841073	784107
W4-150	16/152/250		33	7321677841080	784108
W4-200	16/202/250		42	7321677841097	784109
W4-250	16/252/250		58	7321677841103	784110
W4-300	16/302/250		68	7321677841110	784111
W4-400	16/402/250		77	7321677841127	784112

0DA73828



782279



784085



Steel cable trays

Pre-galvanized white - Corrosion class C2

Reducers

PTCSU-0026



Type	Dimensions A/B/C mm 	Weight kg/100 pcs	EAN code	Ref. No.
Reducer W28/40				
Reducer for cable tray W1/W3, system height 40. To be used together with side joint W49 in side transitions. In centered transitions only two reducers W28 are necessary. Material: Sheet steel, pre-galvanized white.				
W28/40-50	37.5/50/200	15	7321677935796	793579
W28/40-100	37.5/100/200	17	7321677874385	787438
W28/40-150	37.5/150/200	20	7321677935802	793580
W28/40-200	37.5/200/200	23	7321677874392	787439
W28/40-250	37.5/250/200	26	7321677935819	793581
W28/40-300	37.5/300/200	29	7321677935826	793582
W28/40-350	37.5/350/200	32	7321677935833	793583
W28/40-400	37.5/400/200	36	7321677935840	793584
W28/40-450	37.5/450/200	39	7321677935857	793585
W28/40-500	37.5/500/200	41	7321677935864	793586

787445



Reducer W28/60				
Reducer for cable tray W1/W3, system height 60. To be used together with side joint W49 in side transitions. In centered transitions only two reducers W28 are necessary. Material: Sheet steel, pre-galvanized white.				
W28/60-50	57.5/50/200	22	7321677936151	793615
W28/60-100	57.5/100/200	27	7321677874446	787444
W28/60-150	57.5/150/200	31	7321677936168	793616
W28/60-200	57.5/200/200	36	7321677874453	787445
W28/60-250	57.5/250/200	40	7321677936175	793617
W28/60-300	57.5/300/200	45	7321677936182	793618
W28/60-350	57.5/350/200	49	7321677936199	793619
W28/60-400	57.5/400/200	54	7321677936205	793620
W28/60-450	57.5/450/200	58	7321677936212	793621
W28/60-500	57.5/500/200	63	7321677936229	793622

End covers

729177



End cover W45				
End cover to be mounted at the ends of cable trays W1/40 and W3/40 and of lighting trunking W70. Provided with oval holes 6x55 mm on the sides. Push-in assembly. Material: Sheet steel, pre-galvanized white.				
W45/40-70	38/100/68	8	7321677291779	729177
W45/40-100	38/100/98	9	7321677291786	729178
W45/40-200	38/100/198	12	7321677291793	729179
W45/40-300	38/100/298	15	7321677291809	729180
W45/40-400	38/100/398	18	7321677291816	729181
W45/40-500	38/100/498	21	7321677291823	729182
W45/40-600	38/100/598	24	7321677291830	729183

PTCSU-0027



End cover to be mounted at the ends of cable trays W1/60 and W3/60. Provided with oval holes 6x55 mm on the sides. Push-in assembly. Material: Sheet steel, pre-galvanized white.				
W45/60-70	58/100/68	12	7321677867714	786771
W45/60-100	58/100/98	13	7321677867721	786772
W45/60-200	58/100/198	18	7321677867738	786773
W45/60-300	58/100/298	23	7321677867745	786774
W45/60-600	58/100/398	28	7321677867752	786775
W45/60-500	58/100/498	34	7321677867769	786776
W45/60-600	58/100/598	39	7321677867776	786777

Steel cable trays

Pre-galvanized white - Corrosion class C2

Box plates

Type	Dimensions A/B/C mm		Weight kg/100 pcs	EAN code	Ref. No.
Junction box plate W24					
Junction box plate, with or without perforated hole pattern. To be used for the installation of junction boxes, light fittings, etc. in cable trays W1/40 and W3/40 and in lighting trunking W70. Material: Sheet steel, pre-galvanized white.					
W24/40	161/43/200		27	7321677291847	729184
W24/40 non-perforated	161/43/200		31	7321677342112	734211
Junction box plate W24					
Junction box plate, with perforated hole pattern. To be used for the installation of junction boxes, light fittings, etc., in cable trays W1/60 and W3/60. Material: Sheet steel, pre-galvanized white.					
W24/60	179/43/200		34	7321677826599	782659
Earth clamp W79					
Earth clamp to be used when protective earthing of the junction box plate is required. Material: Steel, electro-galvanized.					
W79	Screw M4/-/4.5		0.2	7321677166404	716640

Outlet and junction box sets







Junction box set					
Junction box set including junction box plate W24/40 and a pre-mounted junction box UP, IP-class IP65. Material: Sheet steel, pre-galvanized.					
Junction box set	161/50/200		39	7321677319640	731964
Outlet set					
Outlet set including junction box plate W24/40 and a pre-mounted outlet, 2-way. Material: Sheet steel, pre-galvanized.					
Outlet set	161/53/200		36	7321677342280	734228

Luminaire brackets

Luminaire bracket W25					
Luminaire bracket to be used for assembly of lighting fixtures under Cable trays W1/40 and W3/40 or Lighting trunking W70. Material: Sheet steel, pre-galvanized white.					
W25/40-70	62/30/72		7	7321677291854	729185
W25/40-100	62/30/101		8	7321677291861	729186
W25/40-200	62/30/201		11	7321677291878	729187
W25/40-300	62/30/301		19	7321677291885	729188
W25/40-400	62/30/401		23	7321677291892	729189
W25/40-500	62/30/501		27	7321677291908	729190
W25/40-600	62/30/601		31	7321677291915	729191
Luminaire bracket W25					
Luminaire bracket to be used for assembly of lighting fixtures under Cable trays W1/60 and W3/60. Material: Sheet steel, pre-galvanized white.					
W25/60-70	82/30/72		7.7	7321677826148	782614
W25/60-100	82/30/101		8.6	7321677826155	782615
W25/60-200	82/30/201		14	7321677826162	782616
W25/60-300	82/30/301		18	7321677826179	782617
W25/60-400	82/30/401		23	7321677826186	782618
W25/60-500	82/30/501		27	7321677826193	782619
W25/60-600	82/30/601		32	7321677826209	782620
Luminaire bracket W50					
Luminaire bracket to be used to mount lighting fittings between two parallel Cable trays W1/W3 or Lighting trunking W70. Dimension A (* height) is specified when ordering and is depending on the height of the lighting fitting. The weight ** is calculated for a bracket with a height of 100 mm. Material: Sheet steel, pre-galvanized white.					
W50	* /30/250		25**	7321677207855	720785
Luminaire bracket W35					
Luminaire bracket to be used to mount centralized lighting fixtures under Lighting trunking W70. Material: Sheet steel, pre-galvanized.					
W35	15/30/70		3	7321677156504	715650









Steel cable trays

Pre-galvanized white - Corrosion class C2

Luminaire brackets					
Type	Dimensions A/B/C mm		Weight kg/100 pcs	EAN code	Ref. No.
Luminaire bracket W55					
Luminaire bracket to be used to mount lighting fixtures under Lighting trunking W70. Material: Sheet steel, pre-galvanized.					
 PTCSU-0041	W55	16/12/42	8	7321677209798	720979
Integrated ceiling parts					
Shade ledge W26					
Shade ledge to be used as a support for ceilings mounted between cable trays with system height 40 mm. Suspended over the lateral side of the cable tray. Also suitable for Lighting trunking W70. Material: Sheet steel, pre-galvanized white.					
 77980	W26/40	51/41/2000	154	7321677291922	729192
Shade ledge W26					
Shade ledge to be used as a support for ceilings mounted between cable trays with system height 60 mm. Suspended over the lateral side of the cable tray. Material: Sheet steel, pre-galvanized white.					
 PTCSU-0034	W26/60	61/42/2000	185	7321677826612	782661
Ceiling support W27					
Integrated support channel to be used as a support for false ceilings mounted between cable trays with system height 40 mm. Suspended over the lateral side of the cable tray. Also suitable for Lighting trunking W70. Material: Sheet steel, pre-galvanized white.					
 PTCSU-0035	W27/40	41/25/2000	130	7321677291939	729193
Ceiling support W27					
Integrated support channel to be used as a support for false ceilings mounted between cable trays with system height 60 mm. Suspended over the lateral side of the cable tray. Material: Sheet steel, pre-galvanized white.					
 PTCSU-0003	W27/60	60/25/2000	160	7321677826629	782662
Locking clamp W77					
Locking clamp to be used when pendant rail W32 is mounted between two parallel lighting trunking W70 or cable trays W1/W3 for additional stability. Material: Sheet steel, pre-galvanized white.					
 PTCSU-0004	W77	12/40/47	1.5	7321677290604	729060









Steel cable trays

Pre-galvanized white - Corrosion class C2

Screws, bolts and nuts					
Type	Dimensions A/B/C mm		Weight kg/100 pcs	EAN code	Ref. No.
Screw set W34					
 P440616	Screw set to be used for mounting of Cable tray W3 onto Cantilever arm 50, Locking clamp W77 and Angle bracket W8 onto Pendant rail W32, Junction box plate W24 onto W3 Cable tray or Lighting trunking W70, as well as for assembly of Angle bracket W8 (light fitting bracket) and for joining of W4 Installation trays. Set including screw MSCS 6x12 and nut M6MF 6. Material: Steel, electro-galvanized.				
	W34	10/10/16	0.8	7321677184736	718473
Screw set W36					
 715646	Screw set including bolt and nut M8 to be used for the mounting of single Pendant attachment W21 or Tube pendant attachment W73 on Support bracket/joint W7. Material: Steel, electro-galvanized.				
	W36	M8	1.2	7321677156467	715646
Screw set W36C					
 783500	Screw set including bolt with slotted screw head and nut M8. To be used for the mounting of single Pendant attachment W21 or Tube pendant attachment W73 on Support bracket/joint W7. Material: Steel, electro-galvanized.				
	W36C	M8	1.8	7321677835003	783500
Screw set W37					
 716799	Screw set including bolt MVBF 8x35 and nut M6MF 8, to be used for assembly of Pendant attachment W21 and Ceiling attachment W31 with Pendant rail W32, and for the joining of Pendant rail W32. Material: Steel, electro-galvanized.				
	W37	M8	2.8	7321677167999	716799
Screw set W38P					
 0DA725777	Screw set including screw (with screw head lacquered white) and nut, to be used for the mounting of joints, bends, junctions, shade ledge W26 and integrated ceiling support channel W27. The patented screw set pierces through painted surfaces securing potential balancing. N.B. The joints must be unpainted. Material: Steel, electro-galvanized, white.				
	W38P	-	0.4	7321677822164	782216
Screw W40					
 0DA721868	Screw (RXS ST 5.5x13-H) to be used for the locking of T-joint W29 in open junctions. Material: Steel, electro-galvanized.				
	W40	-	0.3	7321677218684	721868
T-bolt 26U					
 T-bolt single-40	T-bolt to be used for mounting with all vertical pieces (except Vertical piece 2) and with Pendant/fixing rail 24/48. Material: Steel, hot-dip-galvanized.				
	26U M8x30	50/44/18	6.8	3606489579777	CSU795595
	26U M10x30	50/44/18	6.8	3606489579715	CSU795589
Locking plug W41					
 PFC5U-007	Locking plug to be used for quick locking of joints, bends and branches in cable trays and lighting trunking. Material: PP+GF10.				
	W41	Ø14/10.5	0.1	7321677186457	718645

Steel cable trays

Pre-galvanized white - Corrosion class C2

Threaded rods					
Type	Dimensions A/B/C mm		Weight kg/100 pcs	EAN code	Ref. No.
Threaded rod W76					
Threaded rod M6 to be used for light-duty cable tray W1/W3 and lighting trunking W70 suspensions. Material: Steel, electro-galvanized.					
 6940850000	W76 M6	1000/6/6	18	7321677840618	784061
	W76 M6	2000/6/6	36	7321677929344	792934
	W76 M6	3000/6/6	54	7321677929351	792935
Threaded rod M8 to be used to suspend cable tray W1/W3 and lighting trunking W70 installations. Material: Steel, electro-galvanized.					
 6940850000	W76 M8	1000/8/8	32	7321677250790	725079
	Threaded rod M10 to be used to suspend cable tray W1/W3 and lighting trunking W70 installations. Material: Steel, electro-galvanized white.				
 P14074	W76 M10	2000/10/10	100	7321677290611	729061
	W76 M10	3000/10/10	150	7321677290628	729062
Joint nut M6, M8, M10					
Joint nut to be used to connect two lengths of threaded rods W76. Material: Steel, electro-galvanized.					
 PTCSU-0045	Joint nut M6	30/11.5/10	1.2	7321677840632	784063
	Joint nut M8	40/15/13	5.0	7321677250837	725083
	Joint nut M10	40/18.5/16	7.2	7321677248063	724806
Thread lock B50					
Thread lock M8 and M10 to be used to connect two lengths of threaded rods. Provides a quick and screw-less height adjustment of the threaded rod. Material: Steel, electro-galvanized.					
 P14094	B50/M8	10/20/35	1	7332227014564	1149456
	B50/M10	12/24/35	2	7332227014663	1149466
Flange nut M6					
Flange nut to be used to mount support brackets and ceiling brackets onto threaded rods W76. Material: Steel, electro-galvanized.					
 P14075A	Flange nut M6	M6	0.4	7321677840625	784062
Flange nut B43					
Flange nut to be mounted onto Threaded rod W76 in order to lock it to the Support hook and the Ceiling fittings. Package of 50 pcs. Material: Steel, electro-galvanized.					
 P14075A	B43/M8	17/17/8	0.4/bag	7321677888474	1149405
	B43/M10	20/20/15	0.56/bag	7332227014649	1149464
Pendant attachment W73					
Tube pendant attachment to be used for mounting of threaded rod W76 M6/M10 in ceiling and cable tray W1/W3 and lighting trunking W70/71. Provides a quick and screw-less height adjustment of the threaded rod. Material: Sheet steel, pre-galvanized white.					
 PTCSU-0001	W73 M6	135/26/56	7	7321677912070	791207
	W73 M10	135/26/56	7	7321677290550	729055

Steel cable trays

Pre-galvanized white - Corrosion class C2

Ogebe fixings

716474



Type	Dimensions A/B/C mm	Weight kg/100 pcs	EAN code	Ref. No.
Ogebe fixings				
Ogebe fixing type E to be used for mounting in 0.7-0.9 mm sheeting or board material. Examples are hole straps, pendants, ducts, trays and piping. Material: Steel, elctro-galvanized.				
Type E	40/25/48	4.8	7321677164745	716474

Brackets

PTCSU-0037



Support bracket W1940				
Support bracket to be used for invisible installation of cable trays W1/40 and W3/40. Material: Sheet steel, pre-galvanized white.				
W1940-100	36/65/90	11	7321677290413	729041
W1940-200	36/65/190	22	7321677290420	729042
W1940-300	36/65/289	50	7321677290437	729043
W1940-400	36/65/389	68	7321677290444	729044
W1940-500	36/65/489	91	7321677837533	783753
W1940-600	36/65/589	110	7321677837540	783754

PTCSU-0037



Support bracket W1960				
Support bracket to be used for invisible installation of cable trays W1/60 and W3/60. Material: Sheet steel, pre-galvanized white.				
W1960-100	56/65/89	19	7321677831661	783166
W1960-200	56/65/189	37	7321677831678	783167
W1960-300	56/65/289	58	7321677831685	783168
W1960-400	56/65/389	77	7321677831692	783169
W1960-500	56/65/489	96	7321677831708	783170
W1960-600	56/65/589	115	7321677831715	783171

PTCSU-0049



Support bracket W20A				
Support bracket to be used for invisible installation of lighting trunking W70/71, width 70 and 100 mm. The support bracket is snapped firmly into the trunking. The spring locking device facilitates easy vertical height adjustment. Suitable for threaded rod W76 M10. Material: Sheet steel, pre-galvanized white.				
W20A-70	145/75/66	15	7321677290277	729027
W20A-100	148/89/90	20	7321677290284	729028

Steel cable trays

Pre-galvanized white - Corrosion class C2

Cantilever arms					
Type	Dimensions A/B/C mm		Weight kg/100 pcs	EAN code	Ref. No.
Cantilever arm 50i					
Cantilever arm 50i to be used for lighter mountings on walls, vertical pieces or pendant/fixing rails. Material: Steel, pre-galvanized white.					
50i-100	80/43/150		19	7321677914166	791416
50i-200	85/43/250		29	7321677914173	791417
50i-300	110/43/350		46	7321677914180	791418
50i-400	115/44/450		83	7321677914197	791419
Internal cantilever arm W17/40					
Internal cantilever arm to be used for invisible mounting inside cable tray W1/40 and W3/40. Material: Sheet steel, pre-galvanized white.					
W17/40-100	140/55/119		16	7321677290291	729029
W17/40-200	140/55/219		35	7321677290307	729030
W17/40-300	165/75/319		80	7321677290314	729031
W17/40-400	165/75/419		100	7321677290321	729032
Adjustable internal cantilever arm W1840					
Adjustable internal cantilever arm to be used for invisible mounting inside cable trays W1/40 and W3/40. Adjustability 0-25 mm (W1840-100) and 0-50 mm (W1840-200-600). Material: Sheet steel, pre-galvanized white.					
W1840-100	160/60/88		36	7321677290338	729033
W1840-200	160/60/188		47	7321677290345	729034
W1840-300	185/60/289		120	7321677835911	783591
W1840-400	185/60/389		139	7321677835928	783592
W1840-500	185/60/489		156	7321677835935	783593
W1840-600	185/60/589		175	7321677835942	783594
Adjustable internal cantilever arm W1860					
Adjustable cantilever arm to be used for invisible mounting inside cable trays W1/60 and W3/60. Adjustability 0-25 mm (100 mm length) and 0-50 mm (other lengths). Material: Sheet steel, pre-galvanized white.					
W1860-100	160/60/89		47	7321677835041	783504
W1860-200	160/60/189		65	7321677835058	783505
W1860-300	185/60/289		123	7321677835065	783506
W1860-400	185/60/389		142	7321677835072	783507
W1860-500	185/60/489		161	7321677835089	783508
W1860-600	185/60/589		180	7321677835096	783509
Pendant bracket 80					
Pendant bracket W80 mounted under lighting trunking W70-50 and attached with screw set W36/W36C. Threaded rod W76 M6 is easily mounted in the spring clasp without bolts. Adjustable to ± 30 mm. Material: Sheet sheet steel, pre-galvanized white.					
W80 M6	160/35/76		5.4	3606480994906	CSU795372
Pendant bracket W81					
Pendant bracket W81 is mounted under lighting trunking W70-50 and is attached with screw set W37. Pendant rail W32 is mounted mounted using screw set W37. Adjustable to ± 18 mm. Material: Sheet steel, Zinkpox coated white.					
W81 M6	140/2/76		4.1	3606480994920	CSU795378
Wire Bracket W70-50					
Wire bracket for screwless fixation, central suspension of lighting trunking W70-50. Material: Steel, hot-dip galvanized.					
Wire bracket	70/52/58		2.2	3606480994883	CSU795370
Back plate W30					
Back plate to be used for wall installation of internal cantilever arms on porous walls, to reduce the surface pressure. Material: Sheet steel, pre-galvanized white.					
W30	135/3/135		42	7321677867936	786793

P138932



PTCSU-0005



782383



782383



P163850



P163851



P16349



PTCSU-0039



Steel cable trays

Pre-galvanized white - Corrosion class C2

Vertical pieces

Type	Dimensions A/B/C mm		Weight kg/100 pcs	EAN code	Ref. No.
Pendant strip W33					
Pendant strip to be used as a light-duty vertical ceiling suspension. The pendant strip is delivered in a straight length of 1 m, to be bent on site. Pendants longer than 1 m are joined by overlapping, using Screw set W36/W36C. Material: Sheet steel, pre-galvanized white.					
W33	1000/25/-		19	7321677290598	729059

72786



Ceiling brackets

Ceiling attachment W31					
Ceiling attachment to be used for installations with Pendant rail W32. Material: Sheet steel, pre-galvanized white.					
W31	70/64/25		6.5	7321677290635	729063
Ceiling bracket 5TPA					
Ceiling bracket with telescopic function, to be used for mounting of various sizes of trapezoid plates. Including screw MVBF 8x16 and nut M6MF8. Breaking load: 150 kg without deformation. Material: Steel, pre-galvanized white.					
5TPA	50/76/79-118		14	7321677334865	733486

718896



P440349



Pendant rails

Pendant rail W32					
Pendant rail to be installed in ceilings in combination with ceiling attachment W31 or Ogebe fixing type E. Material: Sheet steel, pre-galvanized white.					
W32	3000/20/20		180	7321677290581	729058
Pendant attachment W21					
Pendant attachment to be used in combination with pendant rail W32, support bracket/joint W7, etc. Material: Sheet steel, pre-galvanized white.					
W21	97/50/21		12	7321677290543	729054

PTCSU-0008



PTCSU-0070



Angle brackets

Angle bracket W8					
Angle bracket to be mounted inside a cable tray W1/W3 for horizontal installation to the wall or vertical installation to the floor. Can also be mounted as a pendant bracket in the lighting trunking W70. Material: Sheet steel, pre-galvanized white.					
W8	80/38/45		6	7321677290666	729066
Angle bracket W8S					
Universal angle bracket to be used for various installations of pendant/fixing rail 24/34, support bracket, etc. Material: Sheet steel, pre-galvanized white.					
W8S	120/30/30		8	7321677268740	726874

PTCSU-0011



PTCSU-0072



Accessories

Strip fixing W44					
Strip fixing to be used for easy fixation of cables in an unperforated cable tray W1/40 or W1/60. Material: PPE.					
W44	5.5/25/96		1	7321677184699	718469
Protection strip W48					
Protection strip to be used to protect cables from sharp edges when cutting the cable tray W1/W3 or lighting trunking W70. Material: Plastic.					
W48	10/6/720		6.1	7321677872114	787211
Repair paint					
Repair paint for the repair of minor damages of powder-coated products. Colour white RAL 9003, gloss 30. Spray bottle, 0.4 l.					
Repair paint, white	-		60	7321677397136	739713

P448504



PTCSU-0073



P448450



Steel cable trays

Hot-dip galvanized - Corrosion class C3, C4

Cable trays, perforated

Type	Dimensions A/B/C mm		Weight kg/100 m	EAN code	Ref. No.
Cable tray W3					
Perforated cable tray for indoor or outdoor industrial applications. System height 40 mm. Provided with holes Ø 5.8 mm at the tray end to be used for fixation of joints. Oval holes along the lateral sides of the tray can be used for mounting of accessories. Material: Steel, hot-dip galvanized.					
W3/40-50	40/50/3000		110	7321677354009	735400
W3/40-70	40/70/3000		120	7321677354016	735401
W3/40-100	40/100/3000		156	7321677354023	735402
W3/40-150	40/150/3000		170	7321677354030	735403
W3/40-200	40/200/3000		220	7321677354047	735404
W3/40-300	40/300/3000		350	7321677354054	735405
W3/40-400	40/400/3000		453	7321677354061	735406
W3/40-500	40/500/3000		620	7321677354078	735407
W3/40-600	40/600/3000		723	7321677354085	735408

PTCSU-0018



Type	Dimensions A/B/C mm	Weight kg/100 m	EAN code	Ref. No.
Installation tray W4				
Perforated installation tray for indoor or outdoor industrial applications. To be used when leading cables down from a cable ladder to machine cabinets, etc. Provided with holes Ø 3.5 mm in the bottom segment of the tray for the clamping of cables with plate screws. Material: Steel, hot-dip galvanized.				
W4-50	15/50/1960	57	7321677366132	736613
	15/50/3000	57	7321677359776	735977
W4-75	15/75/1960	76	7321677366149	736614
	15/75/3000	76	7321677359783	735978
W4-100	15/100/1960	93	7321677366156	736615
	15/100/3000	93	7321677359790	735979
W4-150	15/150/1960	125	7321677366163	736616
	15/150/3000	125	7321677359806	735980
W4-200	15/200/1960	195	7321677366170	736617
	15/200/3000	195	7321677359813	735981
W4-250	15/250/1960	228	7321677366187	736618
	15/250/3000	228	7321677359820	735982
W4-300	15/300/1960	238	7321677366194	736619
W4-400	15/400/1960	313	7321677366200	736620

ODAY759R2-bis



Lighting trunking

Type	Dimensions A/B/C mm	Weight kg/100 pcs	EAN code	Ref. No.
Lighting trunking W70-50, -70, -100				
Cable tray with bottom perforation for indoor applications in dry environments. System height 40 mm, length 3000 mm. Oval holes 9x5.8 mm on the lateral sides of the tray end can be used for fixation of joints. The oval hole pattern at the base of the tray can be used for mounting of lighting fixtures. On every 500 mm an oval hole is placed to easily guide fast connectors into the tray. Material: Steel, hot-dip galvanized.				
W70-50	40/50/3000	271	3606480756115	CSU795218
W70-70	40/70/3000	293	3606480464812	CSU794528
W70-100	40/100/3000	346	3606480464829	CSU794529

PTCSU-0019



Covers

Type	Dimensions A/B/C mm	Weight kg/100 pcs	EAN code	Ref. No.
Cover W5				
Cover to be used to protect the cables inside the cable tray against damages, dust, liquids, UV-influence, etc. Material: Sheet steel, hot-dip galvanized.				
W5-70	10/71/2000	160	7321677322626	732262
W5-100	10/101/2000	210	7321677322633	732263
W5-150	10/151/2000	290	7321677322640	732264
W5-200	10/201/2000	370	7321677322657	732265
W5-300	10/301/2000	540	3606480535734	732266
W5-400	10/401/2000	710	7321677322671	732267
W5-500	10/501/2000	880	7321677322688	732268
W5-600	10/601/2000	1050	7321677322695	732269
Cover clamp W62				
Cover clamp to be used for the fixing of covers on cable trays W3 as well as on lighting trunking W70. Material: Stainless steel 304.				
W62	-/15/10.5	0.8	7321677301867	730186

PK40357





PK48008









Steel cable trays

Hot-dip galvanized - Corrosion class C3, C4

Dividers

Type	Dimensions A/B/C mm		Weight kg/100 pcs	EAN code	Ref. No.
Dividing strip W39					
Dividing strip to be used to separate power and data communication cables inside a W3 cable tray or W70 lighting trunking. Material: Steel, hot-dip galvanized.					
 P140356	39/24	24/24/1750	46	7321677317479	731747
	39/55	55/24/1750	73	7321677329830	732983
Insert piece W39					
Insert piece to be used to join Dividing strips 39/24 in cable tray W3 and lighting trunking W70. The Insert piece can be positioned on Support bracket/joint W7/40 to ensure a continuous separation of cables inside the cable tray. Material: Plastic, natural coloured.					
 P140044	W39	37/-/330	3	7321677168248	716824

Joints

Joint W7/40					
To be used as a joint for cable tray W3/40 and for lighting trunking W70. Material: Sheet steel, hot-dip galvanized.					
 40-50, 40-70, 100, 40-150, 40-200 782212	W7/40-50	38/46/200	18	7321677912735	791273
	W7/40-70	38/66/200	21	7321677912742	791274
	W7/40-100	38/96/200	26	7321677912759	791275
	W7/40-150	38/146/200	34	7321677912766	791276
	W7/40-200	38/196/200	42	7321677912773	791277
	W7/40-300	38/296/300	107	7321677912780	791278
 40-300, 40-400 PTCSU-0006	W7/40-400	38/396/300	137	7321677912797	791279
	W7/40-500	38/496/300	166	7321677912803	791280
 40-500, 40-600 782212	W7/40-600	38/596/300	195	7321677912810	791281
	Side joint W49				
Side joint to be used for straight joining of cable tray W3/40. Material: Sheet steel, hot-dip galvanized.					
 PTCSU-0021	W49/40	37.5/-/300	17	7321677301911	730191
Flexible coupler W3-40					
Side joint to be used for straight joining of cable tray W3/40 and can also be used to create T-junctions, X-junctions, reducers (left, right and straight), horizontal bends, vertical risers and direct mounting suspension strips. Material: Sheet steel, zinc+ treatment					
 PTCSU-0022	W3/40	36/2/300	17	3606480788987	CSU795136
Joint W2					
Side joint to be used for straight joining of installation tray W4. Material: Sheet steel, hot-dip galvanized.					
 PTCSU-0023	W2	15/25/200	8	7321677885732	788573

Steel cable trays

Hot-dip galvanized - Corrosion class C3, C4

Bends					
Type	Dimensions A/B/C mm		Weight kg/100 pcs	EAN code	Ref. No.
T-joint W9					
T-joint to be used to construct T-sections or X-sections. Also used for oblique branches. The ref. number includes two pieces of T-joints and Screw set W38P. Material: Sheet steel, hot-dip galvanized.					
W9/40	40/72.5/20		6	7321677346226	734622
90° bend W10F					
Horizontal 90° bend to be used for cable trays W3/40. Push-in assembly. Material: Sheet steel, hot-dip galvanized.					
W10/40-50 (flat)	38/183/183		14.9	3606480994951	CSU795381
W10F/40-50	38/47/119		14	7321677836604	783660
W10F/40-70	38/67/153		23	7321677836611	783661
W10F/40-100	38/97/204		39	7321677836628	783662
W10F/40-150	38/147/290		74	7321677836635	783663
W10F/40-200	38/197/375		119	7321677836642	783664
W10F/40-300	38/297/480		242	7321677836659	783665
W10F/40-400	38/397/580		353	7321677836666	783666
W10F/40-500	38/497/714		528	7321677836673	783667
W10F/40-600	38/597/814		685	7321677836680	783668
Adjustable bend W10S					
Adjustable bend to be used for horizontal angling from 105° to 165° in steps of 7.5°. Push-in assembly. Material: Sheet steel, hot-dip galvanized.					
W10S/40-50	38/47/47		9	7321677345915	734591
W10S/40-70	38/67/67		10	7321677345922	734592
W10S/40-100	38/97/97		13	7321677345939	734593
W10S/40-150	38/147/147		24	7321677345946	734594
W10S/40-200	38/197/197		40	7321677345953	734595
W10S/40-300	38/297/297		94	7321677345960	734596
W10S/40-400	38/397/397		156	7321677345977	734597
W10S/40-500	38/497/497		270	7321677345984	734598
W10S/40-600	38/597/597		380	7321677345991	734599
90° bend W4					
Horizontal 90° bend to be used for cable tray W4. To be mounted on the outside of the tray and attached in the bottom segment with screw set W38P. Material: Sheet steel, hot-dip galvanized.					
W4-50	16/52/-		10	7321677840816	784081
W4-75	16/77/-		15	7321677840823	784082
W4-100	16/102/-		22	7321677840830	784083
W4-150	16/152/-		37	7321677840847	784084
W4-200	16/202/-		55	7321677840854	784085
W4-250	16/252/-		77	7321677840861	784086
W4-300	16/302/-		102	7321677840878	784087
W4-400	16/402/-		161	7321677840885	784088
T-junction W12F					
T-junction to be used for 90° horizontal junction of cable trays W3/40. Push-in assembly. Material: Sheet steel, hot-dip galvanized.					
W12/40-50 (flat)	-/185/248		21.6	3606480994999	CSU795385
W12F/40-50	38/47/171		21	7321677836703	783670
W12F/40-70	38/67/219		29	7321677836710	783671
W12F/40-100	38/97/312		49	7321677836727	783672
W12F/40-150	38/147/432		89	7321677836734	783673
W12F/40-200	38/197/553		154	7321677836741	783674
W12F/40-300	38/297/662		300	7321677836758	783675
W12F/40-400	38/397/762		428	7321677836765	783676
W12F/40-500	38/497/932		640	7321677836772	783677
W12F/40-600	38/597/1032		817	7321677836789	783678

Steel cable trays

Hot-dip galvanized - Corrosion class C3, C4

Junctions

Type	Dimensions A/B/C mm		Weight kg/100 pcs	EAN code	Ref. No.
X-junction W13F					
X-junction to be used for 90° horizontal junction of cable trays W3/40. Push-in assembly. Material: Sheet steel, hot-dip galvanized.					
W13/40-50 (flat)	-/248/248		26.5	3606480995033	CSU795389
W13F/40-50	38/47/148		21	7321677836802	783680
W13F/40-70	38/67/217		34	7321677836819	783681
W13F/40-100	38/97/313		59	7321677836826	783682
W13F/40-150	38/147/434		117	7321677836833	783683
W13F/40-200	38/197/555		194	7321677836840	783684
W13F/40-300	38/297/662		370	7321677836857	783685
W13F/40-400	38/397/762		510	7321677836864	783686
W13F/40-500	38/497/932		766	7321677836871	783687
W13F/40-600	38/597/1032		966	7321677836888	783688

P163556

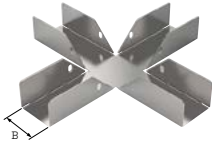

P17CSU-0070



Vertical risers

Vertical riser W11					
Vertical riser to be used as internal or external riser for cable trays W3/40. The riser is delivered flat and can be bent to the desired angle up to 90°. Push-in assembly. Material: Sheet steel, hot-dip galvanized.					
W11/40-50	-/48/150		8	7321677341016	734101
W11/40-70	-/68/150		10	7321677341023	734102
W11/40-100	-/98/150		12	7321677341030	734103
W11/40-150	-/148/150		17	7321677341047	734104
W11/40-200	-/198/200		28	7321677341054	734105
W11/40-300	-/298/200		39	7321677341061	734106
W11/40-400	-/398/200		50	7321677341078	734107
W11/40-500	-/498/200		61	7321677341085	734108
W11/40-600	-/598/200		73	7321677341092	734109
Vertical riser W11F					
W11F40-50	-/48/300		26	7321677839087	783908
W11F40-70	-/68/300		31	7321677839094	783909
W11F40-100	-/98/300		40	7321677839100	783910
W11F40-150	-/148/300		51	7321677839117	783911
W11F40-200	-/198/300		66	7321677839124	783912
W11F40-300	-/298/300		109	7321677839131	783913
W11F40-400	-/398/300		140	7321677839148	783914
W11F40-500	-/498/300		164	7321677839155	783915
W11F40-600	-/598/300		195	7321677839162	783916
Vertical riser W4					
Vertical riser suitable for installation tray W4. To be used as internal or external riser. The riser is delivered flat and can be bent to the desired angle up to 90°. Push-in assembly. Material: Sheet steel, hot-dip galvanized.					
W4-50	16/52/250		15	7321677840977	784097
W4-75	16/77/250		19	7321677840984	784098
W4-100	16/102/250		24	7321677840991	784099
W4-150	16/152/250		33	7321677841004	784100
W4-200	16/202/250		42	7321677841011	784101
W4-250	16/252/250		58	7321677841028	784102
W4-300	16/302/250		68	7321677841035	784103
W4-400	16/402/250		77	7321677841042	784104

03A723228



P17CSU-0088



784093



Steel cable trays

Hot-dip galvanized - Corrosion class C3, C4

Reducers

PTCSU-0028



Type	Dimensions A/B/C mm 	Weight kg/100 pcs	EAN code	Ref. No.
Reducer W28/40				
Reducer for cable tray W3, system height 40. To be used together with side joint W49 in side transitions. In centered transitions only two reducers W28 are necessary. Material: Sheet steel, hot-dip galvanized.				
W28/40-50	37.5/50/200	15	7321677935871	793587
W28/40-100	37.5/100/200	17	7321677935888	793588
W28/40-150	37.5/150/200	20	7321677935895	793589
W28/40-200	37.5/200/200	23	7321677935901	793590
W28/40-250	37.5/250/200	26	7321677935918	793591
W28/40-300	37.5/300/200	29	7321677935925	793592
W28/40-350	37.5/350/200	32	7321677935932	793593
W28/40-400	37.5/400/200	36	7321677935949	793594
W28/40-450	37.5/450/200	39	7321677935956	793595
W28/40-500	37.5/500/200	41	7321677935963	793596

End covers

73732



PTCSU-0088



73732



Type	Dimensions A/B/C mm	Weight kg/100 pcs	EAN code	Ref. No.
End cover W45				
End cover to be mounted at the ends of cable trays W3/40 and of lighting trunking W70. Provided with oval holes 6x55 mm on the sides. Push-in assembly. Material: Sheet steel, hot-dip galvanized.				
W45/40-70	38/100/68	8	7321677830305	783030
W45/40-100	38/100/98	9	7321677830312	783031
W45/40-150	38/100/148	10	7321677830329	783032
W45/40-200	38/100/198	12	7321677830336	783033
W45/40-300	38/100/298	15	7321677830343	783034
W45/40-400	38/100/398	18	7321677830350	783035
W45/40-500	38/100/498	21	7321677830367	783036
W45/40-600	38/100/598	24	7321677830374	783037

Box plates

PTCSU-0028



Type	Dimensions A/B/C mm	Weight kg/100 pcs	EAN code	Ref. No.
Junction box plate W24				
Junction box plate, with perforated hole pattern. To be used for the installation of junction boxes, light fittings, etc., in cable trays W3/40 and in lighting trunking W70. Material: Sheet steel, hot-dip galvanized.				
W24/40	161/43/200	27	7321677346172	734617
Box U56 w/o T+Plate W24/40	161/50/200	39	7321677958672	CSU795867
Box AP9 + Plate W24/40	161/50/200	39	7321677958696	CSU795869
Outlet2-W IP44+Plate W24/40	164/64/170	40	7321677958719	CSU795871

Screws, bolts and nuts

P44051



Type	Dimensions A/B/C mm	Weight kg/100 pcs	EAN code	Ref. No.
Screw set 22S				
Screw set to be used for installation of Ceiling bracket 5 on Pendant/fixing rails 24/34 and 24/48, Angle bracket 5L against the back of Pendant/fixing rails, Pendant/fixing rails back to back. Set including screw MVBF 8x16 and nut M6MF8. Material: Steel, hot-dip galvanized.				
22S	-	1.9	7321677136940	713694

P44056



Type	Dimensions A/B/C mm	Weight kg/100 pcs	EAN code	Ref. No.
Screw set W34				
Screw set to be used for mounting of Cable tray W3 onto Cantilever arm 50 and Angle bracket W8 onto Pendant rail W32, Junction box plate W24 onto W3 Cable tray or Lighting trunking W70, as well as for assembly of Angle bracket W8 (light fitting bracket) and for joining of W4 Installation trays. Set including screw MSCS 6x12 and nut M6MF6. Material: Steel, Dacromet.				
W34	10/10/16	0.8	7321677346462	734646

00A735177



Type	Dimensions A/B/C mm	Weight kg/100 pcs	EAN code	Ref. No.
Screw set W38P C4				
Screw set including screw and nut, to be used for the mounting of joints, bends, junctions, shade ledge W26 and integrated ceiling support channel W27. The patented screw set pierces through painted surfaces securing potential balancing. N.B. The joints must be unpainted. Material: Steel, electro-galvanized.				
Screw set W38P C4	-	0.4	7321677351770	735177

Steel cable trays

Hot-dip galvanized - Corrosion class C3, C4

Screws, bolts and nuts

Type	Dimensions A/B/C mm	Weight kg/100 pcs	EAN code	Ref. No.	
T-bolt 26U					
T-bolt to be used for mounting with all vertical pieces (except Vertical piece 2) and with Pendant/fixing rail 24/48. Material: Steel, hot-dip galvanized.					
	26U M8x30	50/44/18	6.8	3606489579777	CSU795595
	26U M10x30	50/44/18	6.8	3606489579715	CSU795589
	26U M10x40	60/44/18	8.2	3606489579722	CSU795590
	26U M10x50	70/44/18	9.5	3606489579739	CSU795591
Spring nut M8					
Spring nut to be used for fastening of accessories (control panels, etc.) on Pendant/fixing rail 24/48. Material: Steel, hot-dip galvanized.					
	M8	-	2.7	7321677164073	716407
Locking plug W41					
Locking plug to be used for quick locking of joints, bends and branches in cable trays and lighting trunking. Material: PP+GF10.					
	W41	Ø14/10.5	0.1	7321677186457	718645

Threaded rods

Threaded rod W76					
Threaded rod for M8 ceiling mounting of cable support. For fixing, use Flange Nut M8 and for extension, Distance nut M8. Material: Steel, hot-dip galvanized.					
	W76/M8	8/8/1000	32	3606480483783	CSU794697
		8/8/2000	64	3606480483776	CSU734698
Flange nut					
Flange Nut M8 to be mounted on Threaded rod W76. Intended for ceiling mounting of cable support. Material: Steel, hot-dip galvanized.					
	Flange nut M8	17/17/8	1	3606480483806	CSU794715
Distance nut					
Distance nut M8 to be used as an extension and a coupler of Threaded rod W76. Intended for ceiling mounting of cable support. Material: Steel, hot-dip galvanized.					
	Distance nut M8	15/15/30	4	3606480483790	CSU794699
Nut M8, M10					
Nut to be used for the mounting of Threaded rod W76 M8 and M10 respectively. Material: Steel, hot-dip galvanized.					
	Nut M8	-	0.54	7321677250851	725085
	Nut M10	-	1.1	7321677239382	723938
Mounting set W78					
Mounting set including washer Ø50 and nut M10, to be used for mounting of threaded rod W76 in plate material or light concrete ceilings. Material: Steel, hot-dip galvanized.					
	W78	Ø50/M10	5.5	7321677170692	717069

Brackets

Support bracket W1940					
Support bracket to be used for invisible installation of cable trays W3/40. Material: Sheet steel, hot-dip galvanized.					
	W1940-100	36/65/90	11	7321677344529	734452
	W1940-200	36/65/190	22	7321677344536	734453
	W1940-300	36/65/289	50	7321677344543	734454
	W1940-400	36/65/389	68	7321677344550	734455
	W1940-500	36/65/489	91	7321677344567	734456
	W1940-600	36/65/589	110	7321677344574	734457

Steel cable trays

Hot-dip galvanized - Corrosion class C3, C4

Cantilever arms

Type	Dimensions A/B/C mm 	Weight kg/100 pcs	EAN code	Ref. No.
------	--	----------------------	----------	----------

Cantilever arm 50i

Cantilever arm to be used for lighter mountings on walls, vertical pieces or pendant/fixing rails. Dimensions 500 and 600 marked with * will be available in middle of July 2016. Material: Steel, hot dip galvanized..



50i/100	120/180/40	42	3606480911293	CSU795316
50i/200	120/280/40	55	3606480911309	CSU795317
50i/300	120/380/40	68	3606480911316	CSU795318
50i/400	142/480/40	86	3606480911323	CSU795319
50i/500 *	130/580/50	160	3606480911330	CSU795320
50i/600 *	130/680/50	186	3606480911347	CSU795321

Cantilever arm 50

Cantilever arm for mounting on walls, pendant/fixing rails or vertical pieces. Material: Steel, hot-dip galvanized.



50-100	85/40/150	24	7321677234325	723432
50-150	85/40/200	28	7321677234332	723433
50-200	85/40/250	34	7321677234349	723434
50-300	105/40/350	60	7321677234363	723436
50-400	120/50/450	118	7321677234370	723437
50-500	140/50/550	172	7321677234387	723438
50-600	150/50/650	215	7321677234394	723439

Internal cantilever arm W17

Internal cantilever arm to be used for invisible mounting inside cable tray W3/40. Material: Sheet steel, hot-dip galvanized.



W17/40-100	140/55/119	16	7321677345724	734572
W17/40-200	140/55/219	35	7321677345731	734573
W17/40-300	165/75/319	80	7321677345748	734574
W17/40-400	165/75/419	100	7321677345755	734575

Adjustable internal cantilever arm W1840

Adjustable internal cantilever arm to be used for invisible mounting inside cable trays W3/40. Adjustability 0-25 mm (W1840-100) and 0-50 mm (W1840-200-600). Material: Sheet steel, hot-dip galvanized.



W1840-100	160/60/88	36	7321677345786	734578
W1840-200	160/60/188	47	7321677345793	734579
W1840-300	185/60/289	120	7321677345809	734580
W1840-400	185/60/389	139	7321677345816	734581
W1840-500	185/60/489	156	7321677345823	734582
W1840-600	185/60/589	175	7321677345830	734583

Pendant bracket W81

Pendant bracket W81 is mounted under lighting trunking W70-50 and is attached with screw set W37. Pendant rail W32 is mounted mounted using screw set W37. Adjustable to ±18 mm. Material: Sheet steel, hot-dip galvanized.



W81 M6	140/2/76	4.1	7321677687381	CSU795377
--------	----------	-----	---------------	------------------

Wire Bracket W70-50

Wire bracket for screwless fixation, central suspension of lighting trunking W70-50. Material: Steel, hot-dip galvanized.



Wire bracket	70/52/58	2.2	3606480994883	CSU795370
--------------	----------	-----	---------------	------------------

Back plate 40

Back plate to be used for installation behind Cantilever arm 50 and 50L to reduce the surface pressure on porous walls. Material: Steel, hot-dip galvanized.



40	150/-/60	55	7321677687381	768738
----	----------	----	---------------	---------------

Mounting rail 40

Mounting rail to be used for wall installation of cantilever arms on porous walls to reduce the surface pressure or to enable height adjustment of cantilever arms. Material: Steel, hot-dip galvanized.



40	48/26/270	56	7321677170012	717001
----	-----------	----	---------------	---------------

Steel cable trays

Hot-dip galvanized - Corrosion class C3, C4

Vertical pieces

Type	Dimensions A/B/C mm		Weight kg/100 pcs	EAN code	Ref. No.
Vertical piece 2					
Vertical piece to be used for installation of Support bracket W1940, symmetrical loading. Can be joined to Pendant/fixing rail 24/34 with Pendant joint 2J. Material: Steel, hot-dip galvanized.					
2-300	279/80/135		52	7321677171910	717191
2-400	392/80/135		62	7321677171927	717192
2-500	504/80/135		72	7321677171934	717193
2-700	729/80/135		93	7321677171941	717194
2-1000	1022/80/135		120	7321677171958	717195
Vertical piece 2F					
Vertical piece to be used for installation of Internal cantilever arm W17/40, Adjustable cantilever arm W18/40 or Cantilever arm 50/50L. Can be joined to Pendant/fixing rail 24/48 with Pendant joint 2FJ. Material: Steel, hot-dip galvanized.					
2F-280	280/80/135		80	7321677171965	717196
2F-370	370/80/135		100	7321677171972	717197
2F-505	505/80/135		130	7321677171989	717198
2F-730	730/80/135		170	7321677171996	717199
2F-1000	1000/80/135		220	7321677172009	717200
2F-1500	1495/80/135		290	7321677872763	787276

Ceiling brackets

Ceiling attachment W31					
Ceiling attachment to be used for installations with Pendant rail W32. Material: Sheet steel, hot-dip galvanized.					
W31	70/64/25		6.5	7321677346196	734619
Ceiling bracket 5					
Ceiling bracket to be used for installations with Pendant/Fixing rails 24/34 and 24/48. Screw not included. Material: Steel, hot-dip galvanized.					
5	100/135/40		35	7321677186402	718640
Ceiling bracket 5TPA					
Ceiling bracket with telescopic function, to be used for mounting of various sizes of trapezoid plates. Including screw MVBF 8x16 and nut M6MF8. Breaking load: 150 kg without deformation. Material: Steel, hot-dip galvanized.					
5TPA	50/76/79-118		14	7321677334872	733487
Ceiling bracket 5TP					
Ceiling bracket to be used for installations of Vertical pieces 2, 2F and 20 in ceilings with a trapezoidal sheet profile. Material: Steel, hot-dip galvanized.					
5TP	75/35/50		12	7321677131532	713153

Pendant/Fixing rails

Pendant rail W32					
Pendant rail to be installed in ceilings in combination with ceiling attachment W31. Material: Sheet steel, hot-dip galvanized.					
W32	3000/20/20		180	7321677346202	734620
Pendant/Fixing rail 24/34					
Pendant/Fixing rail for mounting of support brackets, cantilever arms, etc. Material: Steel, hot-dip galvanized.					
24/34	2970/16/42		240	7321677158799	715879

Steel cable trays

Hot-dip galvanized - Corrosion class C3, C4

Pendant/Fixing rails

Type	Dimensions A/B/C mm		Weight kg/100 pcs	EAN code	Ref. No.
Pendant/Fixing rail 24/48					
Pendant/Fixing rail for mounting of support brackets, cantilever arms, etc. Material: Steel, hot-dip galvanized.					
24/48	1000/26/48		175	3606481317865	CSU795565
24/48	2970/26/48		520	7321677050932	705093
24/48	5940/26/48		1120	7321677317196	731719

P440345



Fixing rail 24/26x53 for casting-in					
Fixing rail for casting-in in wall and ceilings. Material: Steel, hot-dip galvanized.					
24/26x53	4000/26/53		970	7321677680634	768063

P438850



Pendant attachment W21					
Pendant attachment to be used in combination with pendant rail W32, to construct a ceiling suspension. Material: Sheet steel, hot-dip galvanized.					
W21	97/50/21		12	7321677346189	734618

PTCSU-0010



Pendant bars

Pendant bar 1					
Pendant bar to be installed in order to reduce the deflection of heavily loaded vertical pieces. Installed with T-bolt and Expansion bolt. Material: Steel, hot-dip galvanized.					
1-300	315/161/40		35	7321677176403	717640
1-500	515/166/40		53	7321677176410	717641
1-800	815/246/40		82	7321677176427	717642
1-1500	1296/35/50		560	7321677189038	718903

P440346



P440024



Bracket 60/40					
Bracket to be used together with Pendant/fixing rail 24/34 to reduce the deflection of long vertical pieces. Material: Steel, hot-dip galvanized.					
60/40	95/23/40		10	7321677189045	718904

P438856



Pendant joints

Pendant joint 2J and 2FJ					
Pendant joint to be used for joining pendant/fixing rails and vertical pieces. Screws M8x16 and nuts included. Material: Steel, hot-dip galvanized.					
2J	200/48/18		43	7321677131778	713177
2FJ	200/55/18		46	7321677131785	713178

P440347





P438860







Steel cable trays

Hot-dip galvanized - Corrosion class C3, C4



Angle brackets

	Type	Dimensions A/B/C mm 	Weight kg/100 pcs	EAN code	Ref. No.
PTGSU-001 	Angle bracket W8				
	Angle bracket to be mounted inside a cable tray W3 for horizontal installation to the wall or vertical installation to the floor. Can also be mounted as a pendant bracket in the lighting trunking W70. Material: Sheet steel, hot-dip galvanized.				
	W8	80/38/45	6	7321677288830	728883
PTGSU-002 	Angle bracket W8S				
	Universal angle bracket to be used for various installations of pendant/fixing rail 24/34, support bracket, etc. Material: Sheet steel, hot-dip galvanized.				
	W8S	120/30/30	8	7321677268733	726873



Mounting rails/lashing wire

P1838271 	Mounting rail WMS25L				
	Mounting rail to be used for installation directly on wall for lashing of cables. Material: Steel, hot-dip galvanized.				
	WMS25L	3/25/2500	141	3606489584955	CSU795597
P140226 	Lashing wire				
	Lashing wire to be used for lashing of wires on cable ladders. Material: Stainless steel, PVC.				
	HTR-2303, white PVC	Ø1.25	1.3/100 m	7321677136865	713686
P140225 	HTR-2313, black PVC	Ø1.25	1.3/100 m	7321677136872	713687
	Lashing wire to be used for lashing of wires on cable ladders. Material: PVC.				
P140226 	HT-2304, white	Ø1.5	1.8/100 m	7321677136841	713684
	P140225 	HT-2314, black	Ø1.5	1.8/100 m	7321677136858

End plugs

P140067 	End plug 28C and E				
	End plug to be mounted on pendant ends to provide protection against personal injury and to make the ends of the profiles more conspicuous. Material: PP/TPE, orange.				
	28C for Vertical piece 2 and Pendant/fixing rail 24/34	25/19/46	0.5	7321677898756	789875
P140069 	28E for Vertical piece 2F and Pendant/fixing rail 24/48	24/30/52	0.5	7321677090211	709021

Accessories

P148804 	Strip fixing W44				
	Strip fixing to be used for easy fixation of cables in an unperforated cable tray W1/40 or W1/60. Material: PPE.				
	W44	5.5/25/96	1	7321677184699	718469
B224370 	Protection strip W48				
	Protection strip to be used to protect cables from sharp edges when cutting the cable tray W1/W3 or lighting trunking W70. Material: Plastic.				
	W48	10/6/720	6.1	7321677872114	787211
P143450 	Repair paint				
	Anti-corrosive repair paint Galvafruid in a 0.4 l tin for the repair of damages on pre-galvanized or hot-dip galvanized trays and accessories.				
	Anti-corrosive repair paint	-	104	7321677176373	717637

Steel cable trays

Zinkpox - Corrosion class C5-I

Cable trays, perforated

Type	Dimensions A/B/C mm	Weight kg/100 m	EAN code	Ref. No.
------	------------------------	--------------------	----------	----------

PTCSU-0018



Cable tray W3
 Perforated cable tray for indoor or outdoor industrial applications. System height 40 mm. Provided with holes Ø 5.8 mm at the tray end to be used for fixation of joints. Oval holes along the lateral sides of the tray can be used for mounting of accessories.
 Material: Sheet steel, Zinkpox coated white.
 Contact Wibe customer service for quotation.

ODAW35892-bis



Installation tray W4
 Perforated installation tray for indoor or outdoor industrial applications. To be used when leading cables down from a cable ladder to machine cabinets, etc. Provided with holes Ø 3.5 mm in the bottom segment of the tray for the clamping of cables with plate screws.
 Material: Sheet steel, Zinkpox coated white.

W4-50	15/50/3000	57	7321677359998	735999
W4-75	15/75/3000	76	7321677360000	736000
W4-100	15/100/3000	93	7321677360017	736001
W4-150	15/150/3000	125	7321677360024	736002
W4-200	15/200/3000	195	7321677360031	736003
W4-250	15/250/3000	228	7321677360048	736004
W4-300	15/300/1960	238	7321677360055	736005
W4-400	15/400/1960	313	7321677360062	736006

Lighting trunking

Lighting trunking W70-50, -70, -100

PTCSU-0019



Cable tray with bottom perforation for indoor applications in dry environments. System height 40 mm, length 3000 mm. Oval holes 9x5.8 mm on the lateral sides of the tray end can be used for fixation of joints.
 The oval hole pattern at the base of the tray can be used for mounting of lighting fixtures. On every 500 mm an oval hole is placed to easily guide fast connectors into the tray.
 Material: Sheet steel, Zinkpox coated white.



W70-50	40/50/3000	285	3606480756122	CSU795219
W70-70	40/70/3000	293	3606480464843	CSU794531
W70-100	40/100/3000	346	3606480464850	CSU794532

Steel cable trays

Zinkpox - Corrosion class C5-I

Covers

Type	Dimensions A/B/C mm		Weight kg/100 pcs	EAN code	Ref. No.
Cover W5					
Cover to be used to protect the cables inside the cable tray against damages, dust, liquids, UV-influence, etc. Material: Sheet steel, Zinkpox coated white.					
W5-70	10/71/2000		160	7321677823635	782363
W5-100	10/101/2000		210	7321677823642	782364
W5-150	10/151/2000		290	7321677823659	782365
W5-200	10/201/2000		370	7321677823666	782366
W5-300	10/301/2000		540	7321677823673	782367
W5-400	10/401/2000		710	7321677823680	782368
W5-500	10/501/2000		880	7321677823697	782369
W5-600	10/601/2000		1050	7321677823703	782370
Cover clamp W62					
Cover clamp to be used for the fixing of covers on cable trays W3 as well as on lighting trunking W70. Material: Stainless steel 304.					
W62	-/15/10.5		0.8	7321677301867	730186

Joints

Joint W7/40					
To be used as a joint for cable tray W3/40 and for lighting trunking W70. Material: Sheet steel, Zinkpox coated white.					
W7/40-50	38/46/200		18	7321677912827	791282
W7/40-70	38/66/200		21	7321677912834	791283
W7/40-100	38/96/200		26	7321677912841	791284
W7/40-150	38/146/200		34	7321677912858	791285
W7/40-200	38/196/200		42	7321677912865	791286
W7/40-300	38/296/300		107	7321677912872	791287
W7/40-400	38/396/300		137	7321677912889	791288
W7/40-500	38/496/300		166	7321677912896	791289
W7/40-600	38/596/300		195	7321677912902	791290
Side joint W49					
Side joint to be used for straight joining of cable tray W3/40. Material: Sheet steel, Zinkpox coated white.					
W49/40	37.5/-/300		17	7321677902316	790231
Joint W2					
Side joint to be used for straight joining of installation tray W4. Material: Sheet steel, Zinkpox coated white.					
W2	15/25/200		8	7321677885756	788575
T-joint W9					
T-joint to be used to construct T-sections or X-sections. Also used for oblique branches. The ref. number includes two pieces of T-joints and Screw set W38P. Material: Sheet steel, Zinkpox coated white.					
W9/40	40/72.5/20		6	7321677831289	783128

Steel cable trays

Zinkpox - Corrosion class C5-I

Bends

Type	Dimensions A/B/C mm		Weight kg/100 m	EAN code	Ref. No.
------	------------------------	---	--------------------	----------	----------

90° bend W10F

Horizontal 90° bend to be used for cable trays W3/40. Push-in assembly.
Material: Sheet steel, Zinkpox coated white.



W10/40-50 (flat)	38/183/183		14.9	3606480994968	CSU795382
W10F/40-50	38/47/119		14	7321677836000	783600
W10F/40-70	38/67/153		23	7321677836017	783601
W10F/40-100	38/97/204		39	7321677836024	783602
W10F/40-150	38/147/290		74	7321677836031	783603
W10F/40-200	38/197/375		119	7321677836048	783604
W10F/40-300	38/297/480		242	7321677836055	783605
W10F/40-400	38/397/580		353	7321677836062	783606
W10F/40-500	38/497/714		528	7321677836079	783607
W10F/40-600	38/597/814		685	7321677836086	783608

Adjustable bend W10S

Adjustable bend to be used for horizontal angling from 105° to 165° in steps of 7.5°. Push-in assembly.
Material: Sheet steel, Zinkpox coated white.



W10S/40-50	38/47/47		9	7321677828500	782850
W10S/40-70	38/67/67		10	7321677828517	782851
W10S/40-100	38/97/97		13	7321677828524	782852
W10S/40-150	38/147/147		24	7321677828531	782853
W10S/40-200	38/197/197		40	7321677828548	782854
W10S/40-300	38/297/297		94	7321677828555	782855
W10S/40-400	38/397/397		156	7321677828562	782856
W10S/40-500	38/497/497		270	7321677828579	782857
W10S/40-600	38/597/597		380	7321677828586	782858

90° bend W4

Horizontal 90° bend to be used for cable tray W4. To be mounted on the outside of the tray and attached in the bottom segment with screw set W38P.
Material: Sheet steel, Zinkpox coated white.



W4-50	16/52/-		10	7321677936779	793677
W4-75	16/77/-		15	7321677936786	793678
W4-100	16/102/-		22	7321677936793	793679
W4-150	16/152/-		37	7321677936809	793680
W4-200	16/202/-		55	7321677936816	793681
W4-250	16/252/-		77	7321677936823	793682
W4-300	16/302/-		102	7321677936830	793683
W4-400	16/402/-		161	7321677936847	793684

Junctions

T-junction W12F

T-junction to be used for 90° horizontal junction of cable trays W3/40. Push-in assembly.
Material: Sheet steel, Zinkpox coated white.

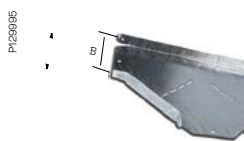
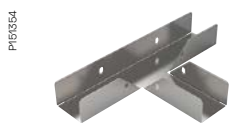

W12/40-50 (flat)	-/185/248		23.2	3606480995002	CSU795386
W12F/40-50	38/47/171		26	7321677836208	783620
W12F/40-70	38/67/219		35	7321677836215	783621
W12F/40-100	38/97/312		60	7321677836222	783622
W12F/40-150	38/147/432		110	7321677836239	783623
W12F/40-200	38/197/553		192	7321677836246	783624
W12F/40-300	38/297/662		300	7321677836253	783625
W12F/40-400	38/397/762		428	7321677836260	783626
W12F/40-500	38/497/932		640	7321677836277	783627
W12F/40-600	38/597/1032		817	7321677836284	783628

Steel cable trays

Zinkpox - Corrosion class C5-I

Junctions

Type	Dimensions A/B/C mm		Weight kg/100 pcs	EAN code	Ref. No.
X-junction W13F					
X-junction to be used for 90° horizontal junction of cable trays W3/40. Push-in assembly. Material: Sheet steel, Zinkpox coated white.					
W13/40-50 (flat)	-/248/248		28.1	3606480995040	CSU795390
W13F/40-50	38/47/148		27	7321677836406	783640
W13F/40-70	38/67/217		43	7321677836413	783641
W13F/40-100	38/97/313		74	7321677836420	783642
W13F/40-150	38/147/434		147	7321677836437	783643
W13F/40-200	38/197/555		243	7321677836444	783644
W13F/40-300	38/297/662		370	7321677836451	783645
W13F/40-400	38/397/762		510	7321677836468	783646
W13F/40-500	38/497/932		766	7321677836475	783647
W13F/40-600	38/597/1032		966	7321677836482	783648

P49356

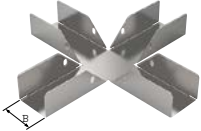

PTCSU-0070



Vertical risers

Vertical riser W11					
Vertical riser to be used as internal or external riser for cable tray W3/40. The riser is delivered flat and can be bent to the desired angle up to 90°. Push-in assembly. Material: Sheet steel, Zinkpox coated white.					
W11/40-50	-/48/150		8	7321677830404	783040
W11/40-70	-/68/150		10	7321677830411	783041
W11/40-100	-/98/150		12	7321677830428	783042
W11/40-150	-/148/150		17	7321677830435	783043
W11/40-200	-/198/200		28	7321677830442	783044
W11/40-300	-/298/200		39	7321677830459	783045
W11/40-400	-/398/200		50	7321677830466	783046
W11/40-500	-/498/200		61	7321677830473	783047
W11/40-600	-/598/200		73	7321677830480	783048

00X73228



Vertical riser W4					
Vertical riser suitable for installation tray W4. To be used as internal or external riser. The riser is delivered flat and can be bent to the desired angle up to 90°. Material: Sheet steel, Zinkpox coated white.					
W4-50	16/52/250		15	7321677936694	793669
W4-75	16/77/250		19	7321677936700	793670
W4-100	16/102/250		24	7321677936717	793671
W4-150	16/152/250		33	7321677936724	793672
W4-200	16/202/250		42	7321677936731	793673
W4-250	16/252/250		58	7321677936748	793674
W4-300	16/302/250		68	7321677936755	793675
W4-400	16/402/250		77	7321677936762	793676

794035



Reducers

Reducer W28/40					
Reducer for cable tray W3, system height 40. To be used together with side joint W49 in side transitions. In centered transitions only two reducers W28 are necessary. Material: Sheet steel, Zinkpox coated white.					
W28/40-50	37.5/50/200		15	7321677935970	793597
W28/40-100	37.5/100/200		17	7321677935987	793598
W28/40-150	37.5/150/200		20	7321677935994	793599
W28/40-200	37.5/200/200		23	7321677936007	793600
W28/40-250	37.5/250/200		26	7321677936014	793601
W28/40-300	37.5/300/200		29	7321677936021	793602
W28/40-350	37.5/350/200		32	7321677936038	793603
W28/40-400	37.5/400/200		36	7321677936045	793604
W28/40-450	37.5/450/200		39	7321677936052	793605
W28/40-500	37.5/500/200		41	7321677936069	793606

PTCSU-0026



Steel cable trays

Zinkpox - Corrosion class C5-I

End covers

Type	Dimensions A/B/C mm		Weight kg/100 pcs	EAN code	Ref. No.
End cover W45					
End cover to be mounted at the ends of cable trays W3/40 and of lighting trunking W70. Provided with oval holes 6x55 mm on the sides. Push-in assembly. Material: Sheet steel, Zinkpox coated white.					
W45/40-70	38/100/68		8	7321677830008	783000
W45/40-100	38/100/98		9	7321677830015	783001
W45/40-150	38/100/148		10	7321677830022	783002
W45/40-200	38/100/198		12	7321677830039	783003
W45/40-300	38/100/298		15	7321677830046	783004
W45/40-400	38/100/398		18	7321677830053	783005
W45/40-500	38/100/498		21	7321677830060	783006
W45/40-600	38/100/598		24	7321677830077	783007

Box plates

Junction box plate W24					
Junction box plate with perforated hole pattern. To be used for the installation of junction boxes, light fittings, etc., in cable trays W3/40 and in lighting trunking W70. Material: Sheet steel, Zinkpox coated white.					
W24/40	161/43/200		27	7321677831302	783130





Screws, bolts and nuts

Screw set 22S					
Screw set to be used for installation of Ceiling bracket 5 on Pendant/fixing rails 24/34 and 24/48, Angle bracket 5L against the back of Pendant/fixing rails, Pendant/fixing rails back to back. Set including screw MVBF 8x16 and nut M6MF8. Material: Steel, hot-dip galvanized.					
22S	-		1.9	7321677136940	713694
Screw set W34					
Screw set to be used for mounting of Cable tray W3 onto Cantilever arm 50 and Angle bracket W8 onto Pendant rail W32, Junction box plate W24 onto W3 Cable tray or Lighting trunking W70, as well as for assembly of Angle bracket W8 (light fitting bracket) and for joining of W4 Installation trays. Set including screw MSCS 6x12 and nut M6MF6. Material: Steel, Dacromet.					
W34	10/10/16		0.8	7321677346462	734646
Screw set W38P C4					
Screw set including screw and nut, to be used for the mounting of joints, bends, junctions. Material: Steel, Dacromet.					
Screw set W38P C4	-		0.4	7321677351770	735177
T-bolt 26U					
T-bolt to be used for mounting with all vertical pieces (except Vertical piece 2) and with Pendant/fixing rail 24/48. Material: Steel, hot-dip galvanized.					
26U M8x30	50/44/18		6.8	3606489579777	CSU795595
26U M10x30	50/44/18		6.8	3606489579715	CSU795589
26U M10x40	60/44/18		8.2	3606489579722	CSU795590
26U M10x50	70/44/18		9.5	3606489579739	CSU795591
Spring nut M8					
Spring nut to be used for fastening of accessories (control panels, etc.) on Pendant/fixing rail 24/48. Material: Steel, hot-dip galvanized.					
M8	-		2.7	7321677164073	716407
Locking plug W41					
Locking plug to be used for quick locking of joints, bends and branches in cable trays and lighting trunking. Material: PP+GF10.					
W41	Ø14/10.5		0.1	7321677186457	718645

Steel cable trays

Zinkpox - Corrosion class C5-I

Threaded rods

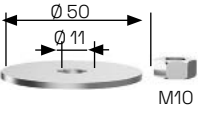
Type	Dimensions A/B/C mm		Weight kg/100 pcs	EAN code	Ref. No.
Threaded rod W76					
Threaded rod for M8 ceiling mounting of cable support. For fixing, use Flange Nut M8 and for extension, Distance nut M8. Material: Steel, hot-dip galvanized.					
 CSU0805000	W76/M8	8/8/1000	32	3606480483783	CSU794697
		8/8/2000	64	3606480483776	CSU734698
Flange nut					
Flange Nut M8 to be mounted on Threaded rod W76. Intended for ceiling mounting of cable support. Material: Steel, hot-dip galvanized.					
 P40164	Flange nut M8	17/17/8	1	3606480483806	CSU794715
Distance nut					
Distance nut M8 to be used as an extension and a coupler of Threaded rod W76. Intended for ceiling mounting of cable support. Material: Steel, hot-dip galvanized.					
 PTCSU-0043	Distance nut M8	15/15/30	4	3606480483790	CSU794699
Nut M8, M10					
Nut to be used for the mounting of Threaded rod W76 M8 and M10 respectively. Material: Steel, hot-dip galvanized.					
 CSU0223896	Nut M8	-	0.54	7321677250851	725085
	Nut M10	-	1.1	7321677239382	723938
Mounting set W78					
Mounting set including washer Ø50 and nut M10, to be used for mounting of threaded rod W76 in plate material or light concrete ceilings. Material: Steel, hot-dip galvanized.					
 77069	W78	Ø50/M10	5.5	7321677170692	717069

Brackets

Support bracket W1940					
Support bracket to be used for invisible installation of cable trays W3/40. Material: Sheet steel, Zinkpox coated white.					
 PTCSU-0037	W1940-100	36/65/90	11	7321677830602	783060
	W1940-200	36/65/190	22	7321677830619	783061
	W1940-300	36/65/289	50	7321677830626	783062
	W1940-400	36/65/389	68	7321677830633	783063
	W1940-500	36/65/489	91	7321677830640	783064
	W1940-600	36/65/589	110	7321677830657	783065

Cantilever arms

Cantilever arm 50					
Cantilever arm for mounting on walls, pendant/fixing rails or vertical pieces. Material: Sheet steel, Zinkpox coated white.					
 P40016	50-100	85/40/150	24	7321677234400	723440
	50-150	85/40/200	28	7321677234417	723441
	50-200	85/40/250	34	7321677234424	723442
	50-300	105/40/350	60	7321677234448	723444
	50-400	120/50/450	228	7321677234455	723445
	50-500	140/50/550	172	7321677234462	723446
	50-600	150/50/650	215	7321677234479	723447

Steel cable trays

Zinkpox - Corrosion class C5-I

Cantilever arms

Type	Dimensions A/B/C mm 	Weight kg/100 pcs	EAN code	Ref. No.
------	--	----------------------	----------	----------

Internal cantilever arm W17/40

Internal cantilever arm to be used for invisible mounting inside cable tray W3/40.
Material: Sheet steel, Zinkpox coated white.

W17/40-100	140/55/119	16	7321677830664	783066
W17/40-200	140/55/219	35	7321677830671	783067
W17/40-300	165/75/319	80	7321677830688	783068
W17/40-400	165/75/419	100	7321677830695	783069

Adjustable internal cantilever arm W1840

Adjustable internal cantilever arm to be used for invisible mounting inside cable trays W3/40. Adjustability 0-25 mm (W1840-100) and 0-50 mm (W1840-200 to 600).
Material: Sheet steel, Zinkpox coated white.

W1840-100	160/60/88	36	7321677830183	783018
W1840-200	160/60/188	47	7321677830190	783019
W1840-300	185/60/289	120	7321677830206	783020
W1840-400	185/60/389	139	7321677830213	783021
W1840-500	185/60/489	156	7321677830220	783022
W1840-600	185/60/589	175	7321677830237	783023

Pendant bracket W81

Pendant bracket W81 is mounted under lighting trunking W70-50 and is attached with screw set W37. Pendant rail W32 is mounted using screw set W37. Adjustable to ± 18 mm.
Material: Sheet steel, Zinkpox coated white.

W81 M6	140/2/76	4.1	3606480994920	CSU795378
--------	----------	-----	---------------	------------------

Wire bracket W70-50

Wire bracket for screwless fixation, central suspension of lighting trunking W70-50.
Material: Steel, hot-dip galvanized.

Wire bracket	70/52/58	2.2	3606480994883	CSU795370
--------------	----------	-----	---------------	------------------

Back plate 40

Back plate to be used for installation behind Cantilever arm 50 and 50L to reduce the surface pressure on porous walls.
Material: Sheet steel, Zinkpox coated white.

40	150/-/60	55	7321677140299	714029
----	----------	----	---------------	---------------

Mounting rail 40

Mounting rail to be used for wall installation of cantilever arms on porous walls to reduce the surface pressure or to enable height adjustment of cantilever arms.
Material: Sheet steel, Zinkpox coated white.

40	48/26/270	56	7321677290451	729045
----	-----------	----	---------------	---------------

Vertical pieces

Vertical piece 2

Vertical piece to be used for installation of Support bracket W1940, symmetrical loading. Can be joined to Pendant/fixing rail 24/34 with Pendant joint 2J.
Material: Sheet steel, Zinkpox coated white.

2-300	279/80/135	52	7321677162833	716283
2-400	392/80/135	62	7321677162840	716284
2-500	504/80/135	72	7321677162857	716285
2-700	729/80/135	93	7321677162864	716286
2-1000	1022/80/135	120	7321677162871	716287

Vertical piece 2F

Vertical piece to be used for installation of Internal cantilever arm W17/40, Adjustable cantilever arm W18/40 or Cantilever arm 50/50L. Can be joined to Pendant/fixing rail 24/48 with Pendant joint 2FJ.
Material: Sheet steel, Zinkpox coated white.

2F-280	280/80/135	80	7321677172016	717201
2F-370	370/80/135	100	7321677172023	717202
2F-505	505/80/135	130	7321677172030	717203
2F-730	730/80/135	170	7321677172047	717204
2F-1000	1000/80/135	220	7321677172054	717205
2F-1500	1495/80/135	290	7321677872770	787277

Steel cable trays

Zinkpox - Corrosion class C5-I

Ceiling brackets

Type	Dimensions A/B/C mm		Weight kg/100 pcs	EAN code	Ref. No.
Ceiling attachment W31					
Ceiling attachment to be used for installations with Pendant rail W32. Material: Sheet steel, Zinkpox coated white.					
W31	70/64/25		6.5	7321677831203	783120
Ceiling bracket 5					
Ceiling bracket to be used for installations with Pendant/Fixing rails 24/34 and 24/48. Screw not included. Material: Sheet steel, Zinkpox coated white.					
5	100/135/40		35	7321677162932	716293
Ceiling bracket 5TP					
Ceiling bracket to be used for installations of Vertical pieces 2, 2F and 20 in ceilings with a trapezoidal sheet profile. Material: Steel, Zinkpox coated white.					
5TP	75/35/50		12	7321677162956	716295

Pendant/Fixing rails

Pendant rail W32					
Pendant rail to be installed in ceilings in combination with ceiling attachment W31. Material: Sheet steel, Zinkpox coated white.					
W32	3000/20/20		180	7321677831227	783122
Pendant/Fixing rail 24/34					
Pendant/Fixing rail for mounting of support brackets, cantilever arms, etc. Material: Sheet steel, Zinkpox coated white.					
24/34	2970/16/42		240	7321677163090	716309
Pendant/Fixing rail 24/48					
Pendant/Fixing rail for mounting of support brackets, cantilever arms, etc. Material: Steel, Zinkpox coated white.					
24/48	1000/26/48		175	3606481317865	CSU795568
24/48	2970/26/48		520	7321677163069	716306
24/48	5940/26/48		1120	7321677317240	731724
Pendant attachment W21					
Pendant attachment to be used in combination with pendant rail W32, to construct a ceiling suspension. Material: Sheet steel, Zinkpox coated white.					
W21	97/50/21		12	7321677831074	783107

Steel cable trays

Zinkpox - Corrosion class C5-I

Pendant bars

Type	Dimensions A/B/C mm		Weight kg/100 pcs	EAN code	Ref. No.
Pendant bar 1					
Pendant bar to be installed in order to reduce the deflection of heavily loaded vertical pieces. Installed with T-bolt and Expansion bolt. Material: Sheet steel, Zinkpox coated white.					
1-300	315/161/40		35	7321677176434	717643
1-500	515/166/40		53	7321677176441	717644
1-800	815/246/40		82	7321677176458	717645
1-1500	1296/35/50		560	7321677205301	720530
Bracket 60/40					
Bracket to be used together with Pendant/fixing rail 24/34 to reduce the deflection of long vertical pieces. Material: Sheet steel, Zinkpox coated white.					
60/40	95/23/40		10	7321677205318	720531

Pendant joints

Pendant joint 2J and 2FJ					
Pendant joint to be used for joining pendant/fixing rails and vertical pieces. Screws M8x16 and nuts included. Material: Steel, Zinkpox coated white.					
2J	200/48/18		43	7321677163038	716303
2FJ	200/55/18		46	7321677163045	716304

Angle brackets









Angle bracket W8					
Angle bracket to be mounted inside a cable trays W3 for horizontal installation to the wall or vertical installation to the floor. Can also be mounted as a pendant bracket in the lighting trunking W70. Material: Sheet steel, Zinkpox coated white.					
W8	80/38/45		6	7321677831241	783124
Angle bracket W8S					
Universal angle bracket to be used for various installations of pendant/fixing rail 24/34, support bracket, etc. Material: Sheet steel, Zinkpox coated white.					
W8S	120/30/30		8	7321677831265	783126

End plugs

End plug 28C and E					
End plug to be mounted on pendant ends to provide protection against personal injury and to make the ends of the profiles more conspicuous. Material: PP/TPE, orange.					
28C for Vertical piece 2 and Pendant/fixing rail 24/34	25/19/46		0.5	7321677898756	789875
28E for Vertical piece 2F and Pendant/fixing rail 24/48	24/30/52		0.5	7321677090211	709021

Steel cable trays

Zinkpox - Corrosion class C5-I

Accessories					
Type	Dimensions A/B/C mm		Weight kg/100 pcs	EAN code	Ref. No.
Lashing wire					
Lashing wire to be used for lashing of wires on cable ladders. Material: Stainless steel, PVC.					
P140226 	HTR-2303, white PVC	Ø1.25	1.3/100 m	7321677136865	713686
P140225 	HTR-2313, black PVC	Ø1.25	1.3/100 m	7321677136872	713687
Lashing wire to be used for lashing of wires on cable ladders. Material: PVC.					
P140226 	HT-2304, white	Ø1.5	1.8/100 m	7321677136841	713684
P140225 	HT-2314, black	Ø1.5	1.8/100 m	7321677136858	713685
Strip fixing W44					
Strip fixing to be used for easy fixation of cables in an unperforated cable tray W1/40 or W1/60. Material: PPE.					
P146804 	W44	5.5/25/96	1	7321677184699	718469
Protection strip W48					
Protection strip to be used to protect cables from sharp edges when cutting the cable tray W1/W3 or lighting trunking W70. Material: Plastic.					
PT3SU-0013 	W48	10/6/720	6.1	7321677872114	787211
Repair paint					
Repair paint for the repair of minor damages of powder-coated products. Colour white RAL 9003, gloss 30.					
P149450 	Spray bottle, 0.4 litres	—	60	7321677397136	739713

Steel cable trays

Stainless steel - Corrosion class C5-M

Cable trays, perforated

Type	Dimensions A/B/C mm 	Weight kg/100 m	EAN code	Ref. No.
Installation tray W4				
Perforated installation tray for both indoor and outdoor applications having high demands on corrosion resistance. To be used when leading cables down from a cable ladder to machine cabinets, etc. Provided with holes Ø 3.5 mm in the bottom segment of the tray for the clamping of cables with plate screws. Material: Stainless steel AISI316L.				
W4-50	15/50/3000	56	7321677834709	783470
W4-75	15/75/3000	73	7321677834716	783471
W4-100	15/100/3000	90	7321677834723	783472
W4-150	15/150/3000	119	7321677834730	783473
W4-200	15/200/3000	149	7321677834747	783474
W4-250	15/250/3000	181	7321677834754	783475
W4-300	15/300/3000	214	7321677834761	783476
W4-400	15/400/3000	279	7321677834778	783477

00A735902-bis

**Joints**

Type	Dimensions A/B/C mm	Weight kg/100 m	EAN code	Ref. No.
Joint W2				
Side joint to be used for straight joining of installation tray W4. Material: Stainless steel AISI316L.				
W2	15/25/200	8	7321677834877	783487

PTCSU-0023

**Bends**

Type	Dimensions A/B/C mm	Weight kg/100 m	EAN code	Ref. No.
90° bend W4				
Horizontal 90° bend to be used for cable tray W4. To be mounted on the outside of the tray and attached in the bottom segment with screw set W34. Material: Stainless steel AISI316L.				
W4-50	16/52/-	10	7321677838844	783884
W4-75	16/77/-	15	7321677838851	783885
W4-100	16/102/-	22	7321677838868	783886
W4-150	16/152/-	37	7321677838875	783887
W4-200	16/202/-	55	7321677838882	783888
W4-250	16/252/-	77	7321677838899	783889
W4-300	16/302/-	102	7321677838905	783890
W4-400	16/402/-	161	7321677838912	783891

78A077

**Vertical risers**

Type	Dimensions A/B/C mm	Weight kg/100 m	EAN code	Ref. No.
Vertical riser W4				
Vertical riser suitable for installation tray W4. To be used as internal or external riser. The riser is delivered flat and can be bent to the desired angle up to 90°. Material: Stainless steel AISI316L.				
W4-50	16/52/250	15	7321677839001	783900
W4-75	16/77/250	19	7321677839018	783901
W4-100	16/102/250	24	7321677839025	783902
W4-150	16/152/250	33	7321677839032	783903
W4-200	16/202/250	42	7321677839049	783904
W4-250	16/252/250	58	7321677839056	783905
W4-300	16/302/250	68	7321677839063	783906
W4-400	16/402/250	77	7321677839070	783907

78A093



Steel cable trays

Stainless steel - Corrosion class C5-M

Screws, bolts and nuts

	Type	Dimensions A/B/C mm 	Weight kg/100 m	EAN code	Ref. No.
P40161	Screw set 22S				
	Screw set to be used for installation of Ceiling bracket 5 on Pendant/fixing rails 24/34 and 24/48, Angle bracket 5L against the back of Pendant/fixing rails, Pendant/fixing rails back to back. Set including screw MVBF 8x16 and nut M6MF8. Material: Stainless steel AISI316.				
	22S	-	1.9	7321677255825	725582
P40166	Screw set W34				
	Screw set to be used for mounting of Angle bracket W8 onto Pendant rail W32 and for joining of W4 Installation trays. Set including screw MSCS 6x12 and nut M6MF6. Material: Stainless steel AISI316.				
	W34	10/10/16	0.8	7321677255894	725589
716546	Screw set W36				
	Screw set including bolt and nut M8 to be used for the mounting of single Pendant attachment W21 or on Support bracket/joint W7. Material: Stainless steel AISI316.				
	W36	M8	1.2	7321677255818	725581
716789	Screw set W37				
	Screw set including bolt MVBF 8x35 and nut M6MF 8, to be used for assembly of Pendant attachment W21 and Ceiling attachment W31 with Pendant rail W32, and for the joining of Pendant rail W32. Material: Stainless steel AISI316.				
	W37	M8	2.8	7321677255863	725586
T-bolt angle-0	T-bolt 26U				
	T-bolt to be used for the mounting of Cantilever arm 50 on Pendant/Fixing rail 24/48 and all vertical pieces except Vertical piece 2. Material: Stainless steel AISI316.				
	26U M8x30	50/44/18	6.8	3606489579784	CSU795596
	26U M10x30	50/44/18	6.8	3606489579746	CSU795592
	26U M10x50	70/44/18	9.5	3606489579753	CSU795593

Threaded rods

cau08050000	Threaded rod B41				
	Threaded rod according to metric standard 6G. Material: Stainless steel AISI316L.				
	B41/M8	8/8/1000	63	7332227015516	1149551
		8/8/2000	63	7332227015523	1149552
	B41/M10	10/10/1000	99	7332227015615	1149561
10/10/2000		99	7332227015622	1149562	
PTCSU-0043	Joint nut M8, M10				
	Joint nut to be used to connect two lengths of threaded rods B41. Material: Stainless steel AISI316.				
	Joint nut M8	40/15/13	5.0	7321677250844	725084
	Joint nut M10	40/18.5/16	7.2	7321677248070	724807
P40164	Flange nut B43				
	Flange nut to be mounted onto Threaded rod B41 in order to lock it to the Support hook and the Ceiling fittings. Package of 50 pcs. Material: Stainless steel AISI316L.				
	B43/M8	17/17/8	34	7332227015547	1149554
	B43/M10	20/20/15	56	7332227015646	1149564

Cantilever arms

P40016	Cantilever arm 50				
	Cantilever arm for mounting on walls, pendant/fixing rails or vertical pieces. Material: Stainless steel AISI316L.				
	50-100	85/40/150	24	7321677256181	725618
	50-150	85/40/200	28	7321677256198	725619
	50-200	85/40/250	34	7321677256204	725620
	50-300	105/40/350	60	7321677256228	725622
	50-400	120/50/450	118	7321677256235	725623
	50-500	140/50/550	172	7321677256242	725624
	50-600	150/50/650	215	7321677256259	725625

Steel cable trays

Stainless steel - Corrosion class C5-M

Vertical pieces

P33937



Type	Dimensions A/B/C mm 	Weight kg/100 pcs	EAN code	Ref. No.
------	---	-------------------	----------	----------

Vertical piece 2

Vertical piece to be used with Angle bracket W8S for symmetric loading. Can be extended by using Pendant joint 2J. Material: Stainless steel AISI316L.

2-300	279/80/135	52	7321677255573	725557
2-400	392/80/135	62	7321677255580	725558
2-500	504/80/135	72	7321677255597	725559
2-700	729/80/135	93	7321677255603	725560
2-1000	1022/80/135	120	7321677255610	725561

Vertical piece 2F

Vertical piece to be used for installation of Cantilever arm 50. Can be joined to Pendant/fixing rail 24/48 with Pendant joint 2FJ. Material: Stainless steel AISI316L.

2F-280	280/80/135	80	7321677255627	725562
2F-370	370/80/135	100	7321677255634	725563
2F-505	505/80/135	130	7321677255641	725564
2F-730	730/80/135	170	7321677255658	725565
2F-1000	1000/80/135	220	7321677255665	725566
2F-1500	1495/80/135	290	7321677872787	787278

P33939



Ceiling brackets

718816



Ceiling attachment W31

Ceiling attachment to be used for installations with Pendant rail W32. Material: Stainless steel AISI316L.

W31	70/64/25	6.5	7321677255832	725583
-----	----------	-----	---------------	---------------

P140348



Ceiling bracket 5

Ceiling bracket to be used for installations with Pendant/Fixing rails 24/34 and 24/48. Screw not included. Material: Stainless steel AISI316L.

5	100/135/40	35	7321677255733	725573
---	------------	----	---------------	---------------

Pendant/Fixing rails

PTCSU-0009



Pendant rail W32

Pendant rail to be installed in ceilings in combination with ceiling attachment W31. Material: Stainless steel AISI316L.

W32	3000/20/20	180	7321677255849	725584
-----	------------	-----	---------------	---------------

P140344



Pendant/Fixing rail 24/34

Pendant/Fixing rail for mounting of support brackets, cantilever arms, etc. Material: Stainless steel AISI316L.

24/34	293/16/42	23	7321677255740	725574
24/34	383/16/42	31	7321677255757	725575
24/34	495/16/42	40	7321677255764	725576
24/34	698/16/42	56	7321677255771	725577
24/34	990/16/42	80	7321677255788	725578
24/34	2970/16/42	240	7321677255795	725579

P140345



Pendant/Fixing rail 24/48



Pendant/Fixing rail for mounting of support brackets, cantilever arms, etc. Material: Stainless steel AISI316L.

24/48	1000/26/48	175	3606481317865	CSU795566
24/48	2970/26/48	520	7321677285952	728595
24/48	5940/26/48	1120	7321677317271	731727



Steel cable trays

Stainless steel - Corrosion class C5-M



Pendant/Fixing rails

Type	Dimensions A/B/C mm		Weight kg/100 pcs	EAN code	Ref. No.
Pendant bar 1					
Pendant bar to be installed in order to reduce the deflection of heavily loaded vertical pieces. Installed with T-bolt and Expansion bolt. Material: Stainless steel AISI316L.					
P440346 	1-500	515/166/40	53	3606480911415	CSU795328
Pendant W21					
Pendant attachment to be used in combination with pendant rail W32. Material: Stainless steel AISI316L.					
P7CSU-0010 	W21	97/50/21	12	7321677255856	725585



Pendant joints

Pendant joint 2J and 2FJ					
Pendant joint to be used for joining pendant/fixing rails and vertical pieces. Screws M8x16 and nuts included. Material: Stainless steel AISI316L.					
P440347 	2J	200/48/18	43	7321677264841	726484
P439860 	2FJ	200/55/18	46	7321677264858	726485

Angle brackets

Angle bracket W8					
Angle bracket to be mounted inside a cable tray W4 for horizontal installation to the wall or vertical installation to the floor. Can also be mounted as a pendant bracket in the W4 installation tray. Material: Stainless steel AISI316L.					
P7CSU-0011 	W8	80/38/45	6	7321677255801	725580
Angle bracket W8S					
Universal angle bracket to be used for various installations of pendant/fixing rail 24/34, support bracket, etc. Material: Stainless steel AISI316L.					
P7CSU-0012 	W8S	120/30/30	8	7321677268757	726875

End plugs

End plug 28C and E					
End plug to be mounted on pendant ends to provide protection against personal injury and to make the ends of the profiles more conspicuous. Material: PP/TPE, orange.					
P440067 	28C for Vertical piece 2 and Pendant/fixing rail 24/34	25/19/46	0.5	7321677898756	789875
P440068 	28E for Vertical piece 2F and Pendant/fixing rail 24/48	24/30/52	0.5	7321677090211	709021

Protection strip

Protection strip W48					
Protection strip to be used to protect cables from sharp edges when cutting the cable tray W4. Material: Plastic.					
P7CSU-0013 	W48	10/6/720	6.1	7321677872114	787211

Technical information

Use and installation

Technical information

Use and installation

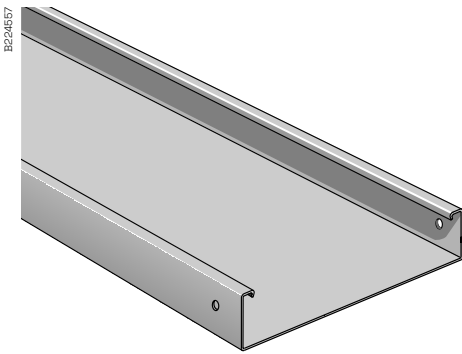

Cable tray W1/40, unperforated

Unperforated cable tray system height 40 mm. Provided with holes \varnothing 5.8 mm at the tray end to be used for fixation of joints.

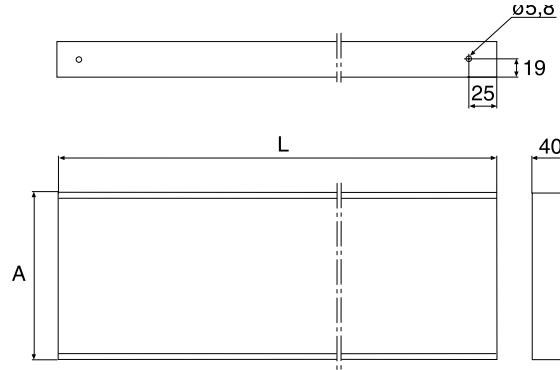

Cable tray W1 H=40 mm L=2000 mm

F1: End span, the joint position is in mid span

F2: Center span

One or more joints may be required dependent upon the product length and span.

Span 2 m

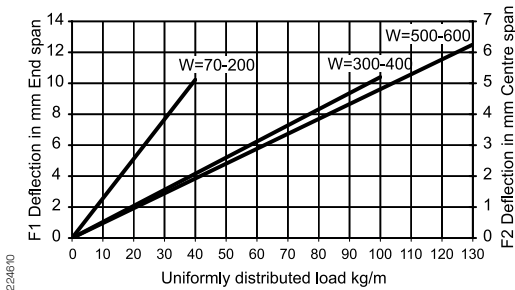
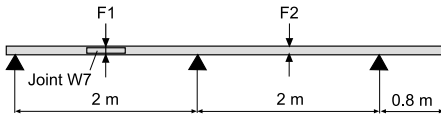

Type	A mm	L mm
Cable tray W1/40-70	70	2000
Cable tray W1/40-100	100	2000
Cable tray W1/40-200	200	2000
Cable tray W1/40-300	300	2000
Cable tray W1/40-400	400	2000
Cable tray W1/40-500	500	2000
Cable tray W1/40-600	600	2000
Cable tray W1/40-500 FS	500	2000
Cable tray W1/40-600 FS	600	2000
Cable tray W1/40-70	70	3000
Cable tray W1/40-100	100	3000
Cable tray W1/40-200	200	3000
Cable tray W1/40-300	300	3000
Cable tray W1/40-400	400	3000
Cable tray W1/40-500	500	3000
Cable tray W1/40-600	600	3000

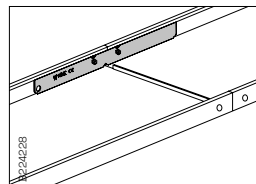

Cable tray W1/40 is joined with 2 Side joints W49/40 or Support bracket/joint W7/40.

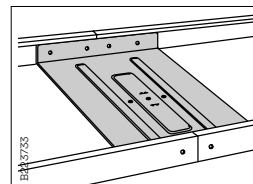

For trays 300 mm and wider we recommend to use Support bracket/joint W7/40.

Technical information

Use and installation

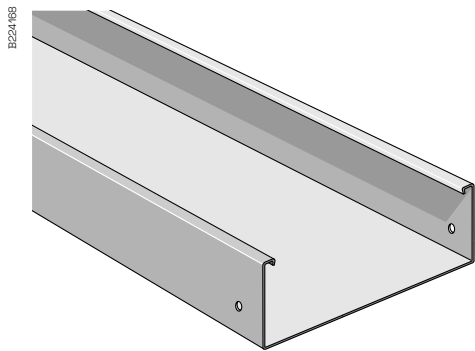

Cable tray W1/60, unperforated

Unperforated cable tray system height 60 mm. Provided with holes $\varnothing 5.8$ mm at the tray end to be used for fixation of joints.

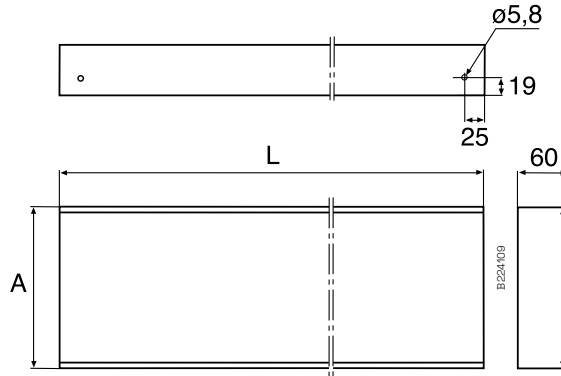

Cable tray W1 H=60 mm L=2000 mm

F1: End span, the joint position is in mid span

F2: Center span

One or more joints may be required dependent upon the product length and span.

Span 2 m

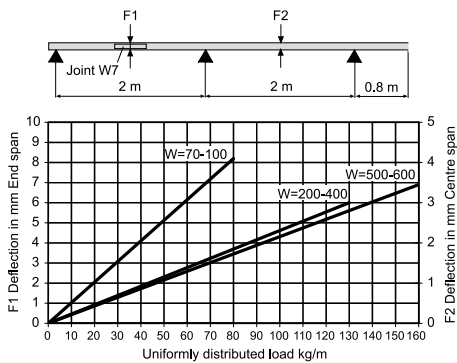

Type	A mm	L mm
Cable tray W1/60-70	70	2000
Cable tray W1/60-100	100	2000
Cable tray W1/60-200	200	2000
Cable tray W1/60-300	300	2000
Cable tray W1/60-400	400	2000
Cable tray W1/60-500	500	2000
Cable tray W1/60-600	600	2000
Cable tray W1/60-500 FS	500	2000
Cable tray W1/60-600 FS	600	2000

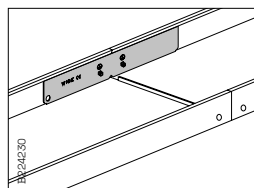

Cable tray W1/60 is joined with 2 Side joints W49/60 or Support bracket/joint W7/60.

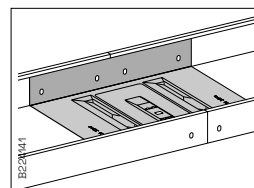

For trays 300 mm and wider we recommend to use Support bracket/joint W7/60.

Technical information

Use and installation

Cable tray W3/40, perforated

Perforated cable tray system height 40 mm. Provided with holes $\varnothing 5.8$ mm at the tray end to be used for fixation of joints. Oval holes along the lateral side of the tray can be used for mounting of accessories.

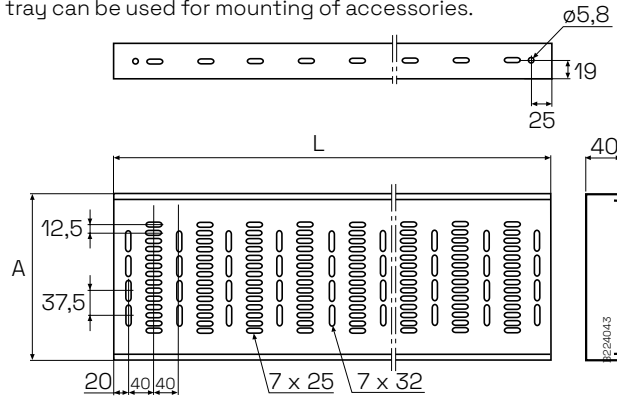
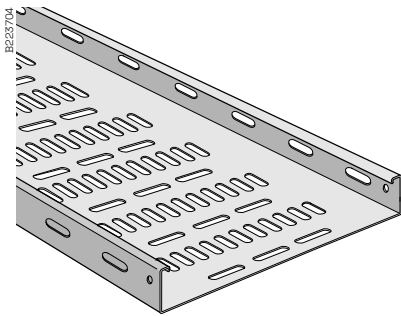

Type	A mm	L mm
Cable tray W3/40-50	50	3000
Cable tray W3/40-70	70	3000
Cable tray W3/40-100	100	3000
Cable tray W3/40-150	150	3000
Cable tray W3/40-200	200	3000
Cable tray W3/40-300	300	3000
Cable tray W3/40-400	400	3000
Cable tray W3/40-500	500	3000
Cable tray W3/40-600	600	3000

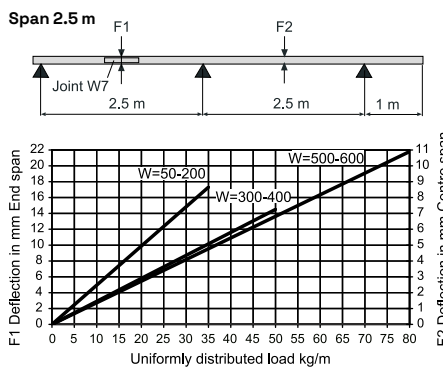
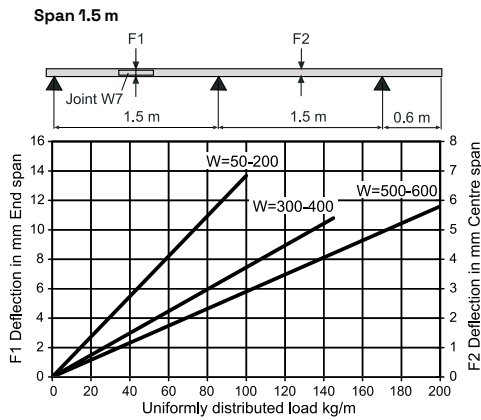

The cable trays are tested according to IEC 61537:

Cable tray W3 H=40mm
L=3000mm

F1: End span, the joint position is in mid span
F2: Center span
One or more joints may be required dependent upon the product length and span.

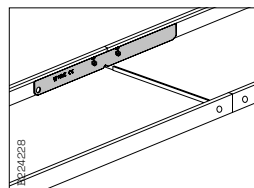
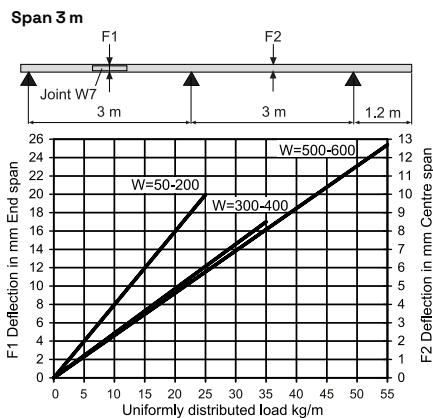
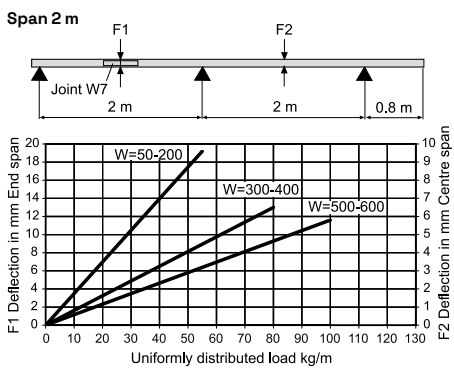

Cable tray W3/40 is joined with 2 Side joints W49/40 or Support bracket/joint W7/40.

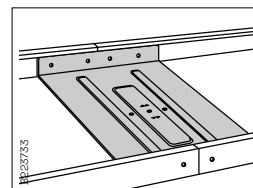

For Pre-galvanized trays 300 mm and wider we recommend to use Support bracket/joint W7/40.

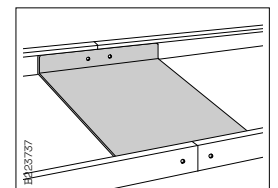

For Hot dip galvanized trays 300 mm and wider we recommend to use Joint W7/40.

Technical information

Use and installation

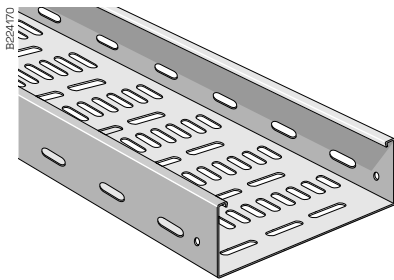

Cable tray W3/60, perforated

Perforated cable tray system height 60 mm. Provided with holes $\varnothing 5.8$ mm at the tray end to be used for fixation of joints. Oval holes along the lateral side of the tray can be used for mounting of accessories.

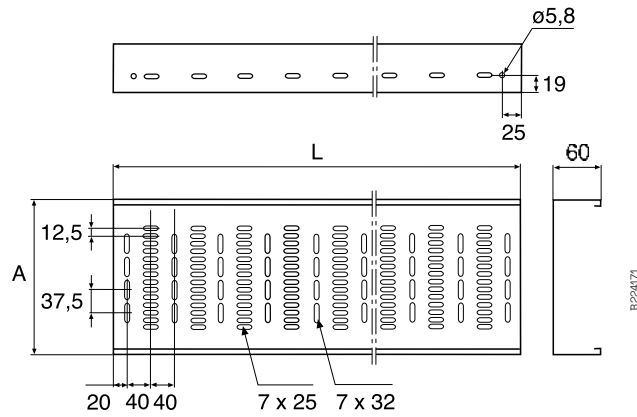

Cable tray W3 H=60 mm L=3000 mm

F1: End span, the joint position is in mid span

F2: Center span

One or more joints may be required dependent upon the product length and span.

Span 2 m

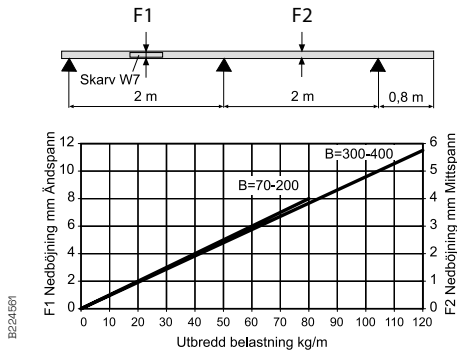

Type	A mm	L mm
Cable tray W3/60-70	70	3000
Cable tray W3/60-100	100	3000
Cable tray W3/60-150	150	3000
Cable tray W3/60-200	200	3000
Cable tray W3/60-300	300	3000
Cable tray W3/60-400	400	3000
Cable tray W3/60-500	500	3000
Cable tray W3/60-600	600	3000

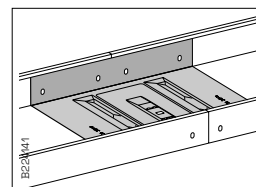
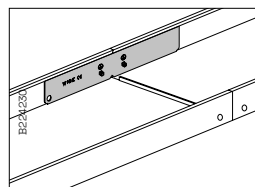

Cable tray W1/60 is joined with 2 Side joints W49/60 or Support bracket/joint W7/60.

For trays 300 mm and wider we recommend to use Support bracket/joint W7/60.

Technical information

Use and installation

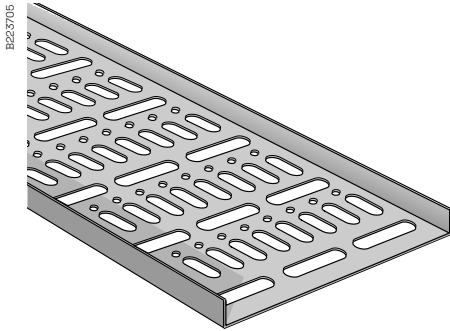

Installation tray W4

Perforated installation tray. To be used when leading cables down from a cable ladder to machine cabinets, etc. Provided with holes $\varnothing 3.5$ mm in the bottom segment of the tray for the clamping of cables with plate screws.

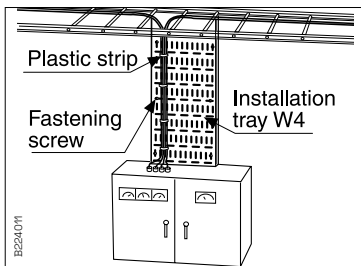
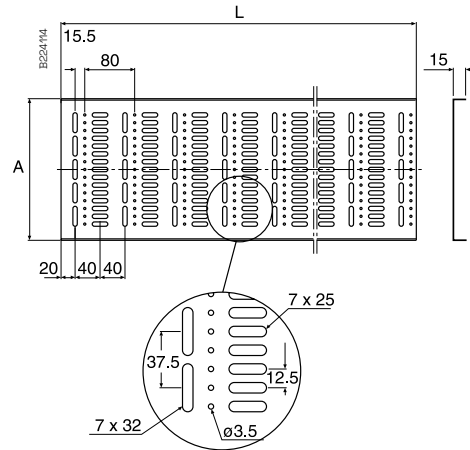

Type	L mm	A m
W4-50	1960	50
	3000	
W4-75	1960	75
	3000	
W4-100	1960	100
	3000	
W4-150	1960	150
	3000	
W4-200	1960	200
	3000	
W4-250	1960	250
	3000	
W4-300	1960	300
	3000	
W4-400	1960	400
	3000	

Technical information

Use and installation



P/65002

Lighting trunking W70

Cable tray with bottom perforation. System height 40 mm, length 3000 mm. Oval holes 9x6 mm on the lateral sides of the tray end can be used for fixation of joints. The oval hole pattern at the base of the tray can be used for mounting of lighting fixtures. On every 500 mm an oval hole is placed to easily guide fast connectors into the tray. In the wider trays with widths from 70 to 200 the hole is turned 45°.

Description	A mm
Lighting trunking W70-50	50
Lighting trunking W70-70	70
Lighting trunking W70-100	100
Lighting trunking W70-200	200

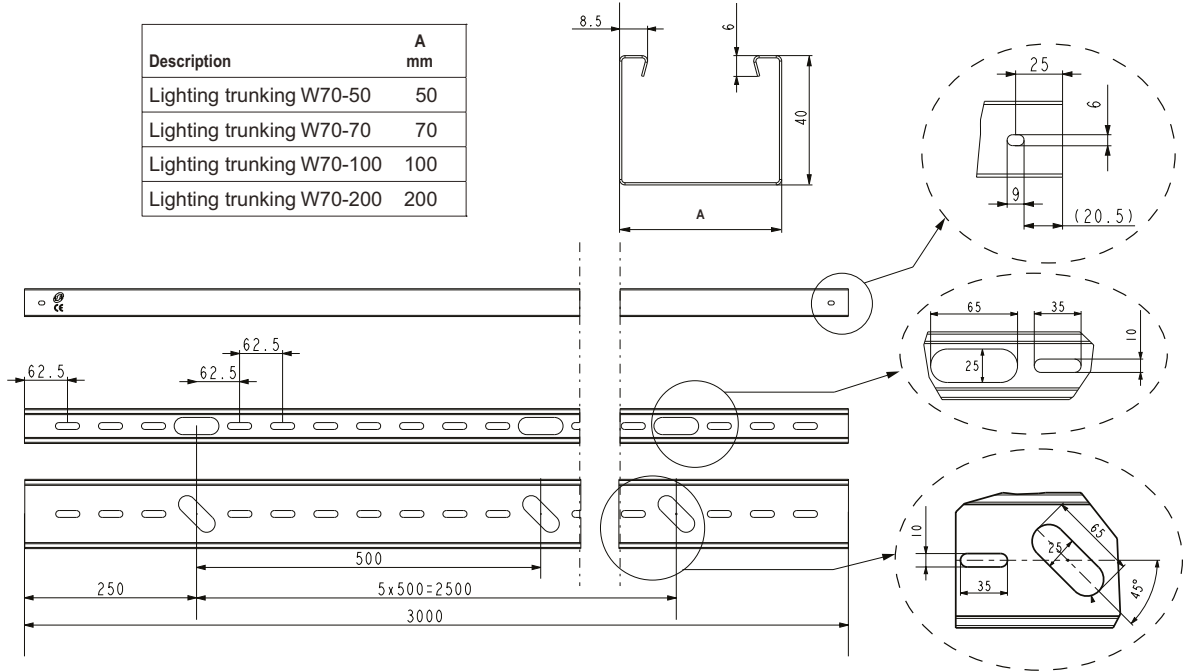

Loading capacity

Load test executed according to IEC 61537
 F1 represent deflection in section with joint
 F2 represent deflection in section without joint

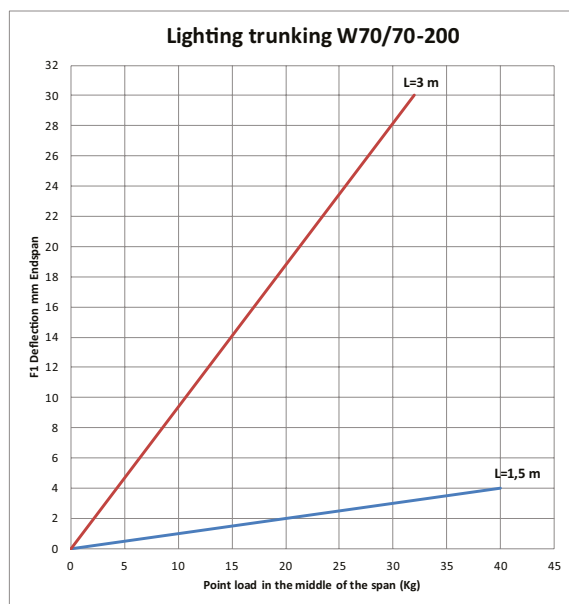
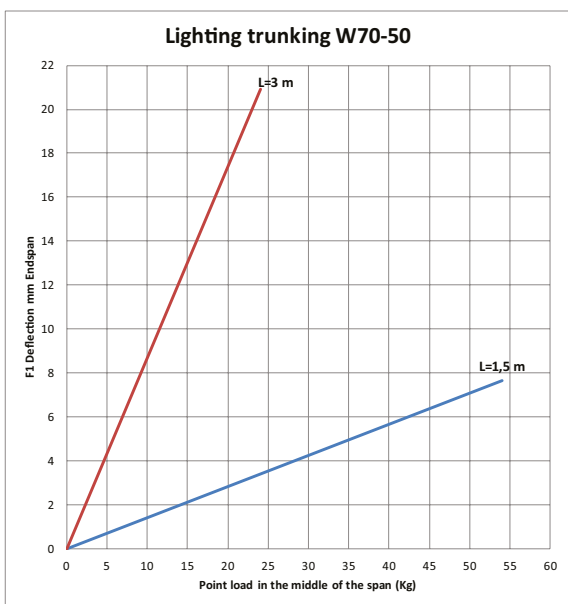
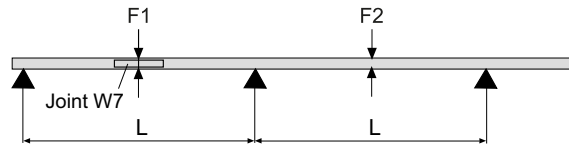

Breaking load for Joint W7/40-70 = 120 kg

Technical information

Use and installation

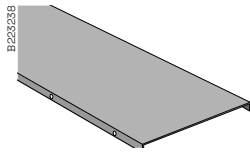

Cover W5

Cover to be used to protect the cables inside the cable tray against damages, dust, liquids, UV-influence, etc.

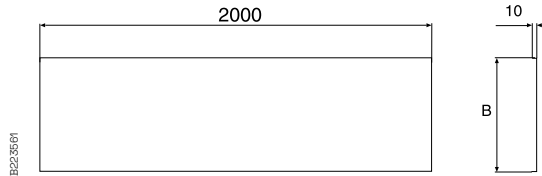

Type	B mm
Cover W5 - 70	71
Cover W5 - 100	101
Cover W5 - 150	151
Cover W5 - 200	201
Cover W5 - 300	301
Cover W5 - 400	401
Cover W5 - 500	501
Cover W5 - 600	601

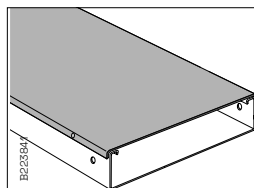

Used for screening of control cables and in dusty and dirty premises.

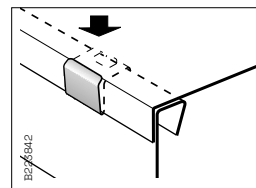

Covers must be mounted on cable trays with Cover clamp W62.

Cover clamp W62

Used for fixing covers on Trays W1 and W3 as well as on Lighting trunking W70.

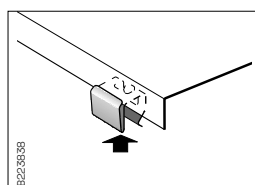
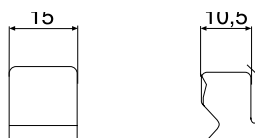
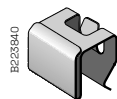

Cover clamp W62 is used for fixing the covers on Cable tray W1 and W3 as well as on Lighting trunking W70/71.

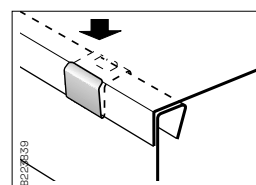

Start by pressing the Cover clamp W62 over the sides of the cover. Then snap the cover over the folded edges of the tray. 6 Cover clamps W62 are needed per cover.

Technical information

Use and installation - CLX³ Click suspension

P14B210

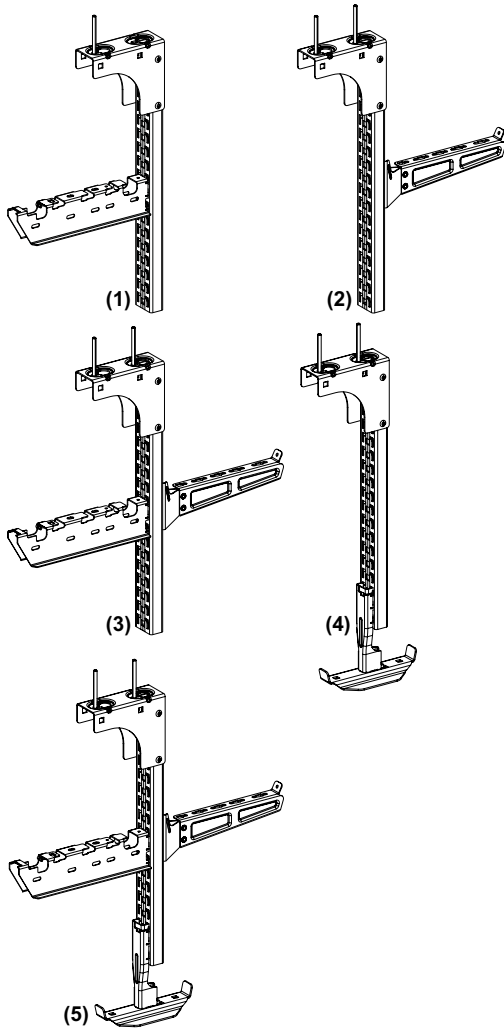

CLX³ General information

Standards

CLX³ installation system is tested and following the classification according to the IEC 61537.

Usage of gloves

According to IEC 61537 it is always recommended to use protective gloves when handling and manipulating cable support systems.

Handling and storage

- Store in dry and covered places.
- Avoid moisture and pollutants.
- Do not remove the packing until installation.
- Take care when storing and handling so that the CLX³ components are well protected from damage.

CLX³ Pendant loading configurations

CLX³ pendant is primarily designed for installation of the CLX³ support system, but can also be used for T-bolt installation.

The system can be installed in different configurations:

- b Click direction **(1)**: the cantilever and the ceiling plate are in the same direction
- b T-bolt direction **(2)**: a cantilever is fixed with a T-bolt to the rail, in the opposite direction of the ceiling plate
- b T installation **(3)**: combination of the first 2 installations
- b Central suspension **(4)**: the pendant is completed by a central suspension bracket
- b T and central suspension **(5)**.

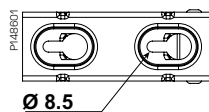

Fixation to the ceiling

Keyhole design

Keyhole design is facilitating easy mounting of the pendant to the ceiling by allowing the bolts to be pre-fixed before finally placing the pendant and tightening the bolts.

For concrete ceiling, use bolts type IMT38051.

For other bolts where bolthead is < 16 mm use washer u 16 mm.

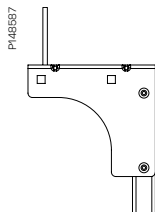

One bolt fixation

For click direction installation of CLX³ Cantilever arm **(1)**, use a single bolt, in the outer hole position on the ceiling plate.

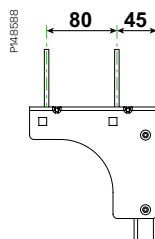

Two bolt fixation

For T-bolt suspension, central suspension, T installation and T and central suspension installation **(2)**, **(3)**, **(4)**, **(5)**, always fix the ceiling plate to the ceiling using 2 bolts.

Use the angle adaptor when the ceiling is not horizontal to level out the suspended pendant.

Technical information

Use and installation - CLX³ Click suspension

Pendant load calculation

To verify that the load applied to each pendant is within performance, it is necessary to calculate and consolidate the total **tensile load force** and the total **moment-force** on each pendant and for each cantilever and after that compare the calculated values with the defined loading limitations to ensure a safe installation.

Total tensile force Ft calculation method

This is calculated as the sum of all forces applied to the pendant from the weight of cables on the length material.

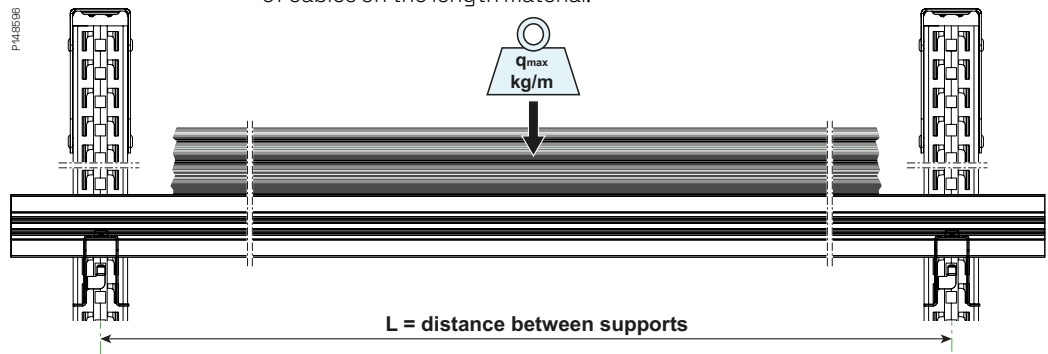

$$F_t \text{ (total load in N)} = L \text{ (span or supports distance in meters)} \times q_{max} \text{ (load in kg/m)} \times 10.$$

In case of several layers are installed on the pendant then the sum of the Ft tensile load from all layers shall be calculated.

Total momentum force Mt calculation method

This is calculated as the sum of all the torsion forces applied to the pendant from the weight of cables on the length material and the offset distance created by the cantilever arm.

$$M_t \text{ (momentum in N.m)} = F_t \text{ (N)} \times d \text{ (distance between axis center and point load in meters)}$$

“d” depends of the position of the length material on the cantilever arm.

The distance **d** can be different depending on installation method.

When the length material is installed on the full width of the cantilever, use **d1**.
For length material that are installed at the outer end of the arm, use **d2**.

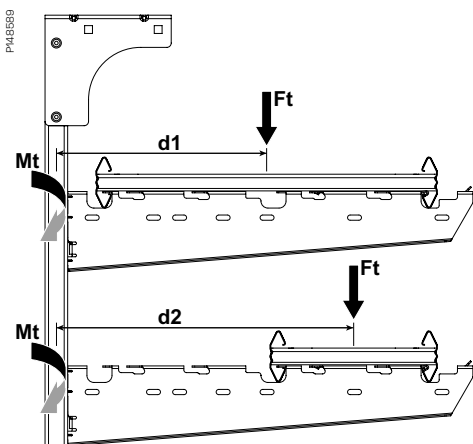

Model	PG	d1 (m)	d2 (m)
CLX ³ cantilever arm 100	CSU795645	0.09	Na
CLX ³ cantilever arm 150	CSU795646	0.110	
CLX ³ cantilever arm 200	CSU795647	0.140	
CLX ³ cantilever arm 300	CSU795648	0.190	0.340
CLX ³ cantilever arm 400	CSU795649	0.240	
CLX ³ cantilever arm 500	CSU795650	0.290	
CLX ³ cantilever arm 600	CSU795651	0.340	

In case of several layers are installed on the pendant then the sum of the Mt momentum force from all layers shall be calculated.



Ensure that the installation is designed so that ΣM_t and ΣF_t are under the limits.

Technical information

Use and installation - CLX³ Click suspension

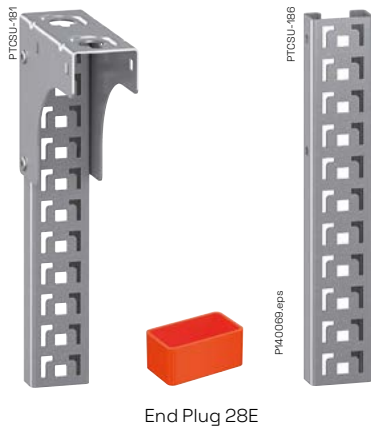

End Plug 28E

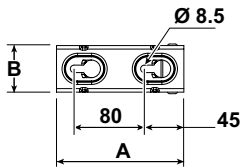
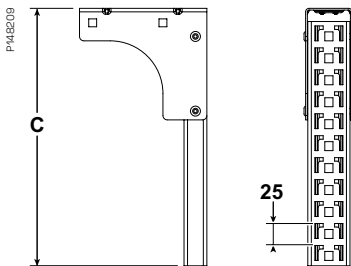
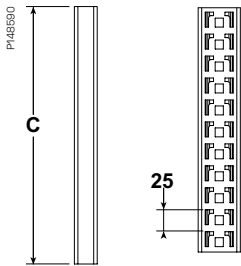

CLX³ Pendant 24/48

Vertical piece with a perforated pattern to be used for installation of CLX³ cantilever arms or CLX³ central suspension adapter. The open side of the rail can be used for installation of cantilever arms and brackets together with T-bolt. Can be joined to CLX³ Rail 24/48 with pendant joint 2FJ.

Model	PG	High (mm) A	Width (mm) B	Length (mm) C
CLX³ pendant				
CLX ³ pendant 24/48 300 mm PG	CSU795632	145	53	295
CLX ³ pendant 24/48 400 mm PG	CSU795633			395
CLX ³ pendant 24/48 500 mm PG	CSU795634			495
CLX ³ pendant 24/48 700 mm PG	CSU795635			695
CLX ³ pendant 24/48 1000 mm PG	CSU795636			995
CLX ³ pendant 24/48 1500 mm PG	CSU795638			1495
CLX³ rail				
CLX ³ rail 24/48 300 mm PG	CSU795640	26	48	280
CLX ³ rail 24/48 1000 mm PG	CSU795641			980
CLX ³ rail 24/48 3000 mm PG	CSU795637			2980

Pendants Safe Working Load (SWL)

SWL for bending moment of the pendant **Mt**.

Model	PG	Moment (N.m) Click side	Deflection (mm)
CLX ³ pendant 24/48 300 mm PG	CSU795632	235	2
CLX ³ pendant 24/48 400 mm PG	CSU795633		4
CLX ³ pendant 24/48 500 mm PG	CSU795634		7
CLX ³ pendant 24/48 700 mm PG	CSU795635		15
CLX ³ pendant 24/48 1000 mm PG	CSU795636		30
CLX ³ pendant 24/48 1500 mm PG	CSU795638		200

Tested according to IEC 61537 standard.

SWL bending moment for Adjustable ceiling plate **Mt**.

Model	PG	Moment (N.m) Click side
CLX ³ adjustable ceiling plate	CSU795639	235

SWL pendant tensile strength **Ft**.

Model	PG	Tensile load SWL (N) 1 bolt CLX ³	Tensile load SWL (N) 2 bolts CLX ³
CLX ³ pendant 24/48 300 mm PG	CSU795632	2000	5000
CLX ³ pendant 24/48 400 mm PG	CSU795633		
CLX ³ pendant 24/48 500 mm PG	CSU795634		
CLX ³ pendant 24/48 700 mm PG	CSU795635		
CLX ³ pendant 24/48 1000 mm PG	CSU795636		
CLX ³ pendant 24/48 1500 mm PG	CSU795638		

Technical information

Use and installation - CLX³ Click suspension

Pendant limits, torque and deflection

In the diagram below it is possible to check if ΣMt is below the momentum limitation of the pendant (end of line). It is also possible to see the deflection on the pendant at max ΣMt and all values below.

Calculation example

For a cantilever size 600, full size ladder installation, 3 m span, load of 23 kg/m on a 1000 mm pendant.

1) ΣF : 3 m (span) x 23 kg/m (load) x 10 = 690 N will be the load for each pendant system.

2) ΣMt : 690 (N) x 0.34 (m) = 234 N.m.

ΣF = 690 N \leq 2000 N and ΣMt = 234 Nm \leq 235 N.m.

3) Drawing of the lines on the graph: for 234 N.m, the deflexion on the pendant is **30 mm**.

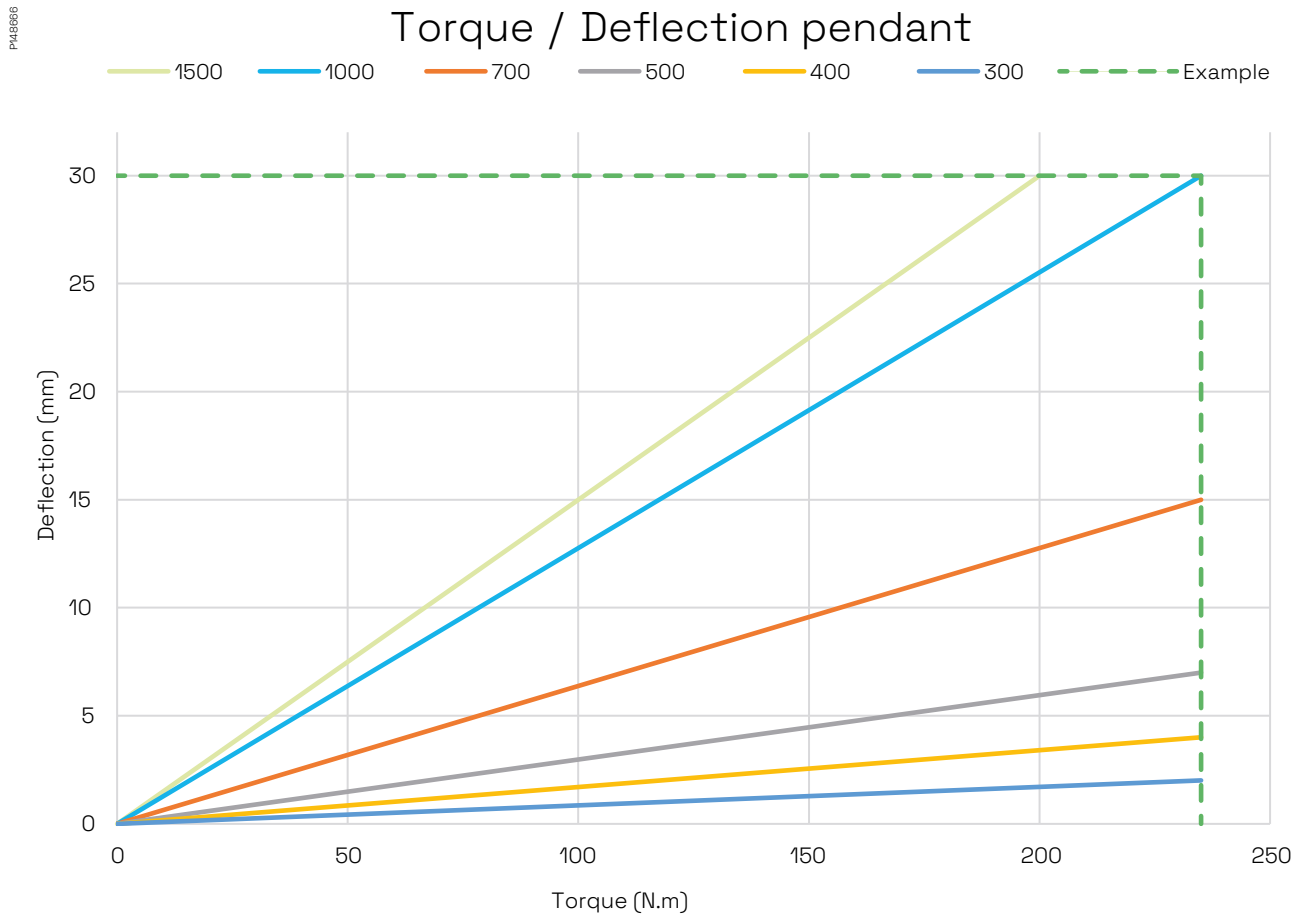

Technical information

Use and installation - CLX³ Click suspension

Distance between rails and offset

CLX³ rail have a pitch between the patterns of 25 mm.

The support distance between the pendants should be at least than 1.5 m. If the length material can't be installed on the exact same level, the length material should be installed on the closest offset- pitch and never at more than 12.5 mm vertically from the previous pattern.

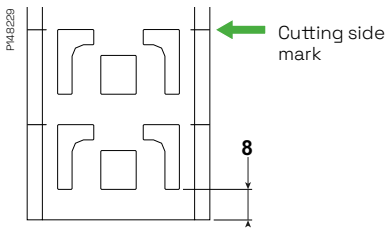
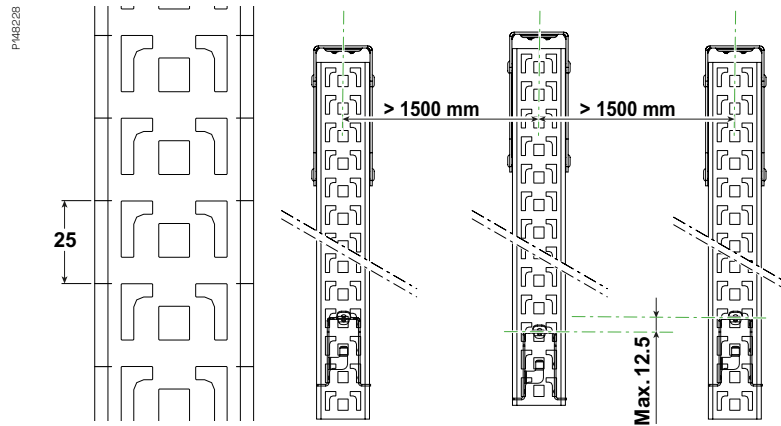

Cutting of the pendant or rail

Cutting of the rail or the pendant should be made at 8 mm under the last pattern needed, as the side marks are showing. This to assure that there is enough material below the bottom pattern to secure proper fixation of the cantilever arm.

Installation of the rail joint

CLX³ rails can be joined together with pendant joint 2FJ.

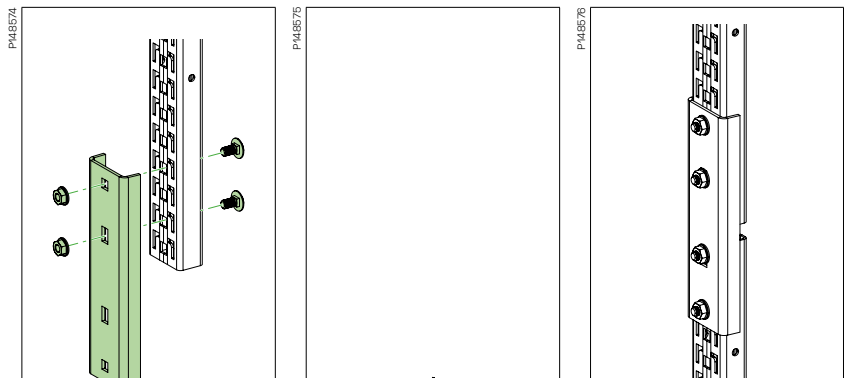

Place the joint on the rail in place, make sure the 2 top holes are in front of slots to install the included bolts and nuts.

Install the second rail as high as possible and install the other bolts and nuts.

Torque of the nuts **11 N.m.**

Note: extending the pendant with the rail joint will decrease the load capacity of the pendant. For SWL information when extending the pendants, contact Technical support.

Technical information

Use and installation - CLX³ Click suspension

PTCSUJ-87



CLX³ Adjustable ceiling plate

Adjustable ceiling plate is used together with CLX³ pendant to allow for angle correction up to 25°. The adjustable ceiling plate is fixed to the CLX³ pendant with 4 screw set 22S to be ordered separately. The pendant can be fixed to the adjustable ceiling plate in both possible directions (1) and (2).

Model	PG	High (mm) A	Width (mm) B	Length (mm) C
CLX ³ adjustable ceiling plate PG	CSU795639	100	59	150

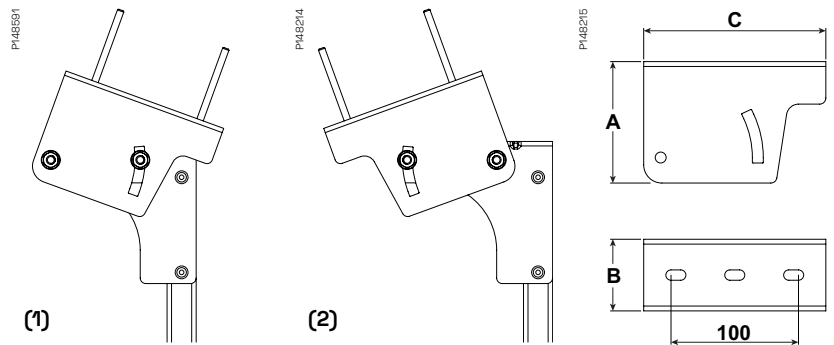

Installation of the adjustable ceiling plate

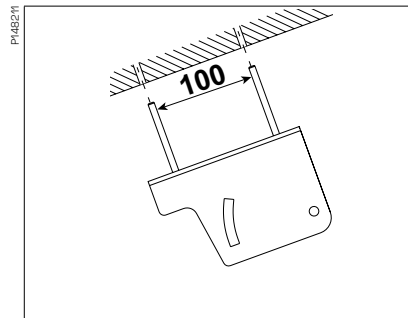

Fix the adjustable ceiling plate to the ceiling with 2 bolts. (c-c: 100 mm).

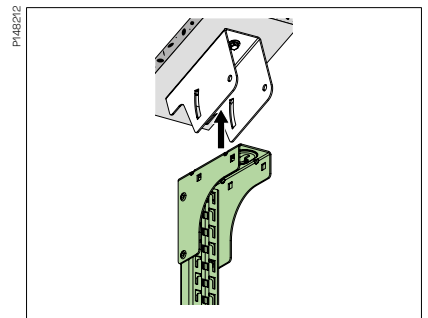

Insert the pendant into the adjustable ceiling plate.

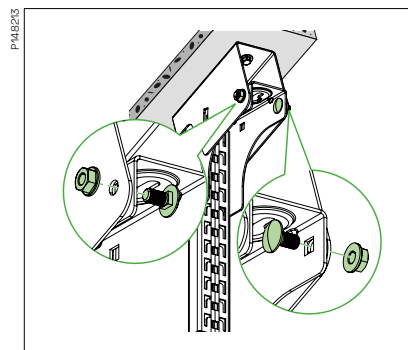

Fix the pendant to the adjustable ceiling plate with 4 bolt sets 22S and align the pendant to the vertical plane before tightening the bolts.

Recommended torque 20 N.m.

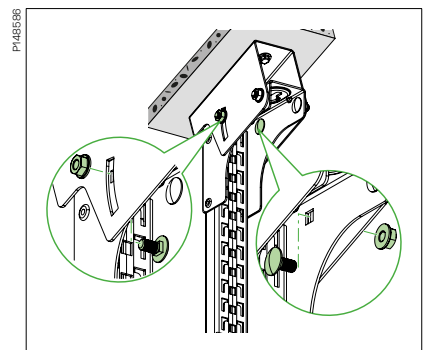

Technical information

Use and installation - CLX³ Click suspension

P7CSU-190



CLX³ Central suspension adapter

The CLX³ central suspension adapter is clicked together with the central suspension brackets to create a central suspension piece that can be clicked to the rail or pendant.

Model	PG	High (mm) A	Width (mm) B	Length (mm) C
CLX ³ Central suspension adapter PG	CSU795700	166	31	39

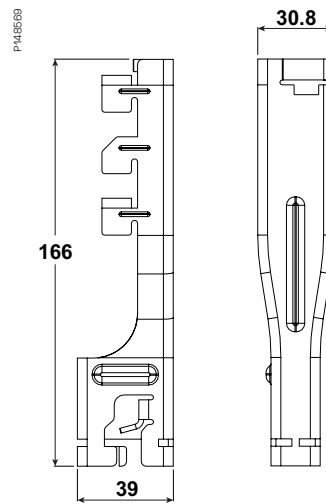

Technical information

Use and installation - CLX³ Click suspension



CLX³ Cable tray H40 central suspension

Bracket to be used for central suspension of Wibe cable trays, height 40. The bracket shall be used together with the CLX³ central suspension adapter.

Model	PG	High mm A	Width mm B	Length mm C
CLX ³ Tray H40 central suspension 70 PG	CSU795653	152	37	66
CLX ³ Tray H40 central suspension 100 PG	CSU795654	152	37	96

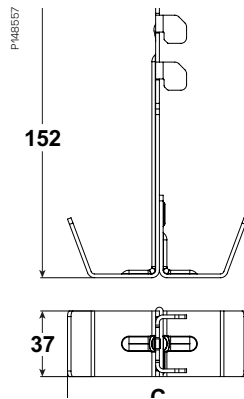

Model	PG	High mm A	Width mm B	Length mm C
CLX ³ Tray H40 central suspension bracket 200 PG	CSU795660	36	76	196
CLX ³ Tray H40 central suspension bracket 300 PG	CSU795661	36	76	296
CLX ³ Tray H40 central suspension bracket 400 PG	CSU795662	36	76	396
CLX ³ Tray H40 central suspension bracket 500 PG	CSU795663	36	76	496
CLX ³ Tray H40 central suspension bracket 600 PG	CSU795664	36	76	596

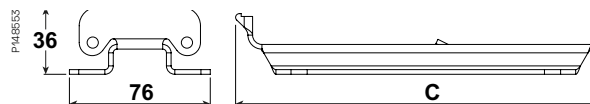

Tray H40 central suspension bracket	SWL symmetric load (N)
70	1000
100	800
200	1500
300	1500
400	1500
500	1250
600	1200

Technical information

Use and installation - CLX³ Click suspension

Installation of adaptor to central suspension brackets

The CLX³ central suspension bracket is installed without tools by clicking it to the central suspension. The method is the same for Central suspension bracket ladder -mesh or -tray. In the illustration below, the CSB for ladder is used.

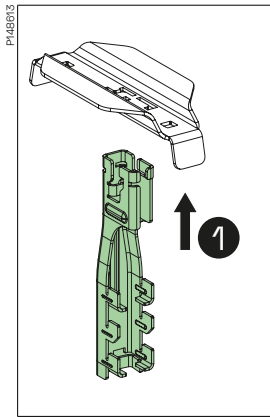
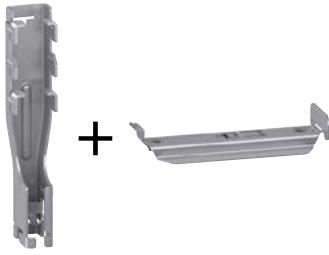

1 Insert the adaptor in the pattern on the central suspension bracket.

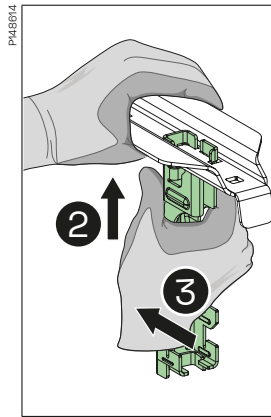

2 Press the pieces together and **3** slide the adaptor until the click lip of the adaptor pass over the locking lip of the central suspension bracket with a **4** click.

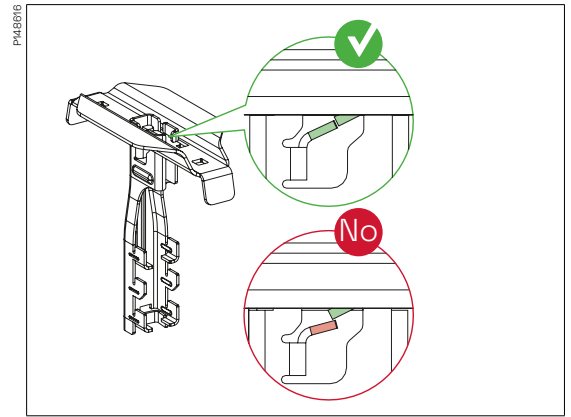
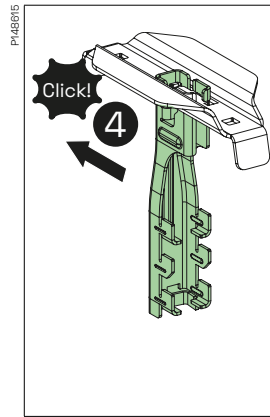

Visually check and secure that the adaptor is properly positioned, and the click lip has overpassed the locking lip.

Installation of central suspension adaptors to the CLX³ rail

The CLX³ central suspension adaptors is installed to the rail without tools, by clicking. To ensure proper installation a hooks must be inserted in the rail:

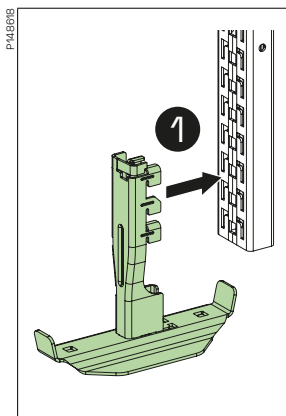

1 Push the central suspension piece until the hooks are fully inserted in the pattern and the surface touches the rail.

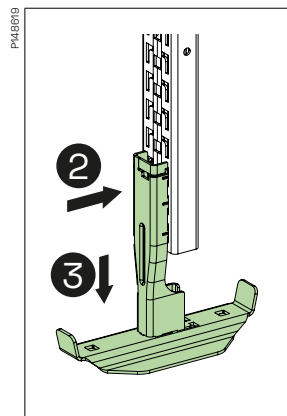

2 Press towards the rail and **3** pull down until the click lip.

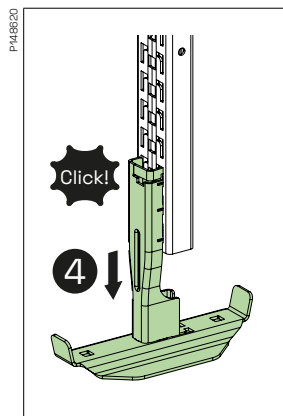

4 Pass inside the slot in the rail.

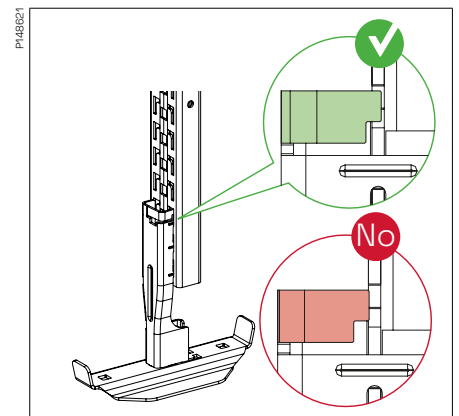

Visually check and secure that the adaptor is properly positioned, and the click lip is properly positioned inside of the slot of the CLX³ rail.



Apply caution with unintended upward movements as it can cause the adaptor to unlock and therefore be released from the rail

Technical information

Use and installation - CLX³ Click suspension

Uninstallation of adapter from the CLX³ rail

CLX³ central suspension adapters can be removed, by using a flat screwdriver.

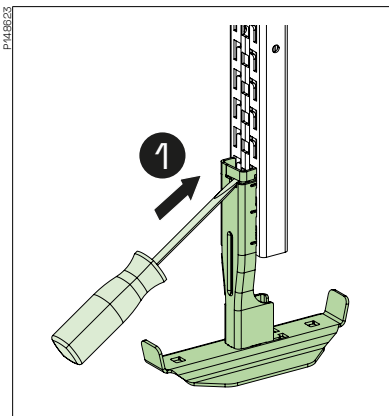

1 Fit the screwdriver's head in the slot of the adaptor.

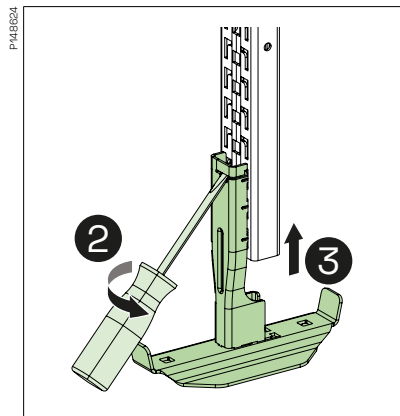

Use the screwdriver as a lever to **2** gently release the click lip from the rail. Then **3** push the adaptor up to release the L hooks from the rail.

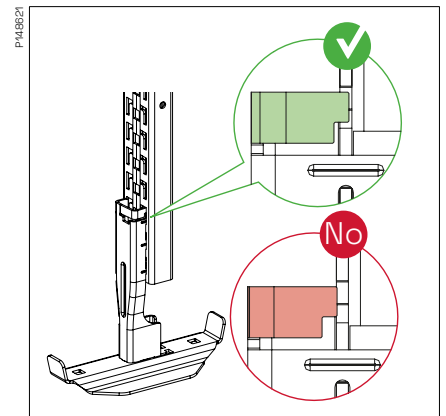

If the adapter needs to be reinstalled, correct the click lip to the initial position and make sure the click lip is locking properly.

Uninstallation of adaptor from central suspension brackets

CLX³ central suspension brackets can be removed, by using a flat screwdriver.

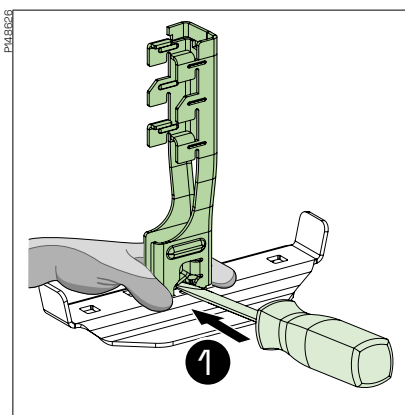

1 Hold the bracket, fit the screwdriver's head between the adaptor lip and the bracket.

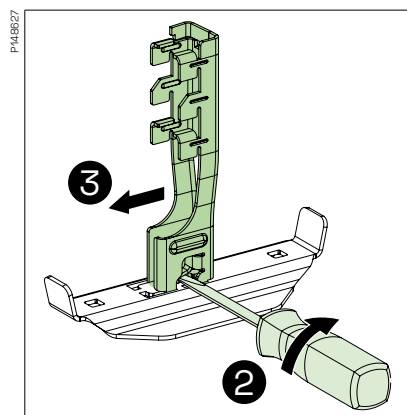

2 Twist the screwdriver to use it as a lever on the click lip until it passes over the bracket's locking lip and **3** pull the adaptor sideways to release it.

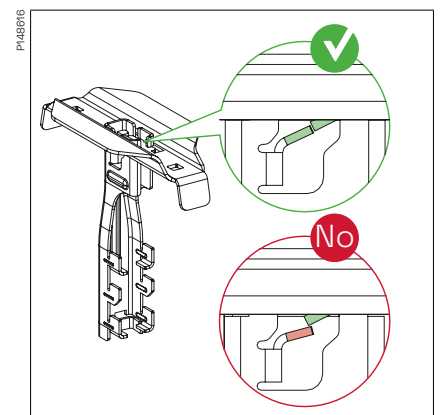

When the bracket needs to be reinstalled, correct the click lip to the initial position and make sure the click lip is locking properly.

Technical information

Use and installation - CLX³ Click suspension



Installation of Wibe H40 cable trays on central suspension bracket

CLX³ central suspension bracket for Wibe cable tray H40, 70 and 100 width is installed to the rail without tools, by clicking.

1 Press the piece until the hooks are fully inserted in the pattern and the surface touches the rail.

2 Press towards the rail and **3** pull down until the click lip.

4 Pass inside the slot in the rail.

Visually check and secure that the bracket is properly positioned, and the click lip is positioned inside the slot in the CLX³ rail.



Apply caution with unintended upward movements as it can cause the bracket to unlock and therefore be released from the rail

Uninstallation of Wibe H40 central suspension bracket from the CLX³ rail

CLX³ central suspension brackets can be removed, by using a flat screwdriver.

1 Fit the head of screwdriver on the side of the locking lip.

2 Use the screwdriver as a lever to gently bend the lip. **3** Push the bracket upwards.

When the bracket needs to be reinstalled, correct the click lip to the initial position and make sure the click lip is locking properly.

Technical information

Use and installation - CLX³ Click suspension

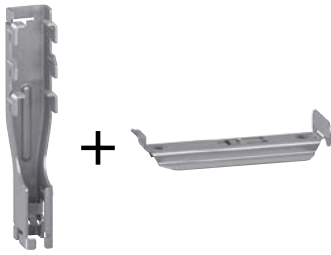

Installation of Wibe H40 cable trays on central suspension bracket

CLX³ brackets are made to fix Wibe cable trays without tool.

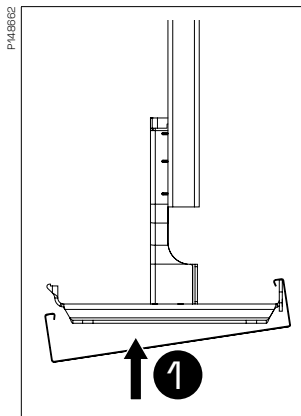

1 Insert one flange of the tray on the flat lip of the bracket.

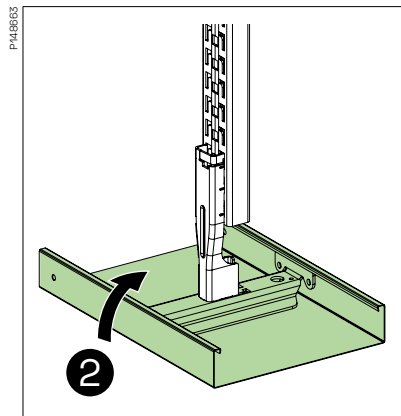

Pull up the other side and **2** snap the tray on the other lip.

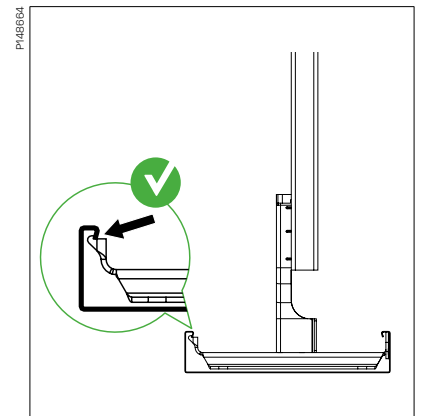

For safety, check if the tray is secured inside the bracket lips.



Apply caution with unintended upward movements as it can cause the tray to unlock and therefore be released from the bracket

Uninstallation of Wibe H40 cable tray from central suspension bracket

Wibe cable trays can be remove from the bracket.

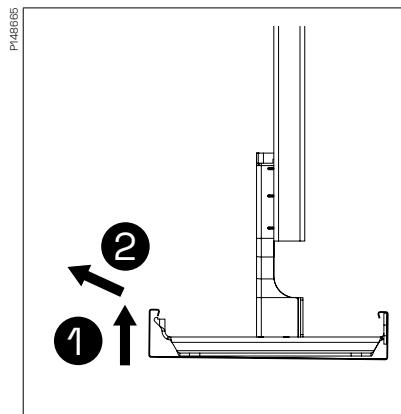

1 Push the cable tray up on the claw side. **2** Pull the cable tray lip out of the bracket.

Technical information

Use and installation

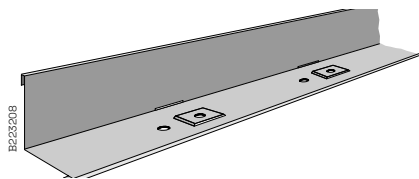

Dividing strip 39

Dividing strip to be used to separate low-tension and high-tension cables.

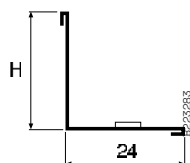
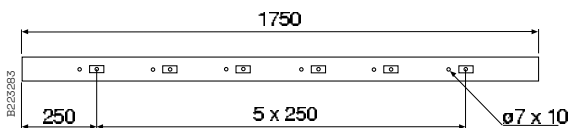

Type	H mm
Dividing strip 39/24	24
Dividing strip 39/55	55

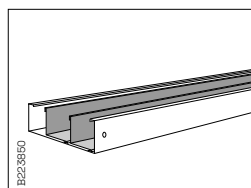

Used to separate tray or trunking in two or more ducts thereby separating control cables from other cables and pipes. The hole structure at distances of 250 mm permits two fixing opportunities with Support bands W6 even after cutting.

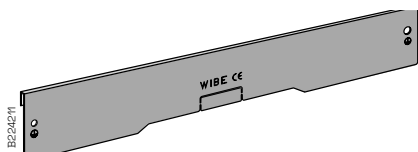

Insert piece W39/55

Insert piece to be used to join Dividing strips 39/55 in Cable trays W1/60 or W3/60. The insert piece can be positioned on Support bracket/joint W7/60 to ensure a continuous separation of cables inside the cable tray.

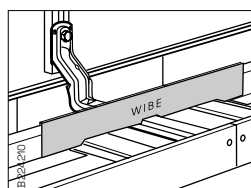
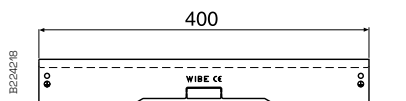

Insert piece W39/55 is used to join Dividing strips 39/55 and is mounted on Support bracket/joint W7/60.

Technical information

Use and installation

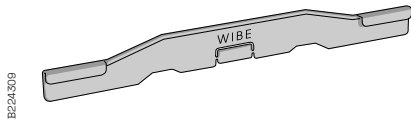

Insert piece W39

Insert piece to be used to join Dividing strips 39/24 in cable tray W1/W3 and lighting trunking W70/71. The Insert piece can be positioned on Support bracket/joint W7/40 to ensure a continuous separation of cables inside the cable tray.

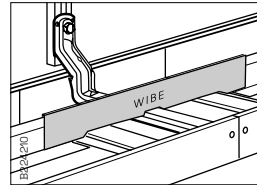
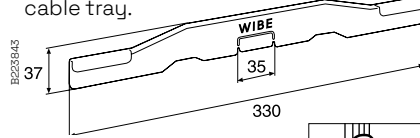

Insert piece W39 is used to join Dividing strips W39 and is mounted on Support bracket/joint W7 or Internal cantilever arm W17/40. When mounting over Internal cantilever arm W17/40, break away plastic bit from component.

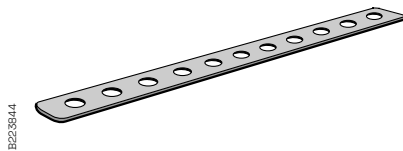

Support band W6

Support band to be placed inside cable trays to fix the lateral position of one or several Dividing strips W39. The holes in the support band and the locking pins in Dividing strip W39 enable an adjustment of the lateral positioning of the dividing strip with an interval of 25 mm.

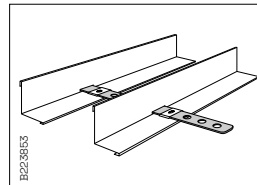
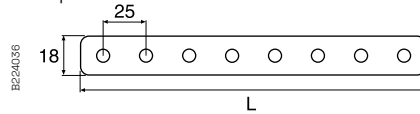

Support band W6 is mounted to fix one or more Dividing strips 39 laterally. The holes in the support band and the locking pins in Dividing strip 39 allow for a fixed division with intervals of 25 mm.

Type	L mm
Support band W6-70	67
Support band W6-100	97
Support band W6-200	197
Support band W6-300	297
Support band W6-400	397
Support band W6-500	497
Support band W6-600	597

Technical information

Use and installation

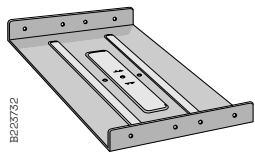

W7/40-
70,100,200,300,400

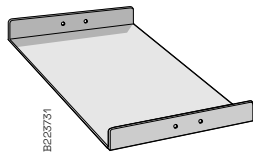

W7/40-
50,150,500,600

Support bracket/joint W7/40

To be used as a support bracket or joint for cable tray W1/40, W3/40 and for lighting trunking W70. When joining cable tray W1/40 FS (reinforced), side joint W49/40 must be used.

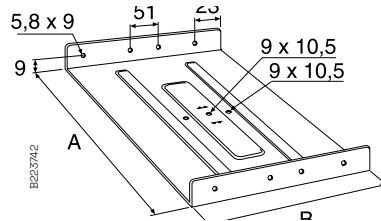

Type	A mm	B mm
Support bracket/joint W7/40-50	48	200
Support bracket/joint W7/40-70	68	200
Support bracket/joint W7/40-100	98	200
Support bracket/joint W7/40-150	148	200
Support bracket/joint W7/40-200	198	200
Support bracket/joint W7/40-300	297	300
Support bracket/joint W7/40-400	397	300
Support bracket/joint W7/40-500	498	300
Support bracket/joint W7/40-600	598	300

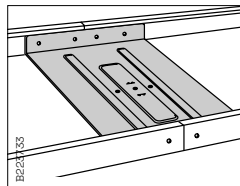

Support bracket/joint W7/40 is used for straight joining. Push-in mounting. See also Joint W7/40 HDG, p.101, used for joining of Hot dip galvanized trays.

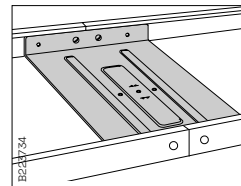

If necessary trays and lighting trunkings are locked using Screw set W38P or Locking plug W41.

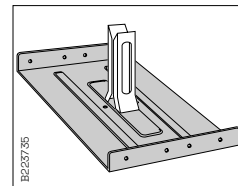

With Pendant attachment W21 installed on Support bracket/joint W7/40-100, 200, 300 or 400 a complete support bracket is obtained.

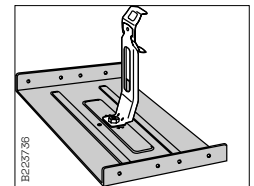

Tube pendant attachment W73 or the one half of Pendant attachment W21 are mounted on Support bracket/joint W7/40-70, 100, 200, 300 or 400 with Screw set W36/W36C.

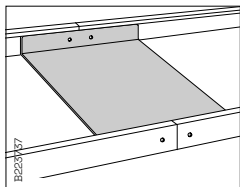

W7/40-50, 150, 500 and 600 are only used for joining, not as support brackets. Reinforced tray is to be joined with Side joint W49/40.

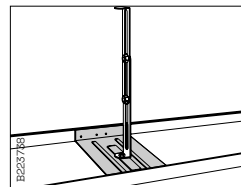

End bracket WN17 can be used as vertical piece on Support bracket/joint W7/40, mounted with Screw set W36/W36C.

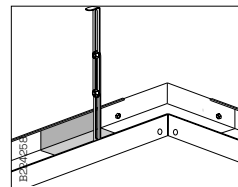

Support bracket/joint W7/40 is used to achieve an invisible suspension in or in connection with bends or junctions, here with End bracket WN17 mounted as vertical piece.

Technical information

Use and installation

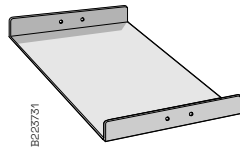

Joint W7/40 HDG

Used as a joint for Hot dip galvanized Cable trays W3/40 and Lighting trunkings W70.

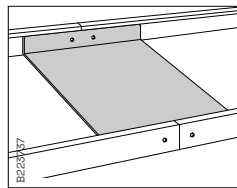
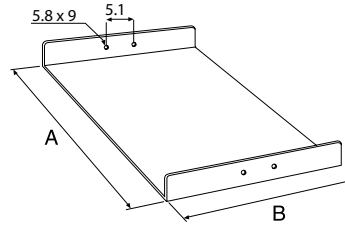

Joint W7/40 Hdg is only used for joining, not as support bracket. If necessary trays are locked using Screw set W38P or Locking plug W41

Technical information

Use and installation

Support bracket/joint W7/60

To be used as a support bracket or joint for cable tray W1/60, W3/60. When joining cable tray W1/60 FS (reinforced), side joint W49/60 must be used.

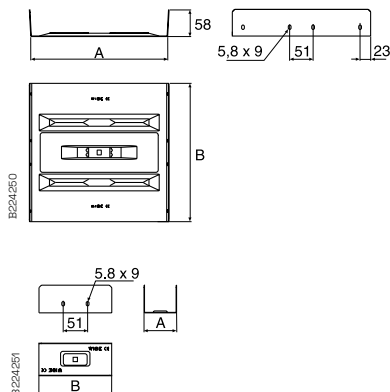
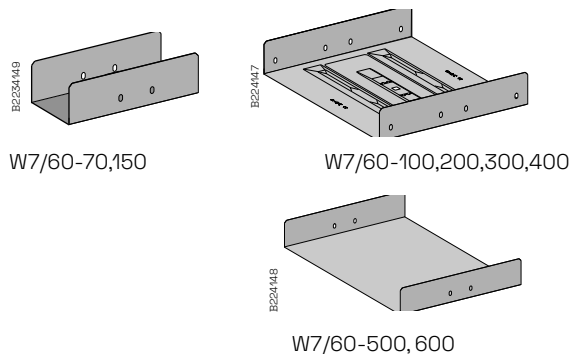

Type	A mm	B mm
Support bracket/joint W7/60-70	68	152
Support bracket/joint W7/60-100	98	200
Support bracket/joint W7/60-150	148	200
Support bracket/joint W7/60-200	198	200
Support bracket/joint W7/60-300	297	300
Support bracket/joint W7/60-400	397	300
Joint W7/60-500	498	300
Joint W7/60-600	598	300

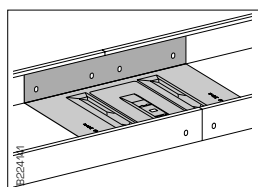

Support bracket/joint W7/60 is used for straight joining. Push-in mounting.

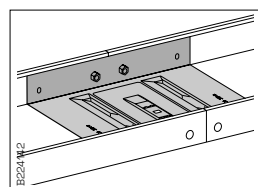

If necessary trays are locked using Screw set W38P or Locking plug W41.

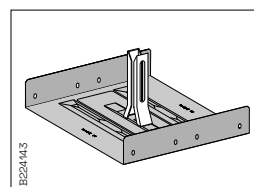

With Pendant attachment W21 installed, a complete support bracket is obtained. Does not apply to W7/60-70, 150, 500 and 600.

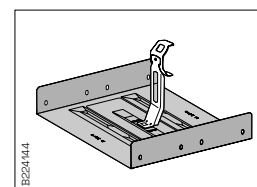

Tube pendant attachment W73 or one half of Pendant attachment W21 are mounted with Screw set W36/W36C. Does not apply to W7/60-500 and 600.

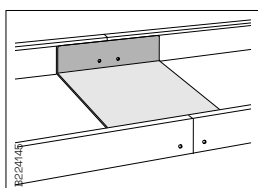

W7/60-500 och 600 are only used for joining, not as support brackets. Reinforced tray is to be joined with Side joint W49/60.

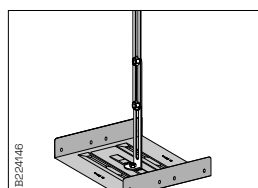

End bracket WN17 can be used as vertical piece on Support bracket/joint W7/60 mounted with Screw set W36/W36C.

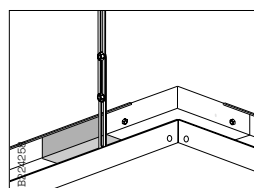

Support bracket/joint W7/60 is used to achieve an invisible suspension in or in connection with bends or junctions, here with End bracket WN17 mounted as vertical piece.

Technical information

Use and installation

Support bracket W20

Support bracket to be used for invisible installation of lighting trunking W70/71, width 70 and 100 mm. The support bracket is snapped firmly into the trunking. Two nuts M10 are included. Suitable for threaded rod W76 M10.



W20-70

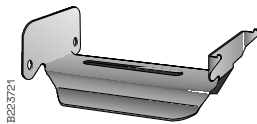

W20-100

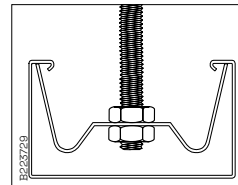
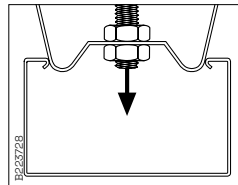

Lightly press down Support bracket W20-70 into Lighting trunking W70-70.

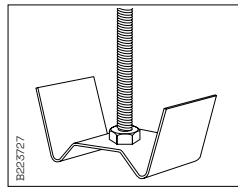

Mount Support bracket W20-70 onto Threaded rod W76 M10 with 2 M10 nuts.

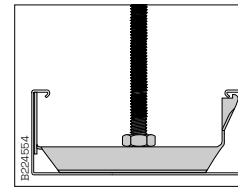

Support bracket W20-100 is mounted onto Threaded rod W76 M10 with 2 M10 nuts.

Support bracket W20A

Support bracket to be used for invisible installation of lighting trunking W70/71, width 70 and 100 mm. The support bracket is snapped firmly into the trunking. The spring locking device facilitates easy vertical height adjustment. Suitable for threaded rod W76 M10.

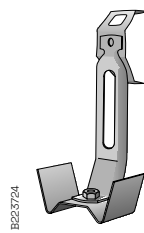

W20A-70

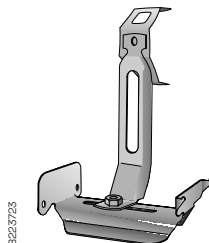

W20A-100

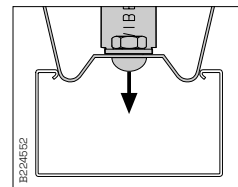
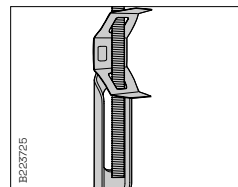

Support brackets W20A-70 and W20A-100 are mounted on Threaded rod W76 M10. This enables simple vertical adjustment of +30 mm.

Lightly press down Support bracket W20A-70 into Lighting trunking W70-70.

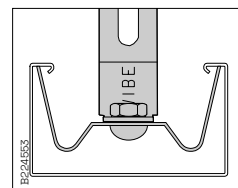
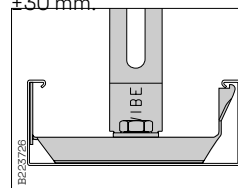

Support bracket W20A-100 is easily snapped firmly into Lighting trunking W70-100.

Technical information

Use and installation

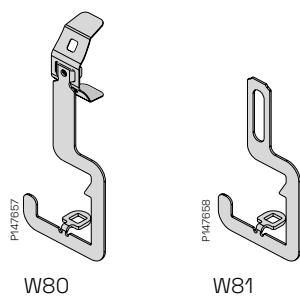

W80

W81

Pendant bracket W80/W81

Pendant bracket to be used to support lighting trunking W70-50. W80 pendant bracket facilitates easy vertical height adjustment on threaded rod. W81 needs to be suspended with Pendant rail W32.

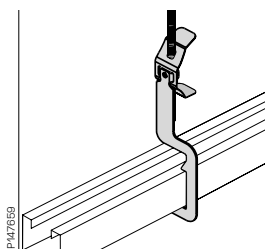
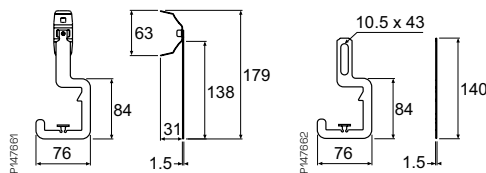

Pendant bracket W80 mounted under Lighting trunking W70-50 and attached with Screw set W36/W36C. Threaded rod W76 M6 is easily mounted in the spring clasp without bolts. Adjustable to ± 30 mm.

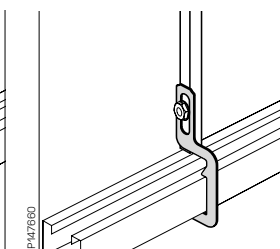

Pendant bracket W81 is mounted under Lighting trunking W70-50 and is attached with Screw set W36/W36C. Pendant rail W32 is mounted using Screw set W37. Adjustable to ± 18 mm.

Technical information

Use and installation

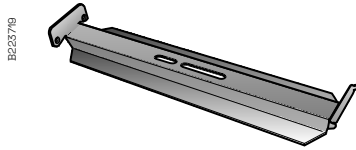

Support bracket W1940

Support bracket to be used for invisible installation of cable trays W1/40 and W3/40.

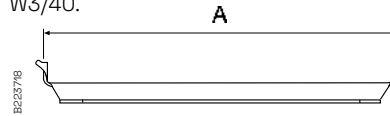

Type	A mm
Support bracket W1940-100	90
Support bracket W1940-200	190
Support bracket W1940-300	289
Support bracket W1940-400	389
Support bracket W1940-500	489
Support bracket W1940-600	589

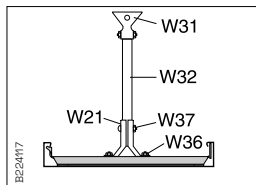

Tray W1/40 and W3/40, widths 200 to 400, are mounted with suitable Support bracket W1940, Pendant rail W32, Pendant attachment W21, Screw sets W37 and W36/W36C. Trays with width 100 can be mounted with Support bracket W1940-100, one half of Pendant attachment W21 or Tube pendant attachment W73 and Screw set W36/W36C.

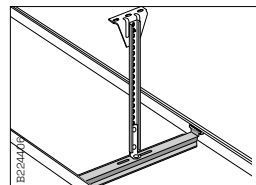

Support bracket W1940 mounted with Ceiling bracket 5, Pendant/ Fixing rail 24/34 and Angle bracket W8S. Screw set 22S must be used. For cable tray widths 500 and 600.

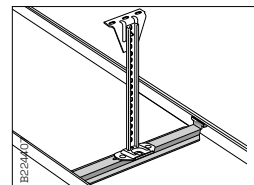

Support bracket W1940 mounted on Vertical piece 2 and Ceiling bracket 5. Screw set 22S must be used. For cable tray widths 500 och 600.

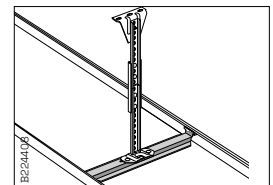

Support bracket W1940 can be mounted with Vertical piece 2, Pendant joint 2J, Pendant/ Fixing rail 24/34 and Ceiling bracket 5. Screw set 22S must be used. For cable tray widths 500 and 600.

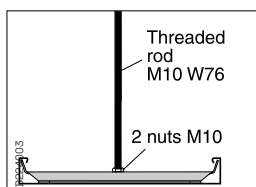

Alternatively, Tray W1/40 and W3/40 with widths 500 and 600 can be installed with suitable Support bracket W1940, Threaded rod W76 M10 and 2 M10 nuts.

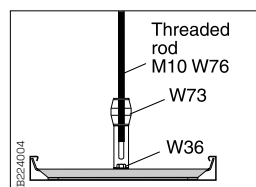

Alternatively, Tray W1/40 and W3/40 with widths 500 and 600 can be installed with suitable Support bracket W1940, Threaded rod W76 M10 and Tube pendant attachment W73.

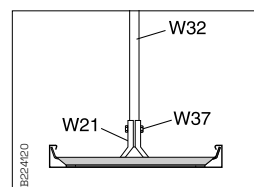

Alternatively, Tray W1/40 and W3/40 with widths 500 and 600 can be installed with suitable Support bracket W1940, Pendant rail W32, Pendant attachment W21 and Screw set W37.

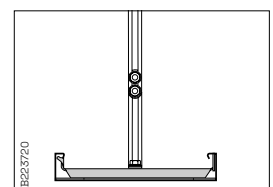

Tray W1/40 and W3/40 can be mounted on suitable Support bracket W1940 and 2 End bracket WN17 as pendant. The end brackets are joined with 2 Screw sets 22S and can be adjusted in height. The pendant can be mounted in the support bracket with Screw set W36/ W36C.

Technical information

Use and installation

B224286

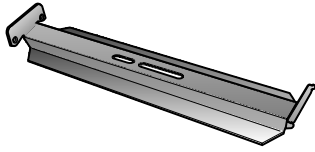

Support bracket W1960

Support bracket to be used for invisible installation of cable trays W1/60 and W3/60.

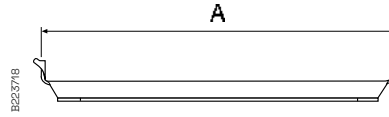

Type	A mm
Support bracket W1960-100	89
Support bracket W1960-200	189
Support bracket W1960-300	289
Support bracket W1960-400	389
Support bracket W1960-500	489
Support bracket W1960-600	589

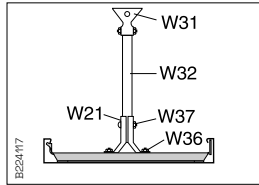

Tray W1/60 and W3/60, widths 200 to 400, are mounted with suitable Support bracket W1960 and Pendant rail W32, Pendant attachment W21 and Screw set W37. Trays with width 100 can be mounted with Support bracket W1960-100, one half of Pendant attachment W21 or Tube pendant attachment W73 and Screw set W36/W36C.

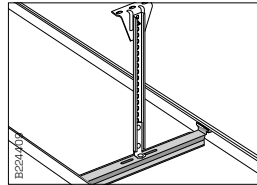

Support bracket W1960 mounted with Ceiling bracket 5, Pendant/ Fixing rail 24/34 and Angle bracket W8S. Screw set 22S must be used. For cable tray widths 500 and 600.

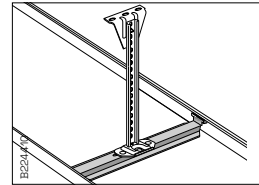

Support bracket W1960 mounted on Vertical piece 2 and Ceiling bracket 5. Screw set 22S must be used. For cable tray widths 500 och 600.

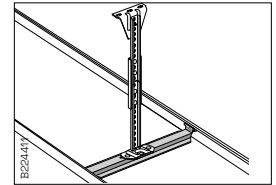

Support bracket W1960 can be mounted with Vertical piece 2, Pendant joint 2J, Pendant/ Fixing rail 24/34 and Ceiling bracket 5. Screw set 22S must be used. For cable tray widths 500 and 600.

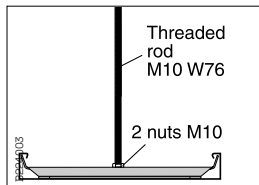

Alternatively, Tray W1/60 and W3/60, widths 500 and 600, can be installed with suitable Support bracket W1960, Threaded rod W76 M10 and 2 M10 nuts.

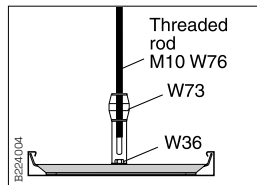

Alternatively, Tray W1/60 and W3/60, widths 500 and 600, can be installed with suitable Support bracket W1960, Threaded rod W76 M10 and Tube pendant attachment W73.

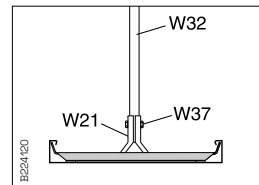

Alternatively, Tray W1/60 and W3/60, widths 500 and 600, can be installed with suitable Support bracket W1960, Pendant attachment W21 and Screw set W37.

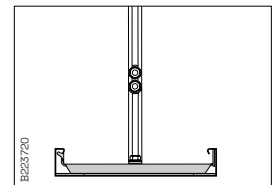

Tray W1/60 and W3/60 can be mounted on suitable Support bracket W1960 with 2 End brackets WN17 used as pendant. The end brackets are joined with 2 Screw sets 22S and can be adjusted in height. The pendant can be mounted in the support bracket with 1 Screw set W36.

Technical information

Use and installation

Internal cantilever arm W17

Internal cantilever arm to be used for invisible mounting inside cable tray W1/40 and W3/40.

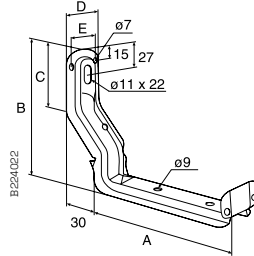
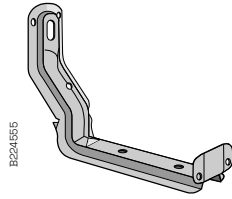

Type	A mm	B mm	C mm	D mm	E mm
W17/40-100	89	140	70	55	42
W17/40-200	189	140	70	55	42
W17/40-300	289	165	95	75	55
W17/40-400	389	165	95	75	55

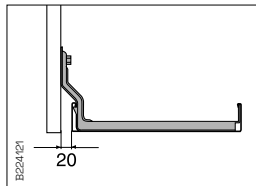

Internal cantilever arm W17/40 is mounted on Vertical piece 2F using a T-bolt.

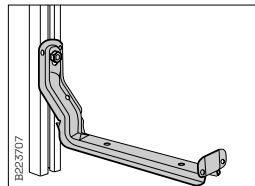

When mounting an Internal cantilever arm W17/40 on a porous wall or when surface pressure must be reduced use Mounting rail 40.

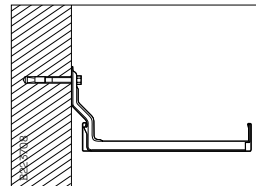

The Internal cantilever arm is mounted onto the wall with an Expansion bolt alt. a Concrete screw.

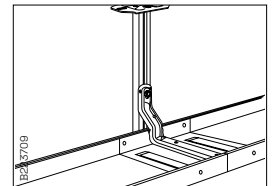

Internal cantilever arm W17/40 can be mounted right over support bracket/joint.

Loading table for Internal cantilever arm W17/40 on wall

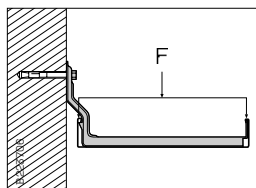

Mounted onto wall with Expansion bolt. Breaking load for cantilever arm mounted onto wall, see below.

Cantilever arm type	Max load F at 3° deflection of cantilever arm		Deflection in mm vid 3° deflection of cantilever arm mm	Breaking load	
	kN	kg		kN	kg
W17/40-100	1.0	100	5.2	3.0	300
W17/40-200	0.8	80	10.5	2.0	200
W17/40-300	1.1	110	15.7	3.0	300
W17/40-400	1.0	100	20.9	2.0	200

Technical information

Use and installation

Adjustable cantilever arm W1840

Adjustable cantilever arm to be used for invisible mounting inside cable trays W1/40 and W3/40. Adjustability 0-25 mm W1840-100 and 0-50 mm W1840-200 to 600.

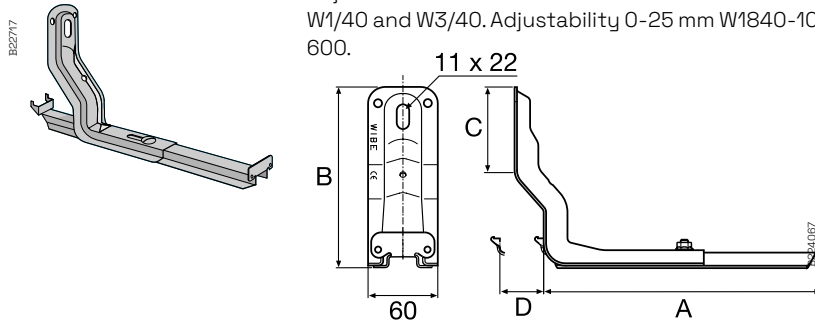

Type	A mm	B mm	C mm	D mm
W1840-100	88	160	70	0-25
W1840-200	188	160	70	0-50
W1840-300	289	185	95	0-50
W1840-400	389	185	95	0-50
W1840-500	489	185	95	0-50
W1840-600	589	185	95	0-50

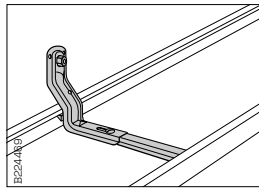

Mounting directly onto wall. At this type of installation the adjusting allowance of the tray is limited. Breaking load - see table above.

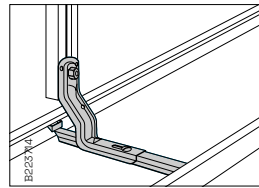

Mounting on Vertical piece 2F using T-bolt. The Cantilever arm W1840 can be adjusted to a max. of 50 mm.

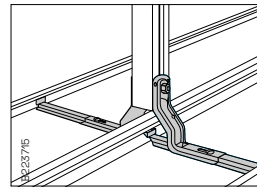

Mounting of two adjustable cantilever arms on the same Vertical piece 2F. (Tray widths more than 400 mm). Use Screw set 20S if the two trays have the same width. At different tray widths T-bolt 26U and Screw set W37 must be used.

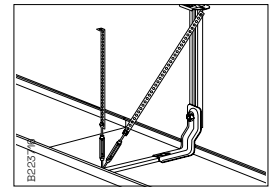

When mounting cable trays, widths 500-600 mm, it might be necessary with a reinforcement of the cantilever arm. Installation band and stretching screw can be used for mounting in ceiling or on a vertical piece.

Loading table for cantilever arm W1840 on wall

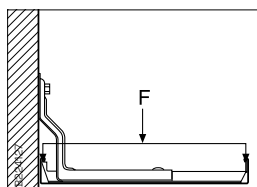

Mounted onto wall with Expansion bolt. Breaking load for cantilever arm mounted on wall.

type	Max load F at 3° deflection of cantilever arm		Deflection at 3° deflection of cantilever arm mm	Breaking load	
	kN	kg		kN	kg
W1840-100	1.0	100	5.2	3.0	300
W1840-200	0.8	80	10.5	2.0	200
W1840-300	1.1	110	15.7	3.0	300
W1840-400	1.0	100	20.9	2.0	200
W1840-500	0.65	65	26	1.3	130
W1840-600	0.5	50	31.5	1.0	100

Technical information

Use and installation

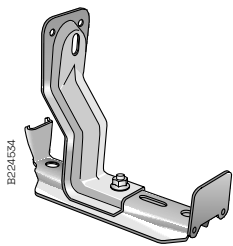

W1860 100-200

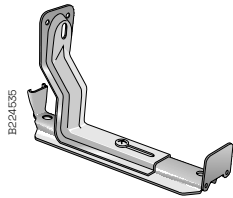

W1860 300-600

Adjustable cantilever arm W1860

Adjustable cantilever arm to be used for invisible mounting inside cable trays W1/60 and W3/60. Adjustability 0-25 mm W1860-100 and 0-50 mm W1860-200 to 60.

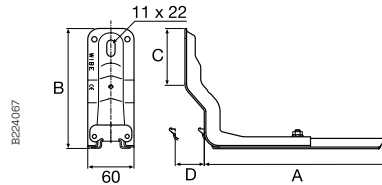

Type	A mm	B mm	C mm	D mm
W1860-100	89	160	70	0-25
W1860-200	189	160	70	0-50
W1860-300	289	185	95	0-50
W1860-400	389	185	95	0-50
W1860-500	489	185	95	0-50
W1860-600	589	185	95	0-50

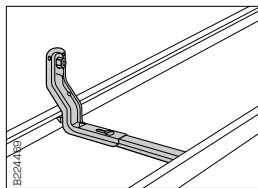

Mounting directly onto wall. At this type of installation the adjusting allowance of the tray is limited. Breaking load - see table below.

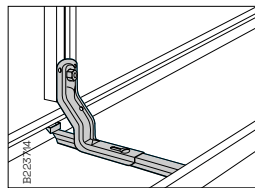

Mounting on Vertical piece 2F using T-bolt. The Cantilever arm W1860 can be adjusted to a max. of 50 mm.

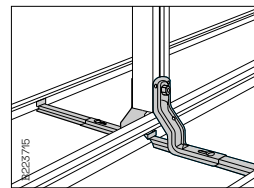

Mounting of two adjustable cantilever arms on the same Vertical piece 2F. (For trays wider than 400 mm). Use Screw set 20S if the two trays have the same width. At different tray widths T-bolt 26U and Screw set W37 must be used.

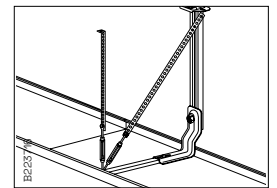

When mounting cable trays, widths 500-600 mm, it might be necessary with a reinforcement of the cantilever arm. Installation band and stretching screw can be used for mounting in ceiling or on a vertical piece.

Loading table for cantilever arm on wall

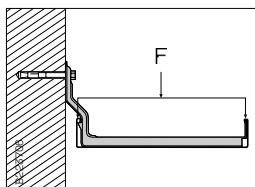

Mounted onto wall with Expansion bolt. Breaking load for cantilever arm mounted onto wall.

Cantilever arm type	Max load F at 3° deflection of cantilever arm		Deflection in mm at 3° deflection of cantilever arm	Breaking load	
	kN	kg		kN	kg
W1860-100	1.0	100	5.2	3.0	300
W1860-200	0.8	80	10.5	2.0	200
W1860-300	1.1	110	15.7	3.0	300
W1860-400	1.0	100	20.9	2.0	200
W1860-500	0.65	65	26.0	1.3	130
W1860-600	0.5	50	31.5	1.0	100

Technical information

Use and installation

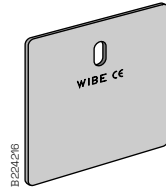

Back plate W30

Back plate to be used for wall installation of internal cantilever arms on porous walls, to reduce the surface pressure.

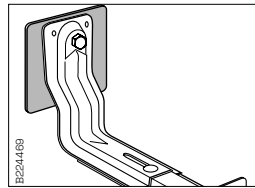
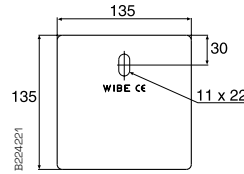

Mount Back plate W30 as shown in the illustration to reduce the surface stress on porous walls.

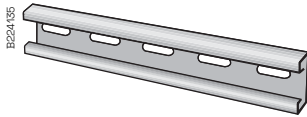

Mounting rail 40

Mounting rail to be used for wall installation of cantilever arms on porous walls to reduce the surface pressure or to enable height adjustment of cantilever arms.

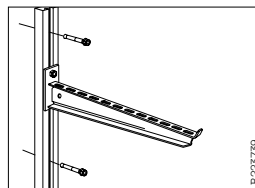
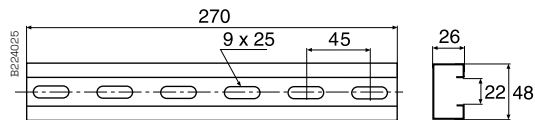

The mounting rail is installed between a cantilever arm and wall to reduce surface pressure on porous walls or to enable vertical adjustment of cantilever arms.

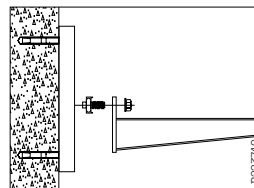

Cantilever arm 50 is installed using a T-bolt. The cantilever arm is vertically adjustable.

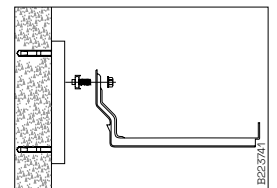

Internal cantilever arm W17 and Adjustable cantilever arm W1840 are mounted with T-bolt. The cantilever arm is vertically adjustable.

Technical information

Use and installation

Vertical piece 2Fi

Vertical piece to be used for lighter mountings with Cantilever arm 50i.

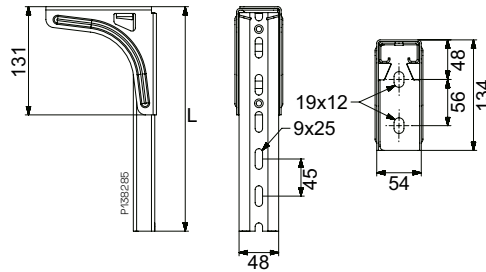
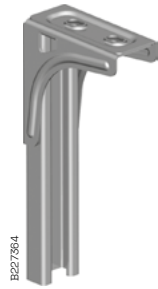

Type	L mm
Vertical piece 2Fi-300	272
Vertical piece 2Fi-500	497
Vertical piece 2Fi-750	722
Vertical piece 2Fi-1000	992

Loadings

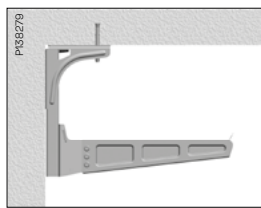

Vertical piece 2Fi can be mounted in ceiling close to wall.

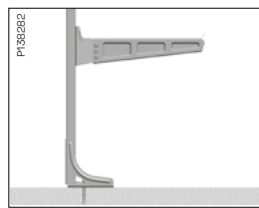

Vertical piece 2Fi is suitable for floor mounting.

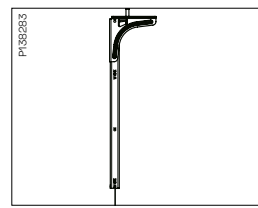

Vertical piece 2Fi mounted in the inner hole. Breaking load=500 kg (5 kN) at symmetrical loading.

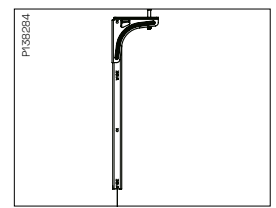

Vertical piece 2Fi mounted in the outer hole. Breaking load=100 kg (1 kN) at symmetrical loading.

Vertical piece 2F

Vertical piece to be used for installation of Internal cantilever arm W17/40, Adjustable cantilever arm W18/40 or Cantilever arm 50/50L. Can be joined to Pendant/fixing rail 24/48 with Pendant joint 2FJ.

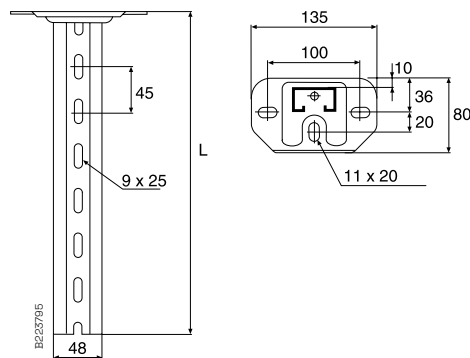
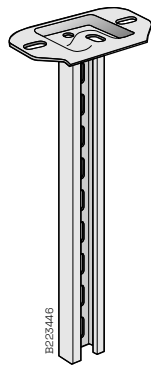

Type	L mm
Vertical piece 2F/280	280
Vertical piece 2F/370	370
Vertical piece 2F/505	505
Vertical piece 2F/640	640
Vertical piece 2F/730	730
Vertical piece 2F/865	865
Vertical piece 2F/1000	1000
Vertical piece 2F/1500	1495

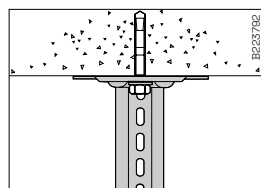

Mounted in ceiling with Expansion bolt alt. Concrete screw.

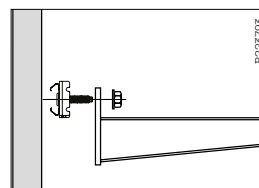

Cantilever arm 50 is mounted with a T-bolt 26U.

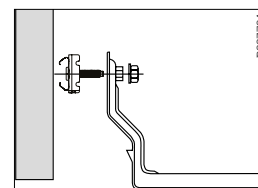

Internal cantilever arm W17/40 is mounted with a T-bolt 26U.

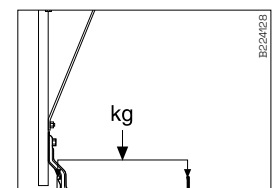

In order to reduce the deflection of Vertical piece 2F for heavy loads on Internal cantilever arm W17/40 and Adjustable cantilever arm W1840/W1860, Pendant bar 1 is installed.

Technical information

Use and installation

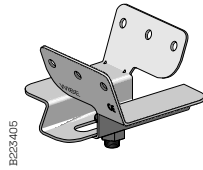

Ceiling bracket 5TPA

Ceiling bracket with telescopic function, to be used for mounting of various sizes of trapezoid plates. Including screw MVBF 8x16 and nut M6MF8. Breaking load: 150 kg without deformation.

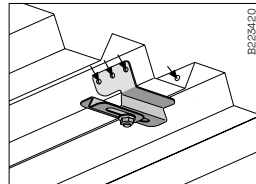
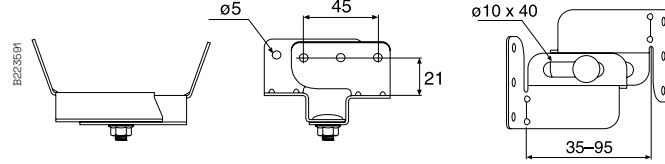

Ceiling bracket 5TPA can be mounted in trapezoid plate with blind rivets or suitable screws. The bracket is adjustable from 35 to 95 mm.

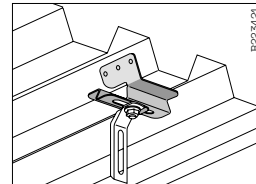

Pendant attachment W21 or Tube pendant attachment W73 (Wibe Cable Tray) can be mounted in Ceiling bracket 5TPA with the existing screw.

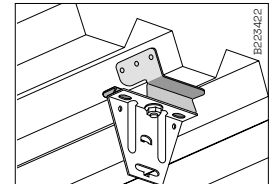

Ceiling bracket 5 or Ceiling attachment W31 can be mounted with the existing screw.

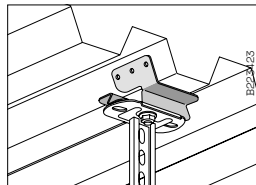

Vertical piece 2 or 2F can be mounted with the existing screw.

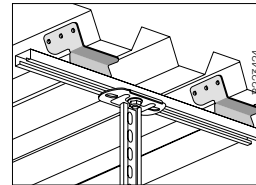

Install Mounting rail 40 between 2 Ceiling brackets 5TPA if the vertical piece must be adjusted sideways.

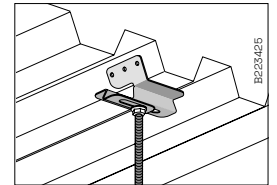

Pendant W76 M8 or M10 installed in Ceiling bracket 5TPA.

Breaking load

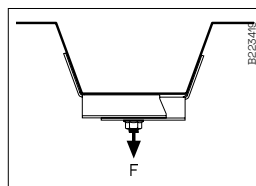

Ceiling bracket 5TPA can be loaded with $F=150$ kg without deformation. For loading figures for thin plate or fixing elements, follow suppliers recommendations.

Technical information

Use and installation

Ceiling attachment W31

Ceiling attachment to be used for installations with Pendant rail W32.

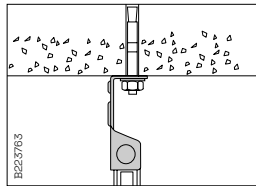
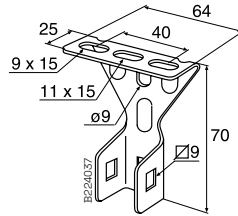
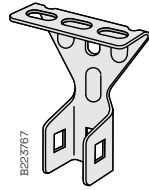

The Ceiling attachment W31 is mounted in concrete ceilings with one or two Expansion bolts. Pendant rail W32 is mounted with Screw set W37. Can be rotated 90°.

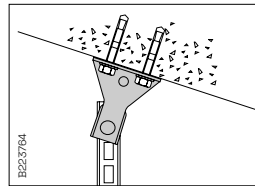

The Ceiling attachment W31 can be mounted directly in a slanted ceiling with Expansion bolts.

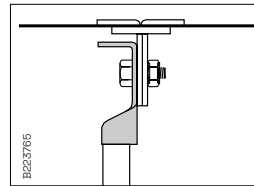

The Ceiling attachment W31 can be mounted directly in TP ceilings using an Ogebe fixing type E.

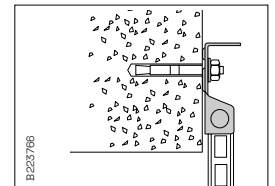

The Ceiling attachment W31 can be mounted onto a concrete beam with Expansion bolts.

Pendant rail W32

Pendant rail W32 can be installed in ceilings together with Ceiling attachment W31 or Ogebe fixing type E.

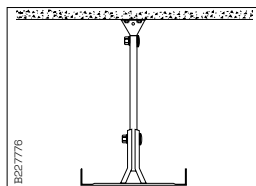
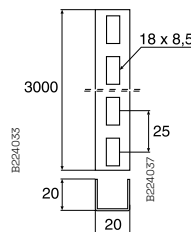
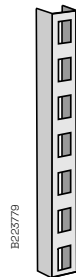

The Pendant rail W32 is cut to the required length and mounted in the ceiling with Ceiling attachment W31 and Pendant attachment W21 mounted onto Support bracket/joint W7.

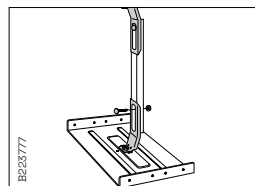

For lighter installations with small loads, one half of Pendant attachment W21 is mounted in Support bracket W7 with Screw set W36/ W36C. The second part is used as a ceiling bracket, Pendant rail W32 is mounted using Screw set W37.

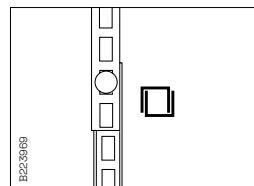

2 Pendant rails W32 can be joined by placing them over-lapping each other, see above. Use Screw set W37 for assembling.

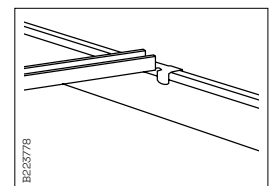

Using Locking clamp W77, the Pendant rail W32 can be mounted between two lighting trunkings or cable trays, either as a stabiliser or to form a simple duct.

Technical information

Use and installation

Pendant attachment W21

Pendant attachment to be used in combination with pendant rail W32, support bracket/joint W7, etc.

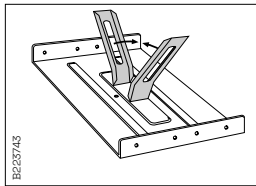
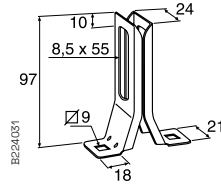
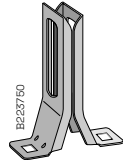

The Pendant attachment W21 is inserted into the slits in the Support bracket/joint W7 (100-400). Does not apply to W7-50,150,500 and 600.

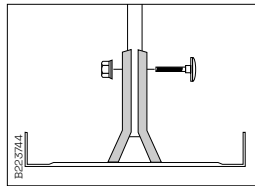

The required length of Pendant rail W32 is mounted in the Pendant attachment W21 with Screw set W37. Adjustable to ± 30 mm.

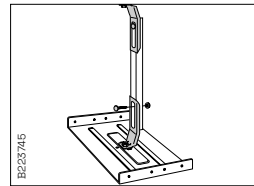

For lighter installations with small loads, only one half of the Pendant attachment W21 is mounted in Support bracket W7 with Screw set W36/W36C. The second part of the Pendant attachment W21 is used as a ceiling bracket. The Pendant rail W32 is mounted using Screw set W37.

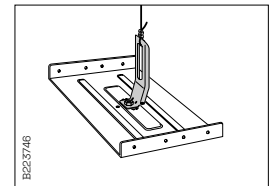

When mounting with wire, only one half of the Pendant attachment W21 is mounted in Support bracket/joint W7 using Screw set W36/W36C. The wire is mounted through the oval hole and locked with a wire lock.

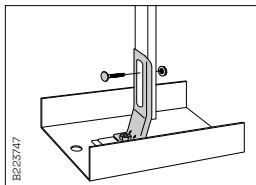

When mounting tray or Lighting trunking W70, one half of the Pendant attachment W21 is mounted directly in Support bracket/joint W7 with Screw set W36/W36C. The pendant rail is mounted with Screw set W37.

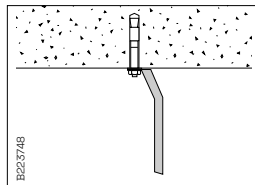

In concrete ceilings Pendant attachment W21 is mounted with Expansion bolt.

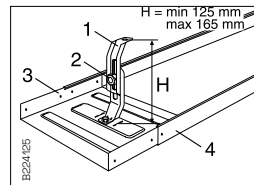

1. Pendant attachment W21
2. Screw set W36/W36C
3. Support bracket/joint W7
4. Cable tray/Lighting trunking

Ceiling installation with cable tray/lighting trunking

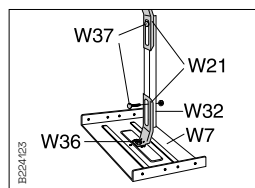
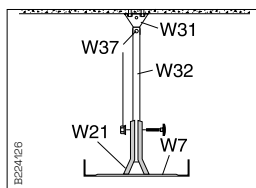

- W7 = Support bracket/joint
- W21 = Pendant attachment
- W31 = Ceiling attachment
- W32 = Pendant rail
- W36 = Screw set
- W37 = Screw set

Technical information

Use and installation

Pendant attachment W73

Tube pendant attachment to be used for mounting of threaded rod W76 M6, M8 or M10 in ceiling and cable tray. Provides a quick and screw-less height adjustment of the threaded rod.

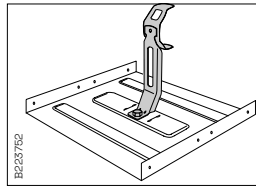
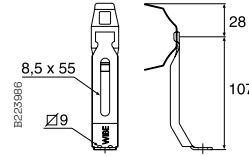

The Tube pendant attachment W73 is mounted in Support bracket/joint W7 with Screw set W36/W36C. Does not apply to W7-500 and 600.

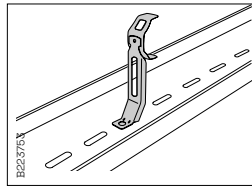

The Tube pendant attachment can be mounted directly in the lighting trunking using Screw set W36/W36C. Does not apply to Lighting trunking W70-40.

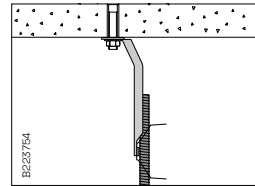

Threaded rod M6, M8 or M10 is easily mounted in the spring clasp without screws. Simple adjustment up to ±30 mm. Mounted in concrete ceilings with Expansion bolt.

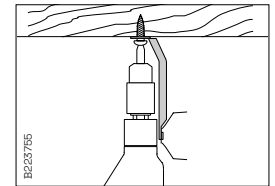

Mounted in wood with self-drilling screws.

Threaded rod B41 and W76 M6, M8, M10

Used for installation of cable trays and lighting trunkings.

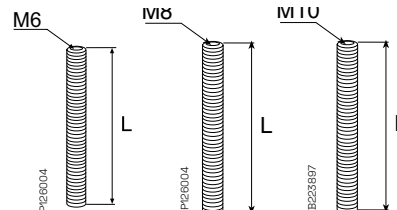

Type and Surface treatment	L= 1000mm	L= 2000mm	L= 3000mm
M6 EZ	W76	W76	W76
M8 EZ	W76	-	-
M10 EZ	-	W76	W76
M8 HDG	W76	W76	-
M8 AISI 316L	B41	B41	-
M10 AISI 316L	B41	B41	-

Technical information

Use and installation

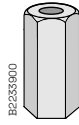

B2235900

Joint nut M6, M8, M10

Used for joining of Threaded rods.

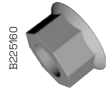

B22E60

Flange nut M6, M8, M10

Flange nut is mounted onto Threaded rods in order to lock support brackets and ceiling brackets.



B22E09

Thread lock M6, M8, M10

Used for joining of Threaded rod.

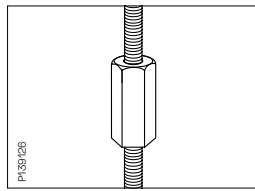

P13812B

Joint nut is used for joining of Threaded rods.

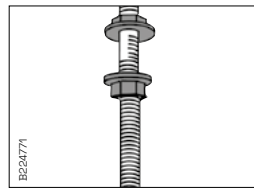

B22A771

Flange nuts are mounted onto the Threaded rod in order to lock support brackets and ceiling brackets.

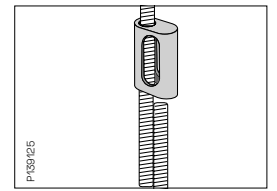

P138125

Thread lock is used for joining of Threaded rods. Max. permitted load=80kg

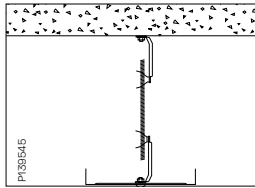

P138145

The Threaded rod is cut to required length and mounted with 2 Tube pendant attachments W73.

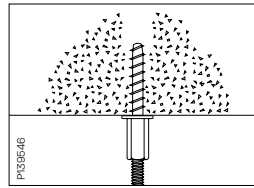

P138146

Installation of Threaded rod with Concrete screw MMS-I.

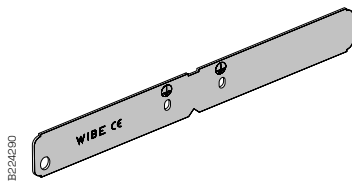

B224230

Side joint W49/40

Side joint to be used for straight joining of cable tray W1/40 and W3/40.

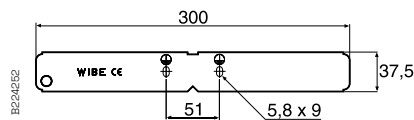

B224232

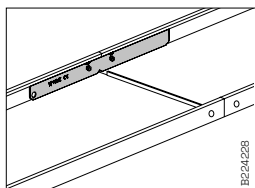

B224236

2 Side joints W49/40 are used for straight joining of Cable tray W1/40, W1/40 FS and W3/40. 4 Screw sets W38P are required (not included). For trays 300 mm and wider we recommend to use Support bracket/joint W7/40.

Technical information

Use and installation

BP224231

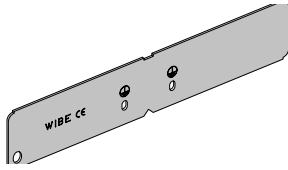

Side joint W49/60

Side joint to be used for straight joining of cable tray W1/60 and W3/60.

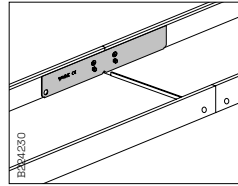
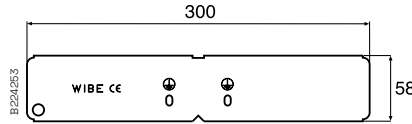

2 Side joints W49/60 are used for straight joining of Cable trays W1/60, W1/60 FS and W3/60. 4 Screw sets W38P are required (not included). For trays 300 mm and wider we recommend to use Support bracket/joint W7/60.

BP224540

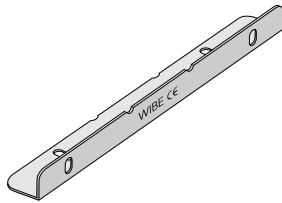

Joint W2

Side joint to be used for straight joining of installation tray W4.

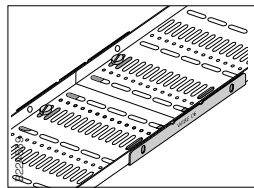
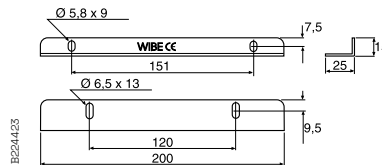

Used for joining Installation tray W4. To be mounted on the outside of the tray and attached in bottom with 2 Screw sets W34 (pre-galvanized, stainless steel and pre-galvanized powder coated trays). For hot dip galvanized and hot dip galvanized powder coated trays Screw set W38P must be used.

Technical information

Use and installation

T-joint W9/40

T-joint to be used to construct T-sections or X-sections. Also used for oblique branches. The ref. number includes two pieces of T-joints and Screw set W38P.

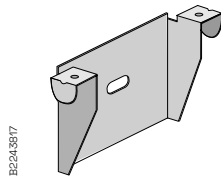

B22403617

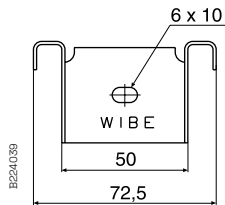

B224036

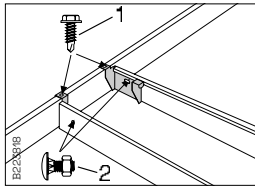

B2229819

Potential balancing

In order to fulfil the potential balancing according to SS-EN 61537 the T-joint must be secured with

- 1 Self-drilling screw RXB 4.2 x13
- 2 Screw set W38P, drilling is required.

Tightening torque 2 Nm.

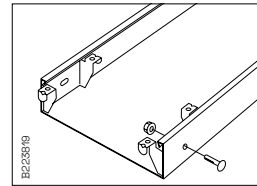

B2229819

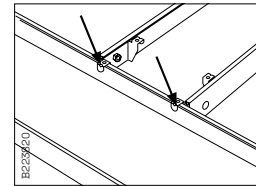

B2229819

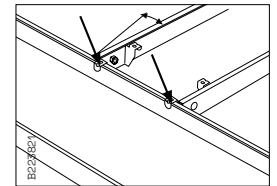

B2229819

Straight angling. If necessary, the lugs are locked to the edge of the tray using pliers. Can also be locked with blind rivets or selftapping screws.

Oblique angling. If necessary, the lugs are locked to the edge of the tray using pliers. Can also be locked with blind rivets or selftapping screws.

T-joint W9/60

T-joint to be used to construct T-sections or X-sections. Also used for oblique branches. The ref. number includes two pieces of T-joints and Screw set W38P.

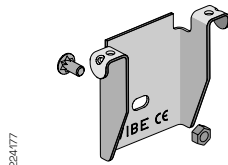

B224177

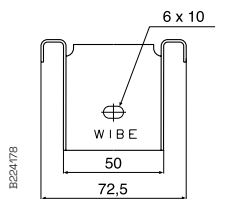

B224178

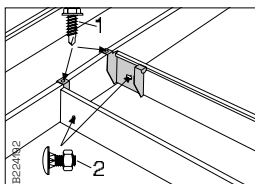

B224182

Potential balancing

In order to fulfil the potential balancing according to SS-EN 61537 the T-joint must be secured with

- 1 Self-drilling screw RXB 4.2 x13
- 2 Screw set W38P, drilling is required.

Tightening torque 2 Nm.

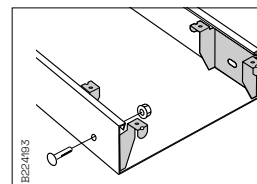

B224183

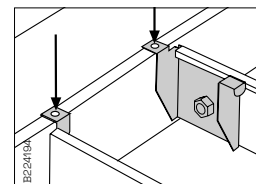

B224184

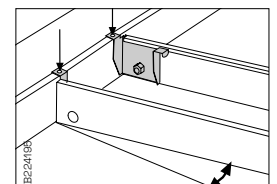

B224185

Straight branches. If necessary, the lugs are locked to the edge of the tray using pliers. Can also be locked with blind rivets or selftapping screws.

Oblique branches. If necessary, the lugs are locked to the edge of the tray using pliers. Can also be locked with blind rivets or selftapping screws.

Technical information

Use and installation

T-joint W29/40

T-joint to be used to construct T-junctions or X-junctions. Easy push-in assembly. Locks into the tray via locking flap. To be suspended over the lateral side of the tray and locked in a suitable way.

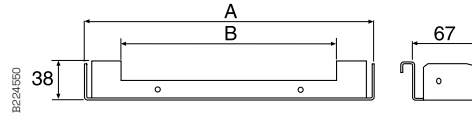
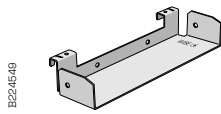

Type	A mm	B mm
T-joint W29/40-70	68	-
T-joint W29/40-100	98	-
T-joint W29/40-200	198	120
T-joint W29/40-300	301	220
T-joint W29/40-400	401	320
T-joint W29/40-500	501	420
T-joint W29/40-600	601	520

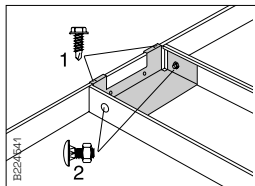

Potential balancing

In order to fulfil the potential balancing according to SS-EN 61537 the T-joint must be secured with

- 1 Self-drilling screw RXB 4 2 x 13
 - 2 Screw set W38P
- Tightening torque 2 Nm.

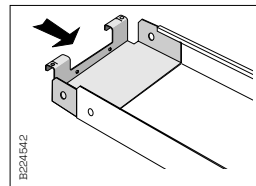

Simply installed with push-in mounting. Lock into tray with Screw set W38P.

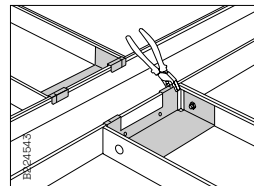

Used with T- and X-junction. Mounted directly onto tray edge. Can be attached to tray by pinching the lip at the top of the tray.

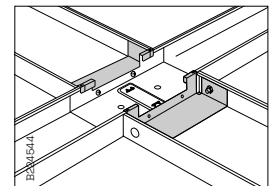

Used with open junction together with Joint W7/40 with opening and Tray W1/40 with opening. Attached with Screw set W38P.

Examples of suspensions with open junction where T-joint W29/40, Tray W1/40 with opening and Joint W7/40 with opening are included.

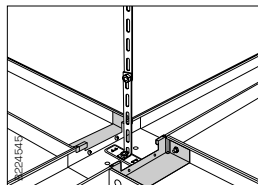

Suspension with Pendant strip W33.

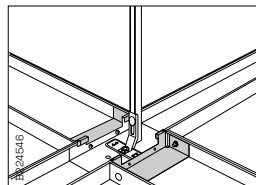

Suspension with Pendant rail W32 and half a Pendant attachment W21.

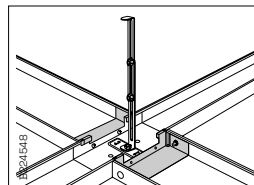

Suspension with End bracket WN17.

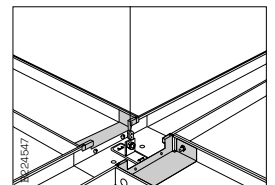

Suspension with wire and Ogebe fixing type E.

Technical information

Use and installation

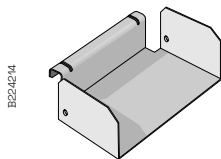

B224E14

T-joint W29/60

T-joint to be used to construct T-junctions or X-junctions. Easy push-in assembly. Locks into the tray via locking flap. To be suspended over the lateral side of the tray and locked in a suitable way.

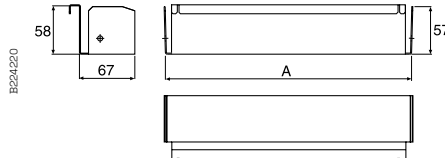

B224E20

Type	A mm
T-joint W29/60-70	68
T-joint W29/60-100	98
T-joint W29/60-200	198
T-joint W29/60-300	298
T-joint W29/60-400	398
T-joint W29/60-500	498
T-joint W29/60-600	598

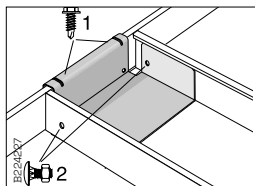

B224E17

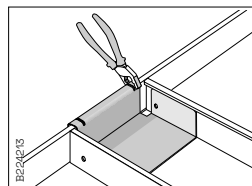

B224E13

Potential balancing

In order to fulfil the potential balancing according to SS-EN 61537 the T-joint must be secured with
 1 Self-drilling screw RXB 4.2 x 13
 2 Screw set W38P
 Tightening torque 2 Nm.

Used with T- and X-junction. Mounted directly onto tray edge. Can be attached to tray by pinching the lip at the top of the tray.

Technical information

Use and installation

Vertical riser W11/40, W11F/40

Vertical riser to be used as internal or external riser. Can be bent to the desired angle up to 90°. Push-in installation. The riser is delivered flat.

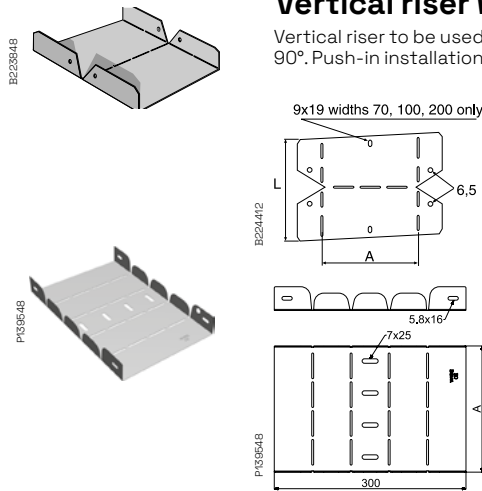

Type	A mm	L mm
Vertical riser W11/40-50	48	150
Vertical riser W11/40-70	68	150
Vertical riser W11/40-100	98	150
Vertical riser W11/40-150	148	150
Vertical riser W11/40-200	198	200
Vertical riser W11/40-300	298	200
Vertical riser W11/40-400	398	200
Vertical riser W11/40-500	498	200
Vertical riser W11/40-600	598	200
Vertical riser W11F/40-50	48	-
Vertical riser W11F/40-70	68	-
Vertical riser W11F/40-100	98	-
Vertical riser W11F/40-150	148	-
Vertical riser W11F/40-200	198	-
Vertical riser W11F/40-300	298	-
Vertical riser W11F/40-400	398	-
Vertical riser W11F/40-500	498	-
Vertical riser W11F/40-600	598	-

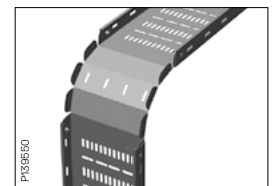
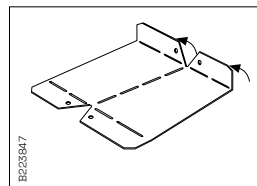
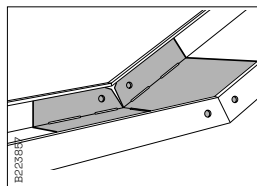
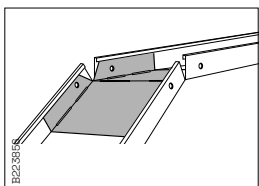

For upward or downward angling to a desired angle up to 90°. Should be locked with Screw set W38P or Locking plug W41.

Vertical riser W11/40 is delivered flat and must be bent by the installer on the job site.

Vertical riser W11F/40 is delivered flat, must be bent to the desired angle by the installer, used for vertical 90° angling. Screw set W38P is used for mounting.

Technical information

Use and installation

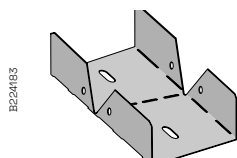

B224193

Vertical riser W11/60

Vertical riser to be used as internal or external riser. Can be bent to the desired angle up to 90°. Push-in installation. The riser is delivered flat.

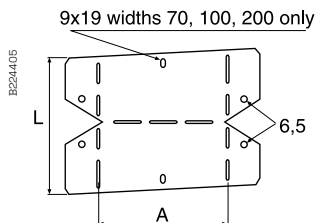

Type	A mm	L mm
Vertical riser W11/60-70	67	150
Vertical riser W11/60-100	97	150
Vertical riser W11/60-150	147	150
Vertical riser W11/60-200	197	200
Vertical riser W11/60-300	297	200
Vertical riser W11/60-400	397	200
Vertical riser W11/60-500	497	200
Vertical riser W11/60-600	597	200

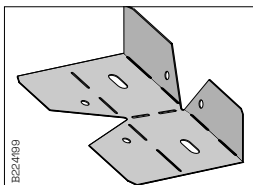

B224199

Vertical riser W11/60 is delivered flat and must be bent by the installer on the job site.

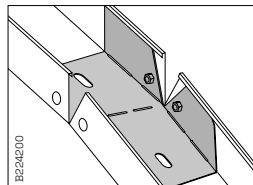

B224200

For upward or downward branching at a desired angle up to 90°. Push-in installation.

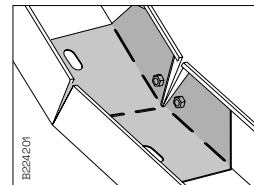

B224201

Should be attached with Screw set W38P or Locking plug W41.

Technical information

Use and installation

Vertical riser W4, interior

Vertical riser suitable for installation tray W4. To be used as internal or external riser. The riser is delivered flat and can be bent to the desired angle up to 90°.

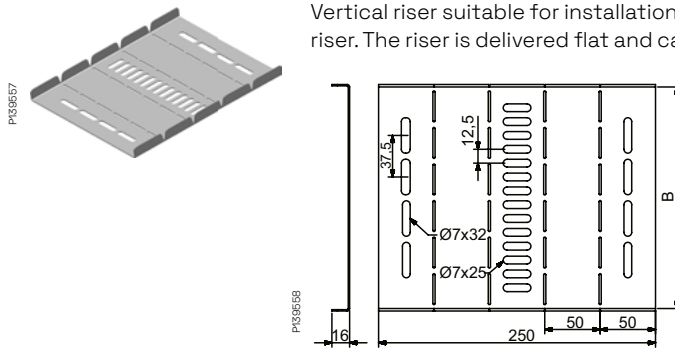

Type	B mm
Vertical riser W4-50	52
Vertical riser W4-75	77
Vertical riser W4-100	102
Vertical riser W4-150	152
Vertical riser W4-200	202
Vertical riser W4-250	252
Vertical riser W4-300	302
Vertical riser W4-400	402

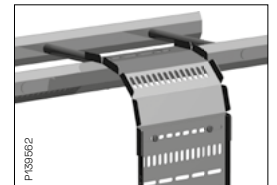
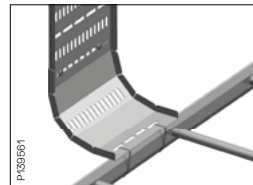
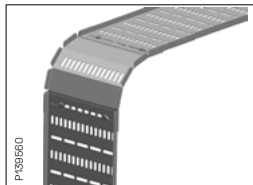
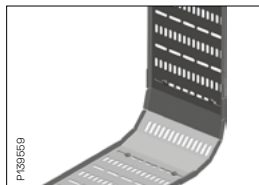

Vertical riser W4 is delivered flat, must be bent to the desired angle by the installer, used for vertical 90° angling. Mounted outside of trays W4. Attached in bottom with Screw set W34 (pre-galvanized, stainless steel and pre-galvanized powder coated trays). For hot dip galvanized trays Screw set W38P must be used.

When used for vertical 90° angling from cable ladder the vertical riser is attached to the cable ladder with strips.

Technical information

Use and installation

Adjustable bend W10S/40

Adjustable bend to be used for horizontal angling from 105° to 165° in steps of 7.5°. Push-in installation.

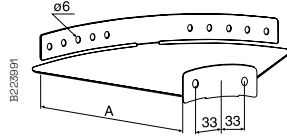
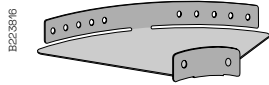

Type	A mm
Adjustable bend W10/40-50	47
Adjustable bend W10/40-70	67
Adjustable bend W10/40-100	97
Adjustable bend W10/40-150	147
Adjustable bend W10/40-200	197
Adjustable bend W10/40-300	297
Adjustable bend W10/40-400	397
Adjustable bend W10/40-500	497
Adjustable bend W10/40-600	597

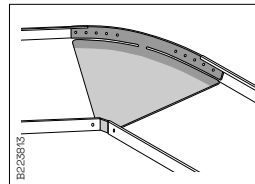

Push-in installation. Turn up inner and outer sides and mount the Adjustable bend W10/40 inside the tray.

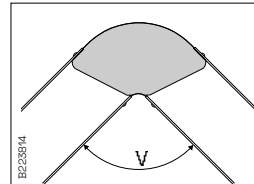

Adjustable bend W10/40 permits desired horizontal angling between 105° and 165° in stages of 7.5°.

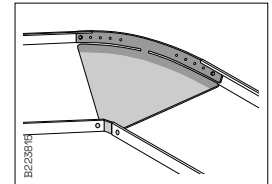

If necessary, Adjustable bend W10/40 may be locked using Screw set W38P or Locking plug W41.

Adjustable bend W10S/60

Adjustable bend to be used for horizontal angling from 105° to 165° in steps of 7.5°. Push-in installation.

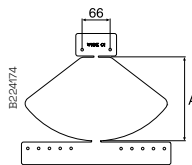
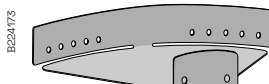

Type	A mm
Adjustable bend W10/60-70	67
Adjustable bend W10/60-100	97
Adjustable bend W10/60-150	147
Adjustable bend W10/60-200	197
Adjustable bend W10/60-300	297
Adjustable bend W10/60-400	397
Adjustable bend W10/60-500	497
Adjustable bend W10/60-600	597

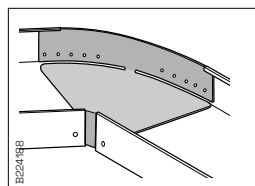

Push-in installation. Turn up inner and outer sides and mount the Adjustable bend W10/60 inside the tray.

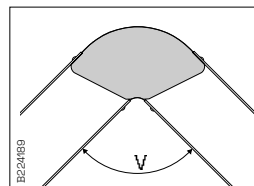

Adjustable bend W10/60 permits desired horizontal angling between 105° and 165° in stages of 7.5°.

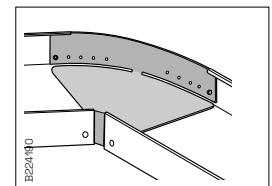

If necessary, Adjustable bend W10/60 may be locked using Screw set W38P or Locking plug W41.

Technical information

Use and installation

E223812

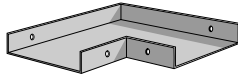

90° bend W10/40

Horizontal 90° bend to be used for cable trays W1/40 and W3/40. Push-in assembly.

E223973

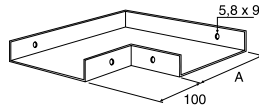

Type	A mm
90° bend W10/40-70	67
90° bend W10/40-100	97
90° bend W10/40-200	197
90° bend W10/40-300	297
90° bend W10/40-400	397
90° bend W10/40-500	497
90° bend W10/40-600	597

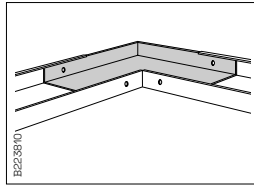

Used for 90° horizontal angling. Suspension components should be mounted in or in connection with the junction. Push-in installation.

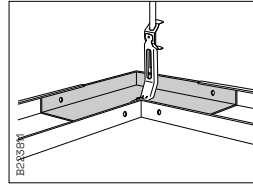

If necessary, the 90° bend W10/40 can be locked using Screw set W38P or Locking plug W41. Can be provided with holes in bottom for suspension in Pendant attachment W21 alternatively W73. Valid for max. width 200 mm.

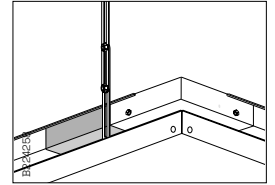

Support bracket/joint W7/40, with a suitable pendant, is used to achieve an invisible suspension, here with End bracket WN17 mounted as vertical piece.

Technical information

Use and installation

90° bend W10/60

Horizontal 90° bend to be used for cable trays W1/60 and W3/60. Push-in assembly.

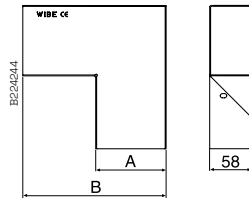
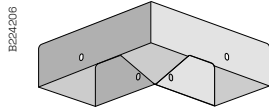

Type	A mm	B mm
90° bend W10/60-70	67	167
90° bend W10/60-100	97	197
90° bend W10/60-150	147	247
90° bend W10/60-200	197	297
90° bend W10/60-300	297	397
90° bend W10/60-400	397	497
90° bend W10/60-500	497	597
90° bend W10/60-600	597	697
90° bend W10/60-500 FS	497	597
90° bend W10/60-600 FS	597	697

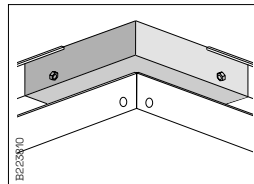

Used for 90° horizontal angling. Suspension components should be mounted in or in connection with the bend. Push-in installation.

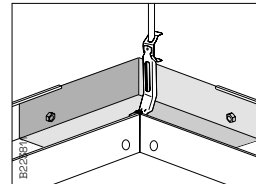

If necessary, the 90° bend W10/60 can be locked using Screw set W38P or Locking plug W41. Can be provided with holes in bottom for suspension in Pendant attachment W21 alternatively Tube pendant attachment W73. Valid for max. width 200 mm.

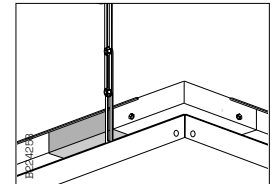

Support bracket/joint W7/60, with a suitable pendant, is used to achieve an invisible suspension, here with End bracket WN17 mounted as vertical piece.

Technical information

Use and installation

90° bend W10F/40

Horizontal 90° bend to be used for cable trays W3/40. Push-in assembly.

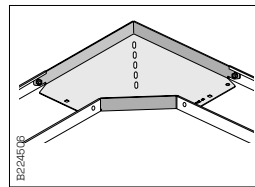
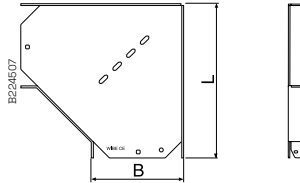
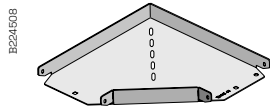

Used for 90° horizontal angling. Suspension components should be mounted in or in connection with the junction. Push-in installation.

Type	B mm	L m
90° bend W10F/40-50	47	119
90° bend W10F/40-70	67	153
90° bend W10F/40-100	97	204
90° bend W10F/40-150	147	290
90° bend W10F/40-200	197	375
90° bend W10F/40-300	297	480
90° bend W10F/40-400	397	580
90° bend W10F/40-500	497	714
90° bend W10F/40-600	597	814

90° bend W4

90° bend to be used for cable tray W4. To be mounted on the outside of the tray and attached in the bottom segment with screw set W34.

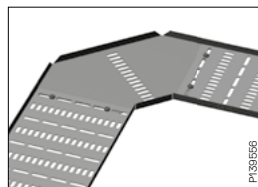
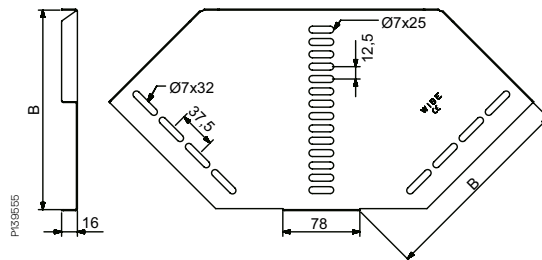
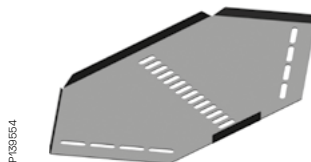

Used for horizontal 90° angling. Mounted outside of W4 trays. Attached in bottom with Screw set W34 (pre-galvanized, stainless steel and pre-galvanized powder coated trays). For hot dip galvanized trays Screw set W38P must be used.

Type	B mm
90° bend W4-50	52
90° bend W4-75	77
90° bend W4-100	102
90° bend W4-150	152
90° bend W4-200	202
90° bend W4-250	252
90° bend W4-300	302
90° bend W4-400	402

Technical information

Use and installation

B223853

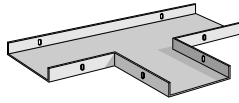

T-junction W12/40

T-junction to be used for 90° horizontal junction of cable trays W1/40 and W3/40. Push-in assembly.

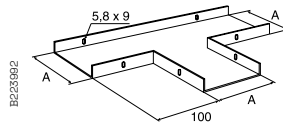

Type	A mm
T-junction W12/40-50	46
T-junction W12/40-70	67
T-junction W12/40-100	97
T-junction W12/40-200	197
T-junction W12/40-300	297
T-junction W12/40-400	397
T-junction W12/40-500	497
T-junction W12/40-600	597

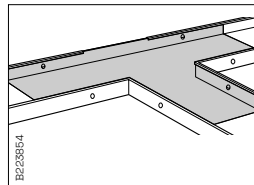

Used for horizontal 90° junction. Suspension components should be mounted in or in connection with the junction. Push-in installation.

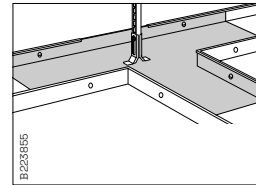

If necessary, the T-junction W12/40 can be locked using Screw set W38P or Locking plug W41. Can be provided with holes in bottom for suspension in Pendant attachment W21 or Tube pendant attachment W73. Valid for max. width 200 mm.

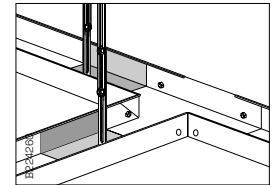

Support bracket/joint W7/40, with a suitable pendant, is used to achieve an invisible suspension, here with End bracket WN17 mounted as vertical piece.

Technical information

Use and installation

T-junction W12/60

T-junction to be used for 90° horizontal junction of cable trays W1/60 and W3/60. Push-in assembly.

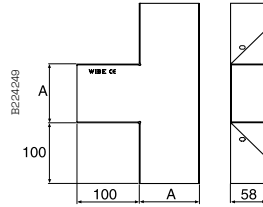
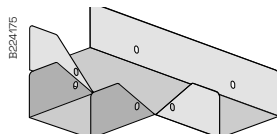

Type	A mm
T-junction W12/60-70	67
T-junction W12/60-100	97
T-junction W12/60-150	147
T-junction W12/60-200	197
T-junction W12/60-300	297
T-junction W12/60-400	397
T-junction W12/60-500	497
T-junction W12/60-600	597
T-junction W12/60-500 FS	497
T-junction W12/60-600 FS	597

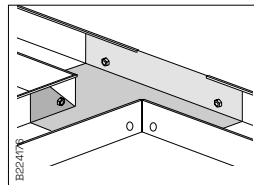

Used for 90° horizontal junction. Suspension components should be mounted in or in connection with the junction. Push-in installation.

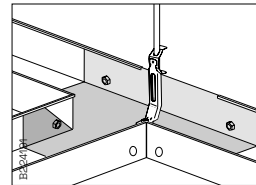

If necessary, the junction can be locked using Screw set W38P or Locking plug W41. Can be provided with holes in bottom for suspension in Pendant attachment W21 alternatively Tube pendant attachment W73. Valid for max. width 200 mm.

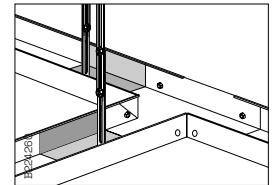

Support bracket/joint W7/60, with a suitable pendant, is used to achieve an invisible suspension, here with End bracket WN17 mounted as vertical piece.

Technical information

Use and installation

T-junction W12F/40

T-junction to be used for 90° horizontal junction of cable trays W3/40. Push-in assembly.

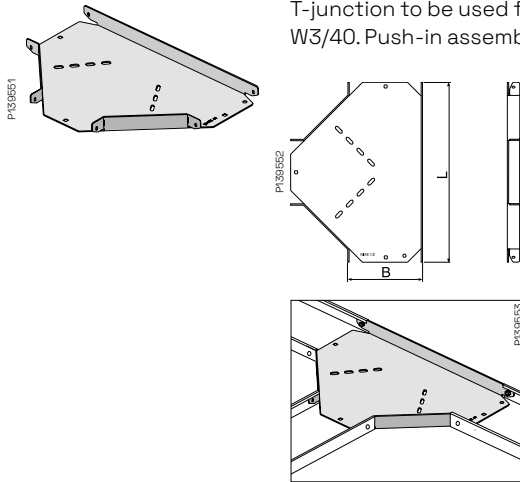

Type	B mm	L m
T-junction W12F/40-50	47	171
T-junction W12F/40-70	67	219
T-junction W12F/40-100	97	312
T-junction W12F/40-150	147	432
T-junction W12F/40-200	197	553
T-junction W12F/40-300	297	662
T-junction W12F/40-400	397	762
T-junction W12F/40-500	497	932
T-junction W12F/40-600	597	1032

Used for horizontal 90° junction. Suspension components should be mounted in or in connection with the junction. Push-in installation.

X-junction W13/40

X-junction to be used for 90° horizontal junction of cable trays W1/40 and W3/40. Push-in assembly.

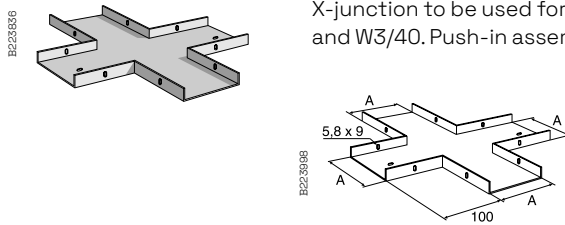

Type	A mm
X-junction W13/40-50	46
X-junction W13/40-70	67
X-junction W13/40-100	97
X-junction W13/40-200	197
X-junction W13/40-300	297
X-junction W13/40-400	397
X-junction W13/40-500	497
X-junction W13/40-600	597

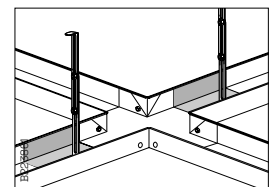
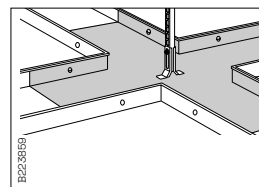
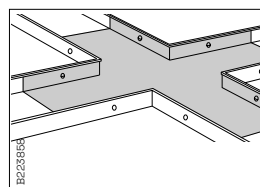

Used for horizontal 90° junction of four trays with the same width. Suspension components should be mounted in or in connection with the junction. Push-in installation.

If necessary, the X-junction W13/40 can be locked using Screw set W38P or Locking plug W41. Can be provided with holes in bottom for suspension in Pendant attachment W21 or Tube pendant attachment W73. Valid for max. width 200 mm.

Support bracket/joint W7/40, with a suitable pendant, is used to achieve an invisible suspension, here with End bracket WN17 mounted as vertical piece.

Technical information

Use and installation

X-junction W13/60

X-junction to be used for 90° horizontal junction of cable trays W1/60 and W3/60. Push-in assembly.

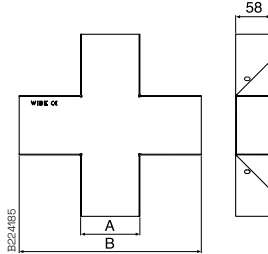
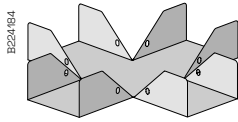

Type	A mm	B mm
X-junction W13/60-70	67	268
X-junction W13/60-100	97	298
X-junction W13/60-150	147	348
X-junction W13/60-200	197	398
X-junction W13/60-300	297	498
X-junction W13/60-400	397	598
X-junction W13/60-500	497	698
X-junction W13/60-600	597	798
X-junction W13/60-500 FS	497	698
X-junction W13/60-600 FS	597	798

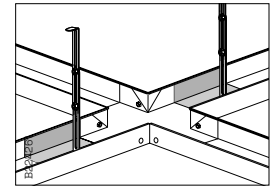
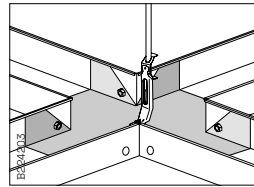
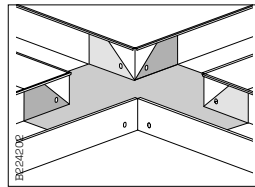

Used for 90° horizontal junction of four trays with the same width. Suspension components should be mounted in or in connection with the junction. Push-in installation.

If necessary, the junction can be locked using Screw set W38P or Locking plug W41. Can be provided with holes in bottom for suspension in Pendant attachment W21 alternatively Tube pendant attachment W73. Valid for max. width 200 mm.

Support bracket/joint W7/60, with a suitable pendant, is used to achieve an invisible suspension, here with End bracket WN17 mounted as vertical piece.

X-junction W13F/40

X-junction to be used for 90° horizontal junction of cable trays W3/40. Push-in assembly.

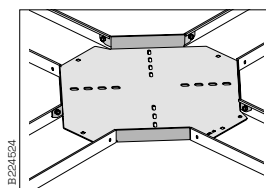
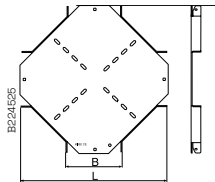
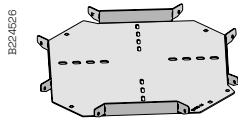

Type	B mm	L m
X-junction W13F/40-50	47	148
X-junction W13F/40-70	67	217
X-junction W13F/40-100	97	313
X-junction W13F/40-150	147	434
X-junction W13F/40-200	197	555
X-junction W13F/40-300	297	662
X-junction W13F/40-400	397	762
X-junction W13F/40-500	497	932
X-junction W13F/40-600	597	1032

Used for horizontal 90° junction of four trays with the same width. Suspension components should be mounted in or in connection with the junction. Push-in installation.

Technical information

Use and installation

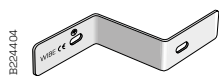

Reducer W28/40

Reducer for 40 mm high cable trays W1 and W3. To be used together with side joint W49 in side transitions. In centered transitions only two reducers W28 are necessary.

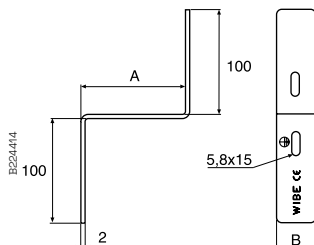

Type	A mm	B mm
Reducer W28/40-50	50	37.5
Reducer W28/40-100,	100	37.5
Reducer W28/40-150	150	37.5
Reducer W28/40-200	200	37.5
Reducer W28/40-250	250	37.5
Reducer W28/40-300	300	37.5
Reducer W28/40-350	350	37.5
Reducer W28/40-400	400	37.5
Reducer W28/40-450	450	37.5
Reducer W28/40-500	500	37.5

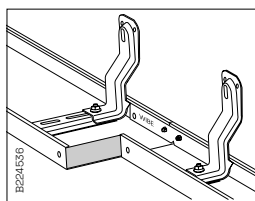

Used together with 1 Side joint W49/40 at one-side transition joining of Cable tray W1/40 and W3/40, to be mounted with 2 Screw sets W38P. Always use support close to the reducer.

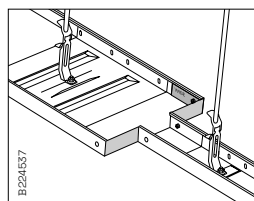

2 Reducers W28/40 are used at centered transition joining, to be mounted with Screw set W38P. Always use support close to the reducer.

Technical information

Use and installation

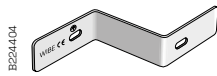

Reducer W28/60

Reducer for 60 mm high cable trays W1 and W3. To be used together with side joint W49 in side transitions. In centered transitions only two reducers W28 are necessary.

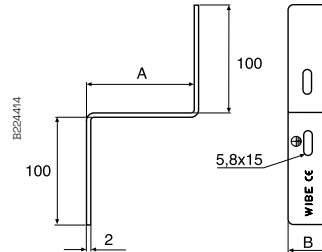

Type	A mm	B mm
Reducer W28/60-50	50	57.5
Reducer W28/60-100	100	57.5
Reducer W28/60-150	150	57.5
Reducer W28/60-200	200	57.5
Reducer W28/60-250	250	57.5
Reducer W28/60-300	300	57.5
Reducer W28/60-350	350	57.5
Reducer W28/60-400	400	57.5
Reducer W28/60-450	450	57.5
Reducer W28/60-500	500	57.5

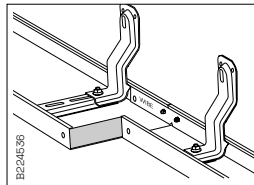

Used together with 1 Side joint W49/60 at one-side transition joining of Cable trays W1/60 and W3/60, to be mounted with 2 Screw sets W38P. Always use support close to the reducer.

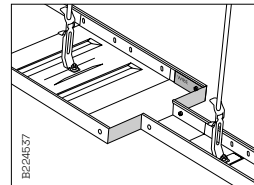

2 Reducers W28/60 are used at centered transition joining, to be mounted with Screw set W38P. Always use support close to the reducer.

Technical information

Use and installation

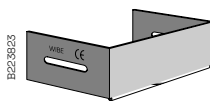

End cover W45/40

End cover to be mounted at the ends of cable trays W1/40 and W3/40 and of lighting trunkings W70. Provided with oval holes 6x55 mm on the sides. Push-in assembly.

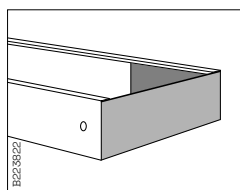
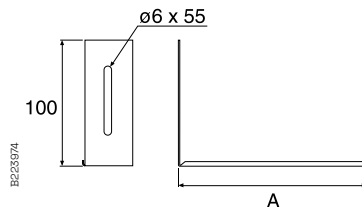

Mounted as end in trays and lighting trunkings. Locked with Locking plug W41 or Screw set W38P.

Type	A mm
End cover W45/40-70	68
End cover W45/40-100	98
End cover W45/40-150	148
End cover W45/40-200	198
End cover W45/40-300	298
End cover W45/40-400	398
End cover W45/40-500	498
End cover W45/40-600	598

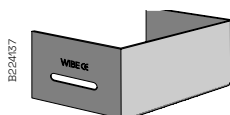

End cover W45/60

End cover to be mounted at the ends of cable trays W1/60 and W3/60. Provided with oval holes 6x55 mm on the sides. Push-in assembly.

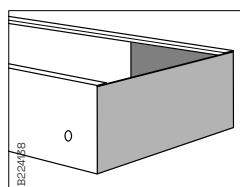
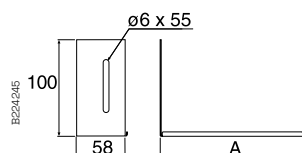

Mounted as end cover in cable trays. Locked with Screw set W38P or Locking plug W41.

Type	A mm
End cover W45/60-70	68
End cover W45/60-100	98
End cover W45/60-200	198
End cover W45/60-300	298
End cover W45/60-400	398
End cover W45/60-500	498
End cover W45/60-600	598

Technical information

Use and installation

Junction box plate W24/40

Junction box plate, with or without perforated hole pattern. To be used for the installation of junction boxes, light fittings, etc., in cable trays W1/40 and W3/40 and in lighting trunking W70.

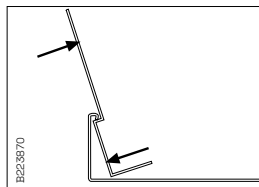
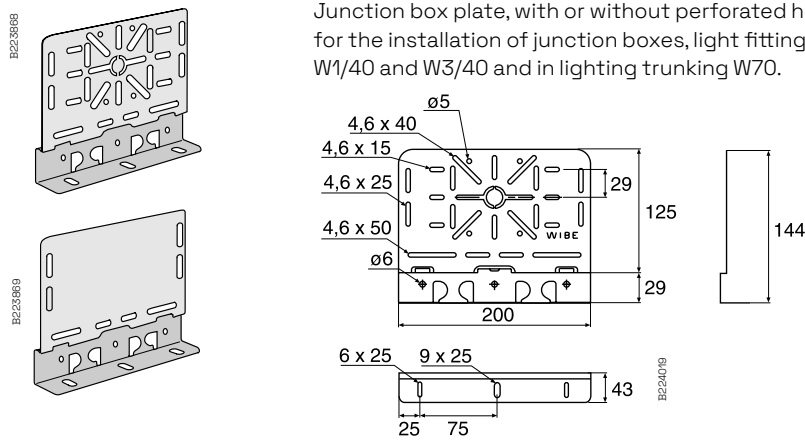

The Junction box plate W24/40 is mounted between the bottom of the trunking or tray and its folded seam.

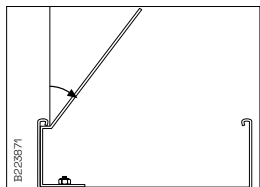

If necessary, the Junction box plate W24/40 can be screwed tight directly in Tray W3/40 with Screw set W38P. If one requires a hidden socket box, the junction box should be folded inwards.

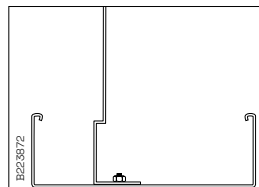

Can be mounted in the middle of Lighting trunking W70-100 and W70-200 with Screw set W36 or Tray W3/40 with Screw set W38P.

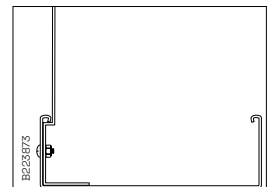

To firmly attach Junction box plate W24/40 in Tray W1/40 or W3/40, use blind rivets, selftapping screws or Screw set W38P.

Junction box plate W24/60

Junction box plate, with perforated hole pattern. To be used for the installation of junction boxes, light fittings, etc., in cable trays W1/60 and W3/60.

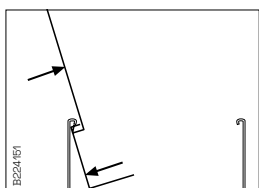
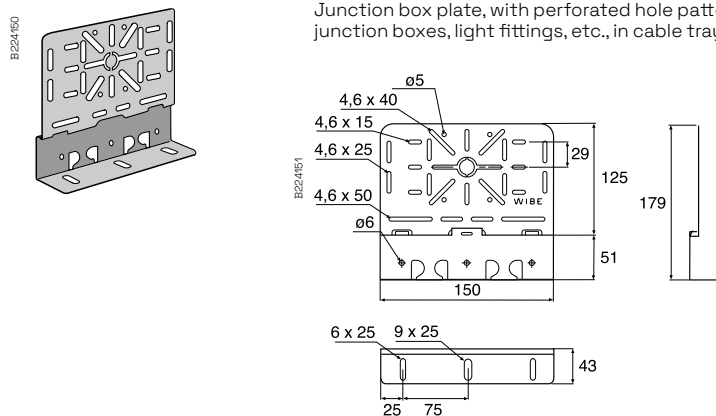

The Junction box plate W24/60 is mounted between the bottom of the tray and its folded seam.

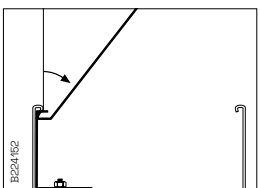

If necessary, the Junction box plate W24/60 can be tightened directly in Tray W3/60 with Screw set W38P. If one requires a hidden socket box, the junction box should be folded inwards.

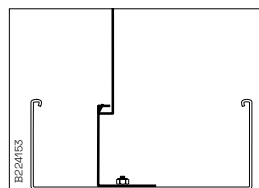

Can be mounted in the middle of Tray W3/60 with Screw set W38P.

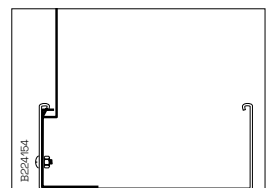

To firmly attach Junction box plate W24/60 in Tray W1/60 or W3/60, use blind rivets, selftapping screws or Screw set W38P.

Technical information

Use and installation

Luminaire bracket W25/40

Luminaire bracket to be used for assembly of light fixtures under Cable trays W1/40 and W3/40 or Lighting trunking W70.

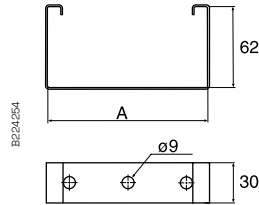
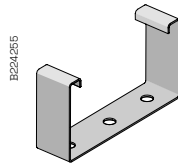

Type	A mm
Luminaire bracket W25/40-70	72
Luminaire bracket W25/40-100	101
Luminaire bracket W25/40-200	201
Luminaire bracket W25/40-300	301
Luminaire bracket W25/40-400	401
Luminaire bracket W25/40-500	501
Luminaire bracket W25/40-600	601

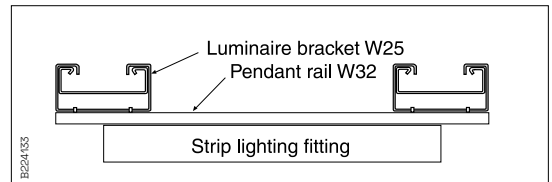
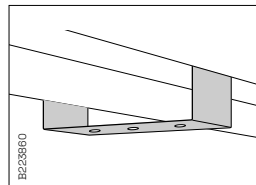

Used for installation of light fittings under tray or trunking. Can easily be moved along the tray or trunking.

For mounting of light fittings between and under two trays or lighting trunking. The light fitting is easily moved along the tray or lighting trunking.

Luminaire bracket W25/60

Luminaire bracket to be used for assembly of light fixtures under Cable trays W1/60 and W3/60.

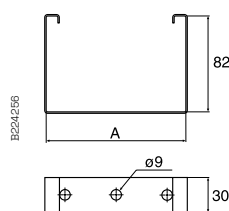
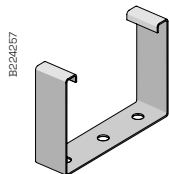

Type	A mm
Luminaire bracket W25/60-70	72
Luminaire bracket W25/60-100	101
Luminaire bracket W25/60-200	201
Luminaire bracket W25/60-300	301
Luminaire bracket W25/60-400	401
Luminaire bracket W25/60-500	501
Luminaire bracket W25/60-600	601

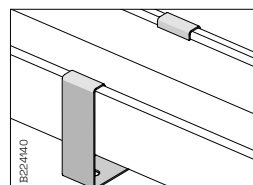
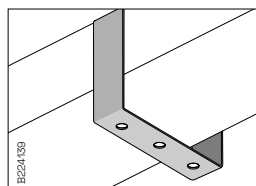

The luminaire bracket can easily be moved along the tray.

For mounting of lighting fittings under Cable tray W1/60 and W3/60.

Technical information

Use and installation

Fixings - Ogebe

The Ogebe fixing is a patented fixing intended for use when mounting plating with a thickness of 0.7-0.9 mm and 13 mm gypsum board. Pendants, cantilevers and holed strips can be mounted with these fittings.

Technical data

Material	Cold-rolled sheet steel SS 1142-32	Nut	Locking Nut M8, SMS 2165 FZB
Material treatment	Case-hardened	Bolt	M8 x 16 mm FZB
Surface treatment	Electro-galvanized	Washer	SRB 13.5 x 26 x 2 mm FZB
Maximum load	See load tables		

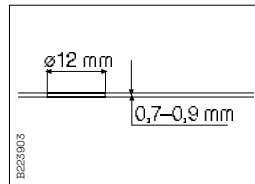

Drill a 12 mm dia. hole. A 10 mm drill can be used if one increases the hole dia. by slanting the electric drill.

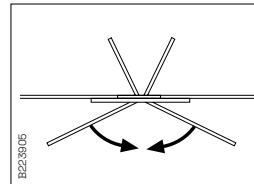

Place the accompanying washer over the thin legs. Insert the legs through the drilled hole and fold the broader legs towards each other. If sealing is required, a standard sealing mass from building retailers can be used.

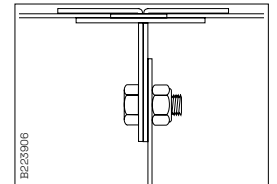

Mount the pendant, bracket or holed strip with the enclosed bolts and nuts. (The nut should always be a locking nut).

Breaking load

The load applied at an equi-distance between 2 beams 600 mm apart. The values are taken from Swedish National Testing Institute Report 8410.0032 1984-09-28.

Type of fixing	Sheeting 0.7 mm			Sheeting 0.9 mm			Gypsum 13 mm		
	F1	F2	F3	F1	F2	F3	F1	F2	F3
E	1,01 kN 101 kg	2,14 kN 214 kg	1,85 kN 185 kg	1,77 kN 177 kg	2,43 kN 243 kg	2,05 kN 205 kg			

Fixing type E

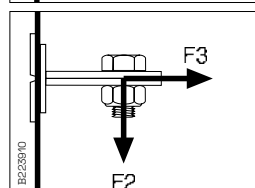
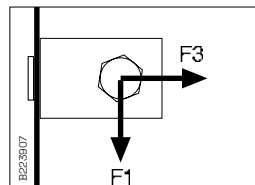

Technical information

Use and installation

Ogebe fixing type E

Ogebe fixing type E to be used for mounting in 0.7-0.9 mm sheeting or board material. Examples are hole straps, pendants, ducts, trays and piping.

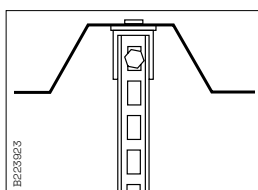
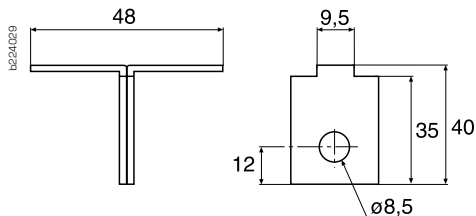
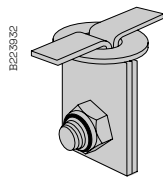

Mounting of Pendant rail W32.

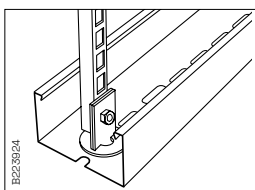

Mounting of Pendant rail W32 with Ogebe fixing type E direct in lighting trunking.

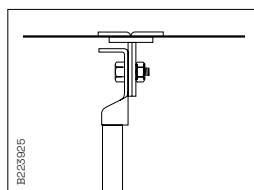

Mounting of Ceiling attachment W31 on Ogebe fixing type E

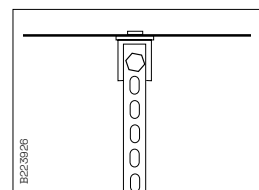

Mounting of hole strap.

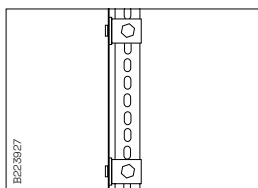

Stand installation on wall.

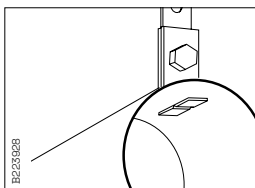

Suspension of duct or pipe.

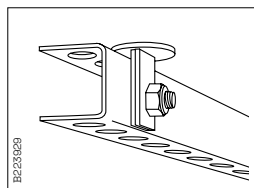

Mounting of holed beam.

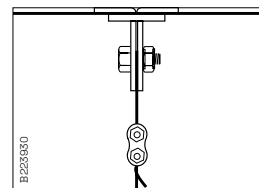

A wire can be mounted directly in the Ogebe fixing type E.

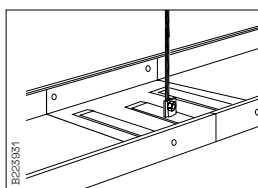

The Ogebe fixing type E can be mounted direct into Support bracket/joint W7.

Technical information

Use and installation



Cantilever arm 50i

Cantilever arm to be used for lighter mountings on walls, vertical pieces or pendant/fixing rails.

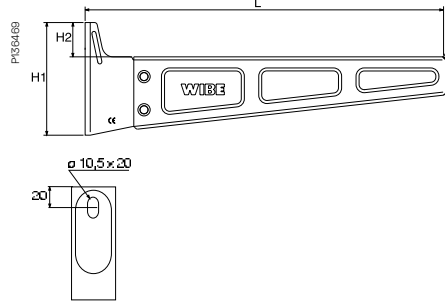

Cantilever arm type	Size		
	L mm	H1 mm	H2 mm
50i-100	150	80	32
50i-200	250	85	28.5
50i-300	350	110	33.5
50i-400	450	115	31.0
50i-500	550	150	31
50i-600	650	150	31

Widths = 100

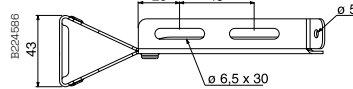

Widths = 200

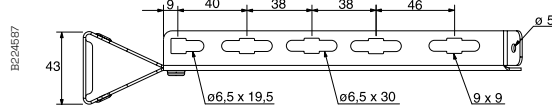

Widths = 300

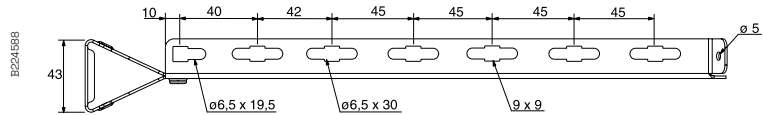

Widths = 400

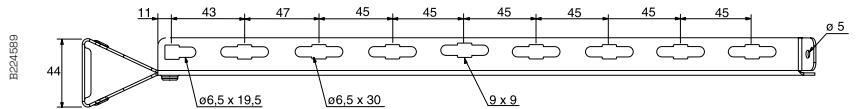

Widths = 500

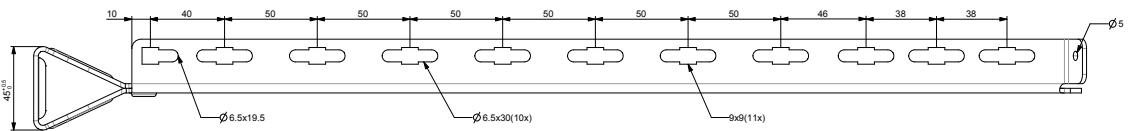

Widths = 600

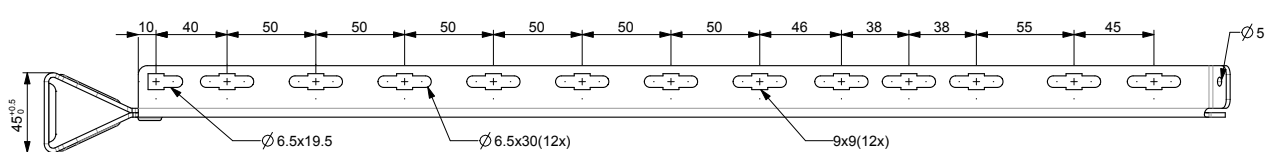

Technical information

Use and installation

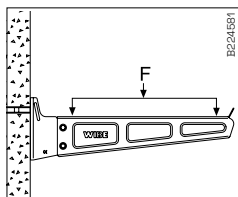

Installation of cantilever arm mounted to wall using Expansion bolt M8. Breaking load - See table below.

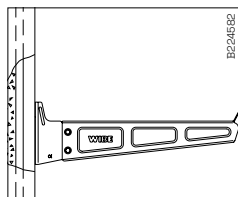

Installation of cantilever arm using T-bolt M8 on Fixing rail 24/26 x 53 for casting-in or Pendant/Fixing rail wall mounted.

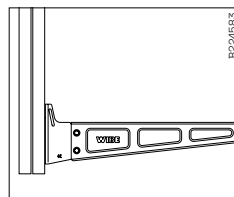

Installation of cantilever arm using T-bolt M8 on vertical piece. Check breaking load of the vertical piece.

Breaking load F - Mounted on wall

Type	KN	kg
50i-100	2.30	230
50i-200	2.15	215
50i-300	2.20	220
50i-400	2.35	235
50i-500	3.0	300
50i-600	3.0	300

Safe working load according to IEC 61537 is breaking load divided by 1,7.

Back plate 40

Back plate to be used for installation behind Cantilever arm 50 to reduce the surface pressure on porous walls.

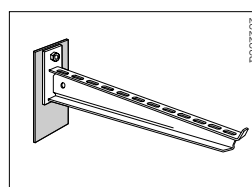
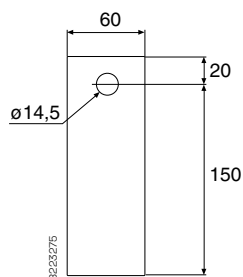

Mount Back plate 40 as shown in the illustration to reduce the surface stress on porous walls.

Technical information

Use and installation

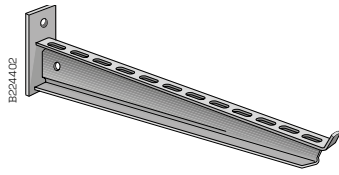

Cantilever arm 50

Cantilever arm for mounting on walls, pendant/fixing rails or vertical pieces.
Material: Steel, hot-dip galvanized.

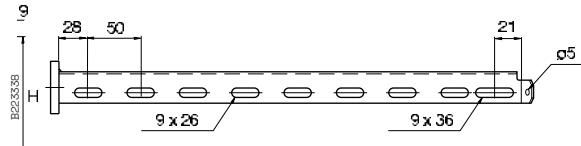
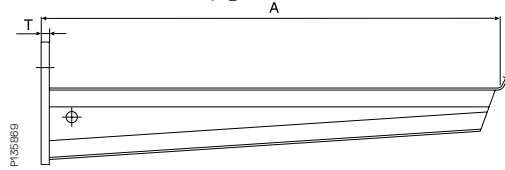

50/100-300

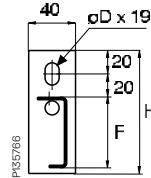

50/400-

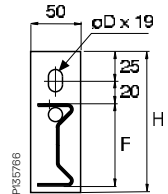

50/700-1000

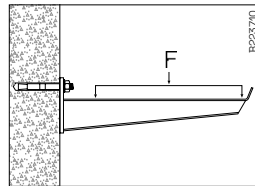
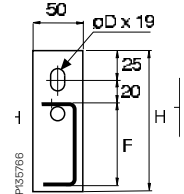

Installation of a Cantilever arm 50 to a wall using an Expansion bolt. Breaking load F, see table below.

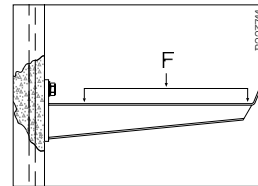

Installation of a Cantilever arm 50 using a T-bolt on pendant/fixing rail mounted on the wall. Breaking load F, see table below.

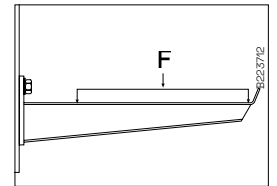

Installation of Cantilever arm 50 using T-bolt with vertical piece. Breaking load F, see table below. Also check the breaking load of vertical pieces.

Size and Breaking load F

Type	A mm	D mm	F mm	H mm	T mm	Mounted on wall		Mounted on P/F rail 24/48 with T-bolt 26U	
						kN	kg	kN	kg
50/100	150	12	34	85	3	3.0	300	3.0	300
50/150	200	12	36	85	3	3.0	300	3.0	300
50/200	250	12	39	85	3	2.5	250	2.5	250
50/300	350	12	60	105	6	4.0	400	3.0	400
50/400	450	12	70	120	8	6.5	650	4.5	650
50/500	550	12	77	140	8	7.0	700	4.5	700
50/600	650	12	84	150	10	7.0	700	4.0	700

Technical information

Use and installation

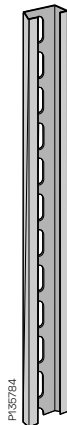

Pendant/Fixing rail 24/34

Pendant/Fixing rail for mounting of support brackets, cantilever arms, etc.

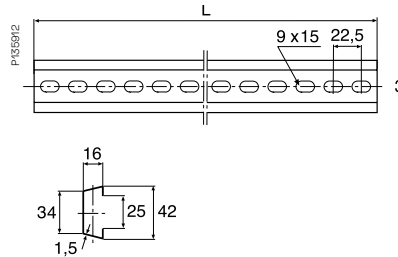

Type	L ± 2 mm
Pendant/Fixing rail 24/34	292.5
Pendant/Fixing rail 24/34	382.5
Pendant/Fixing rail 24/34	495.0
Pendant/Fixing rail 24/34	697.5
Pendant/Fixing rail 24/34	990.0
Pendant/Fixing rail 24/34	2970.0

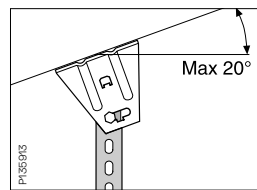

Ceiling bracket 5 and 1 Screw set 22S together provide a vertical piece that can be mounted with up to 20° slope.

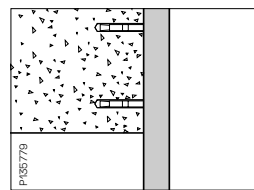

Side mounting of pendant/ fixing rails may be done using 2 Expansion bolts alt. 2 Concrete screws.

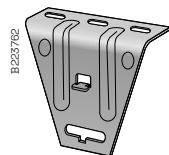

Ceiling bracket 5

Ceiling bracket to be used for installations with Pendant/Fixing rails 24/34 and 24/48. Screw not included.

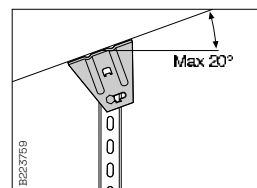
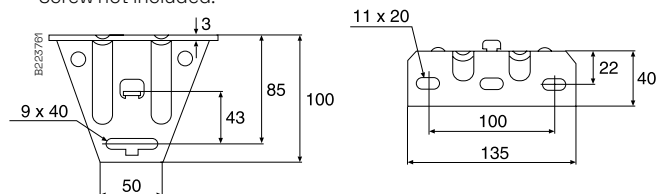

Using Pendant/Fixing rail 24/34 or 24/48, 1 Ceiling bracket 5 and 1 Screw set 22S it is possible to make a vertical piece that can be installed at an angle of up to 20°. Breaking load for rail 34 = 1000 kg (10 kN). Breaking load for rail 48 = 1200 kg (12 kN).

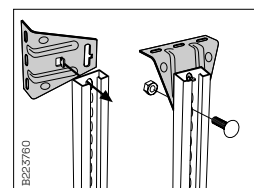

Mount Ceiling bracket 5 to the back of the pendant/ fixing rail by turning the ceiling bracket 90° and inserting the tab into the hole in the rail. Then turn the ceiling bracket back and lock it in the required position using 1 Screw set 22S. When mounting it at a horizontal ceiling, lock the screw in the slot recess for better lateral stability. Ceiling bracket 5 can be tilted max. 20°.

Technical information

Use and installation

Vertical piece 2

Vertical piece to be used for installation of Support bracket W1940/W1960, symmetrical loading. Can be joined to Pendant/fixing rail 24/34 with Pendant joint 2J.

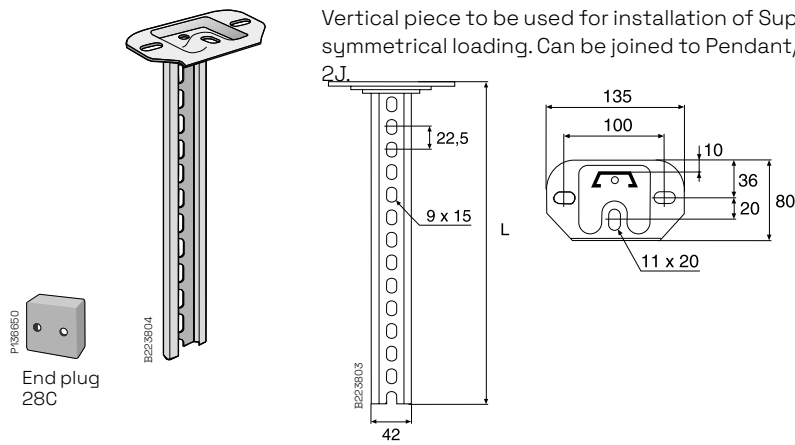

Type	L mm
Vertical piece 2/300	279
Vertical piece 2/400	392
Vertical piece 2/500	504
Vertical piece 2/700	729
Vertical piece 2/1000	1022

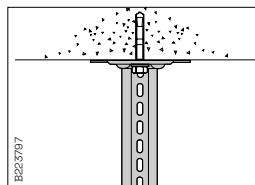

Mount Vertical piece 2 using an Expansion bolt or a concrete screw.

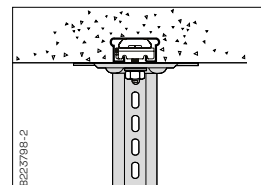

Mount Vertical piece 2 on a Fixing rail 24/26x53 for casting-in using T-bolt 26U.

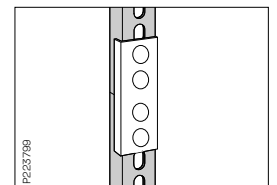

Vertical piece 2 can be joined to achieve the required length using Pendant/Fixing rail 24/34 and Pendant joint 2J.

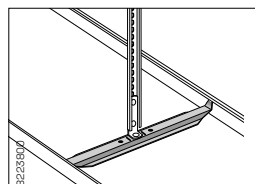

Support bracket W1940/W1960 can be mounted on Vertical piece 2 with Angle bracket W8. Use Screw set W36/W36C.

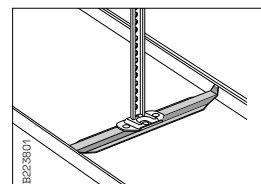

Support bracket W1940/1960 mounted in the fixing plate of the vertical piece with Screw set W36/W36C.

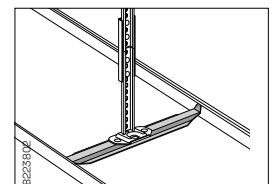

Use Pendant joint 2J to join two Vertical pieces 2.

Technical information

Use and installation

Vertical piece 2F

Vertical piece to be used for installation of Internal cantilever arm W17/40, Adjustable cantilever arm W18/40 or Cantilever arm 50/50L. Can be joined to Pendant/fixing rail 24/48 with Pendant joint 2FJ.

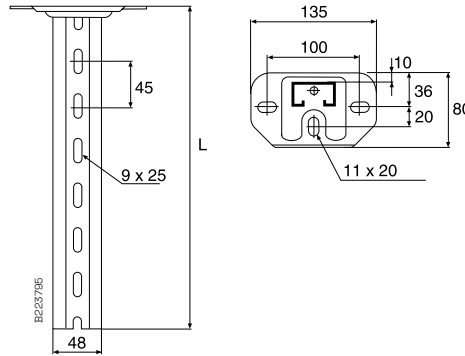
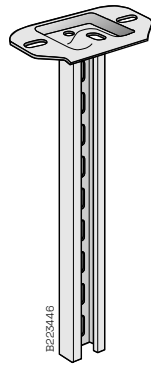

Type	L mm
Vertical piece 2F/280	280
Vertical piece 2F/370	370
Vertical piece 2F/505	505
Vertical piece 2F/730	730
Vertical piece 2F/1000	1000
Vertical piece 2F/1500	1495

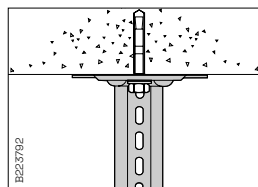

Mounted in ceiling with Expansion bolt alt. Concrete screw.

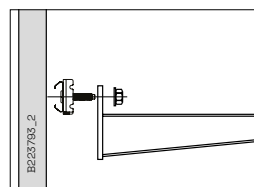

Cantilever arm 50 is mounted with a T-bolt.

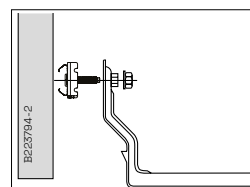

Internal cantilever arm W17/40 is mounted with a T-bolt.

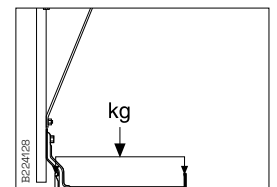

In order to reduce the deflection of Vertical piece 2F for heavy loads on Internal cantilever arm W17/40 and Adjustable cantilever arm W1840/W1860, Pendant bar 1 is installed.

End plugs

End plug to be mounted on pendant ends to provide protection against personal injury and to make the ends of the profiles more conspicuous.

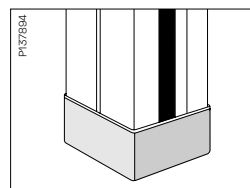
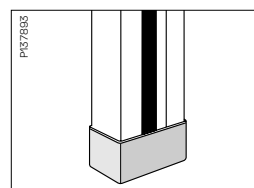
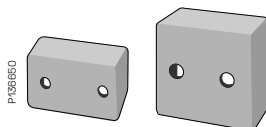

Technical information

Use and installation

Pendant bar 1

Pendant bar to be installed in order to reduce the deflection of heavily loaded vertical pieces. Installed with T-bolt and Expansion bolt.

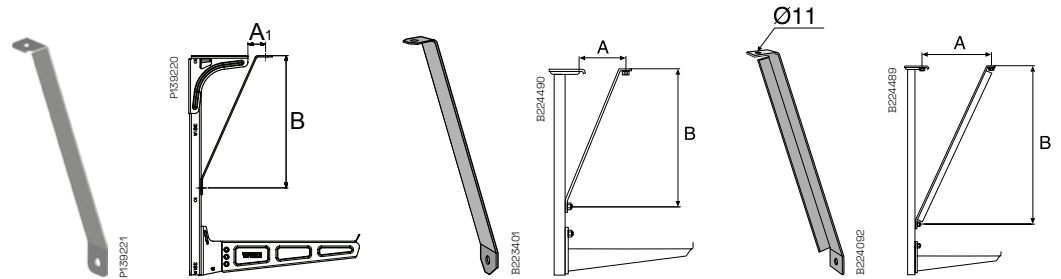

Pendant bar 1/300-800 Pre-galv.

Pendant bar 1/300-800 Hdg

Pendant bar 1-1500 Hdg

Type	A' mm	A mm	B mm
1/300	40	80	300
1/500	40	130	500
1/800	125	215	800
1/1500	Varies	Varies	Varies

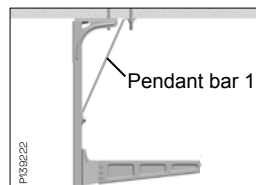

To reduce deflection of Vertical piece 2Fi at heavy loads on Cantilever arm 50i the Pendant bar 1 can be used. Install with T-bolt and Expansion bolt.

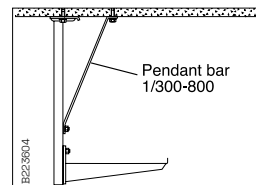

To reduce deflection of Vertical piece 2F at heavy loads on Cantilever arm 50 the Pendant bar 1 can be used. Install with T-bolt and Expansion bolt.

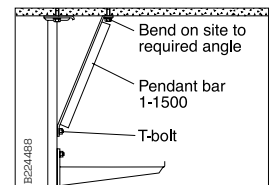

Mount this stay to reduce deflection of long Vertical pieces 2F.

Pendant joint 2J, 2FJ

Pendant joint to be used for joining pendant/fixing rails and vertical pieces.

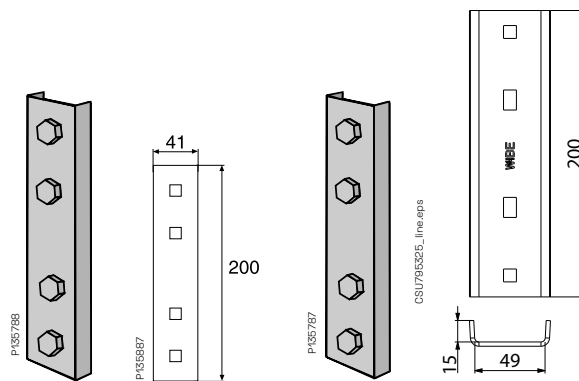

Pendant joint 2J

Pendant joint 2FJ

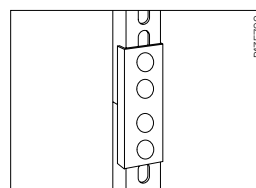

Pendant joint 2J, used for joining of Vertical piece 2 and Pendant/ Fixing rail 24/34.

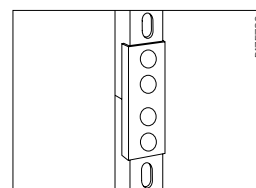

Pendant joint 2FJ, used for joining of Vertical piece 2F, Pendant Fixing rail 24/48 and CLX³ Pendant Fixing rail 24/48..

Technical information

Use and installation

Bracket 60/40

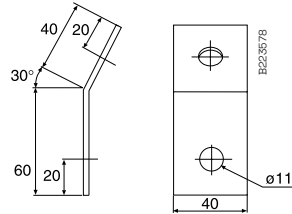
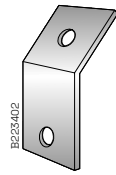

Bracket to be used together with Pendant/fixing rail 24/34 to reduce the deflection of long vertical pieces.

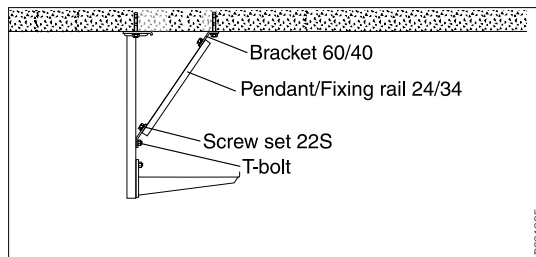

Use Bracket 60/40 with Pendant/ Fixing rail 24/34 to reduce the deflection of long pendants. Cut the pendant/fixing rail to a suitable length on site.

Pendant strip W33

Pendant strip to be used as a light-duty vertical ceiling suspension. The pendant strip is delivered in a straight length of 1 m, to be bent on site. Pendants longer than 1 m are joined by overlapping, using Screw set W36/W36C.

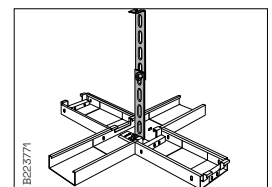
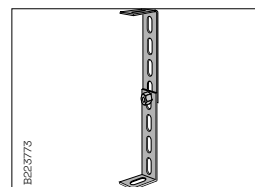
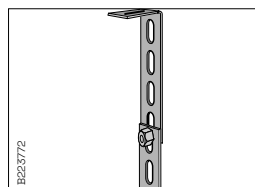
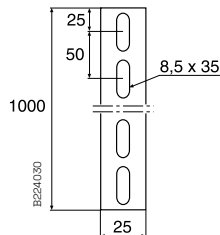
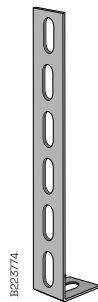

The Pendant strip W33 is delivered straight. Can be bent on site. Pendants longer than 1 m are joined by overlapping using Screw set W36/W36C.

If adjustment of pendant length is required this can be achieved by cutting the strip in the middle and overlapping the two parts so that a joint can be achieved using Screw set W36/W36C.

Mounted in open intersections for ceiling installation. Mounted with Screw set W36/W36C in Support bracket/joint W7.

Technical information

Use and installation

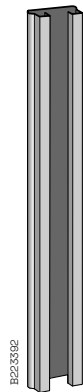

Fixing rail 24/26x53 for casting-in

Fixing rail for casting-in in wall and ceilings.

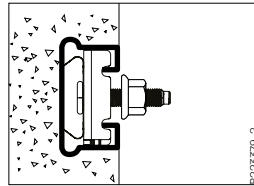
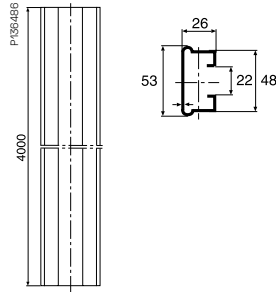

Fixing rail 24/26 x 53 for casting-in in walls and ceilings. Mount cantilever arms with T-bolt 26U.

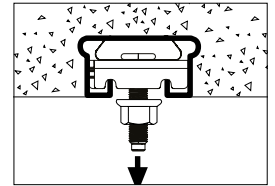

Max. pull-out load: 1000 kg/0.5 m of casting-in fixing rail (Concrete class K200).

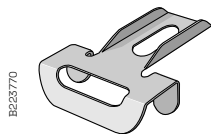

Locking clamp W77

Locking clamp to be used when pendant rail W32 is mounted between two parallel lighting trunking W70 or cable trays W1/W3 for additional stability.

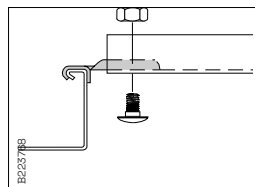
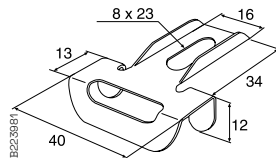

Pendant rail W32 mounted with Screw set W36/W36C or W34.

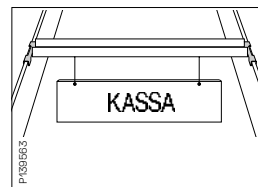

Locking clamp W77 used when Pendant rail W32 is mounted between two Lighting trunking W70 or cable trays as a stabilizer.

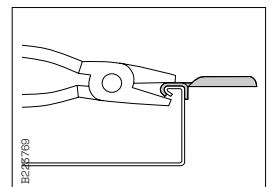

Locking clamp W77 fixed to the fold of trunking/tray with a pair of pliers.

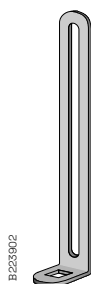

End bracket WN17

Used as vertical piece, for example mounted on Support bracket/joint W7 to achieve an concealed suspension.

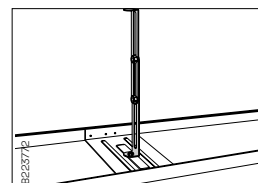
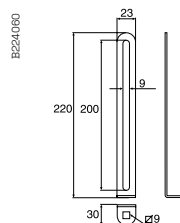

End bracket WN17 can be mounted as vertical piece on Support bracket/joint W7, use Screw set W36/W36C. The end brackets are joined with 2 Screw sets 22S. Max symmetrical load on the end bracket is 100 kg at tightening torque of 10.4 Nm.

Technical information

Use and installation

Angle bracket W8

Angle bracket to be mounted inside a cable tray W1/W3 for horizontal installation to the wall or vertical installation to the floor. Can also be mounted as a pendant bracket in the lighting trunking W70.

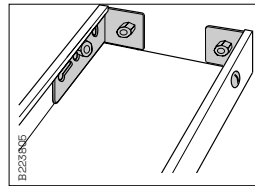
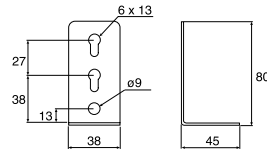
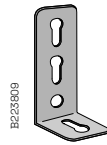

2 Angle brackets W8 are mounted in Cable trays W1/40 or W3/40 using 2 Screw sets W38P for horizontal connection to wall and vertical connection to floor. Can be mounted with legs pointing inwards or outwards.

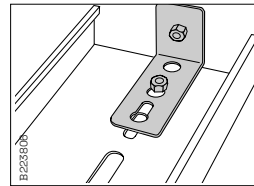

Angle bracket W8 mounted in bottom of lighting trunking with Screw set W36/W36C. Expansion bolts are used for installation in concrete walls. In sheet metal walls mounting is achieved with an Ogebe fixing type ED.

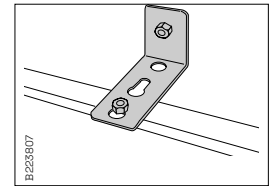

The Angle bracket W8 is mounted to achieve clearance from wall or where there is a large asymmetric load on the tray at pendant installation. Mounted at a distance of 1.5-2 m.

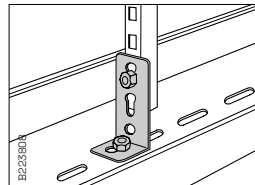

Angle bracket mounted in bottom of lighting trunking with Screw set W36/W36C as pendant attachment.

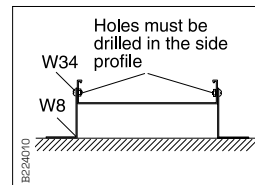

Horizontal installation of Cable tray W3/W1 on floor or vertically on wall. The angle bracket W8 can be turned to reduce the distance to floor or wall.

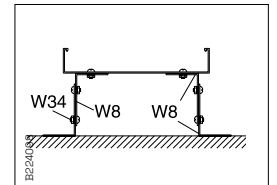

Horizontal installation of Cable tray W3 on floor or vertically on wall. The angle bracket W8 can be turned to reduce the distance to floor or wall.

Technical information

Use and installation

Angle bracket W8S

Universal angle bracket to be used for various installations of pendant/fixing rail 24/34, support bracket, etc.

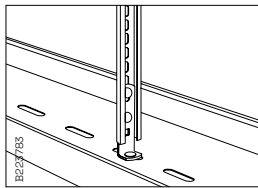
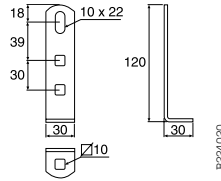
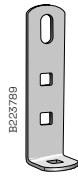

Vertical piece 2 or Pendant/Fixing rail 24/34 can be mounted with Angle bracket W8S directly into the lighting trunking. Use Screw set 22S.

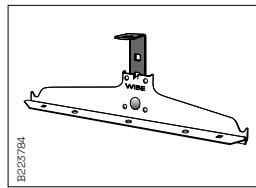

Support bracket 3 can be mounted in ceilings with Angle bracket W8S and Screw set 22S.

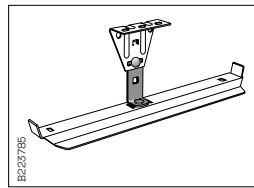

Support bracket W1940/W1960 can be mounted on Ceiling bracket 5 with Angle bracket W8S and Screw set 22S.

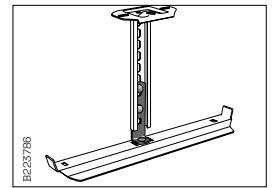

Support bracket W1940/W1960 can be mounted on Vertical piece 2 with Angle bracket W8S and Screw set 22S.

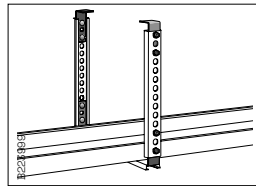

Clamp suspension of cable tray can be made with Pendant/Fixing rail 24/34, Angle bracket W8S and Screw set 22S.

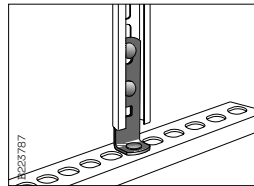

Angle bracket W8S can be used for installations in Pendant/Fixing rail 24/34. Use Screw set 22S.
An easy way to build stands for electrical cabinets.

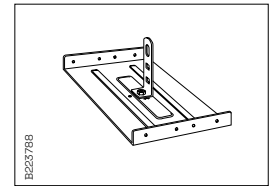

Support bracket/joint W7 can be mounted directly on Vertical piece 2 with Angle bracket W8S and Screw set 22S. Does not apply to widths used for joining only.

Technical information

Use and installation



Lashing wire

Lashing wire to be used for lashing of cables on mounting rails or cable ladders.

Type		Diam mm	Breaking load kg
HTR - 2303	Lashing wire, stainless steel, white PVC	1.25	92
HTR - 2313	Lashing wire, stainless steel, black PVC	1.25	92
HT - 2304	Lashing wire, white PVC	1.5	25
HT - 2314	Lashing wire, black PVC	1.5	25

Technical information

Use and installation

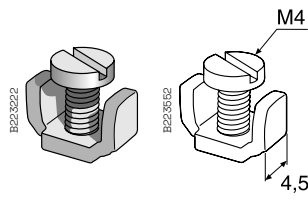

Earth clamp W79

The earth clamp is used when protective earthing of the junction box plate is

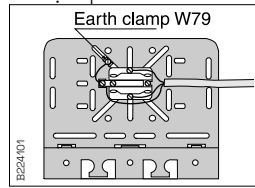

Earth clamps are designed for use when protective earthing of the mounting plate is required for mounting apparatuses as per relevant heavy current directives. The oblong holes in the junction box plate (mounting plate) permit movement of the earth clamp so that it always comes under the casing of the apparatus. If the apparatus's earth clamp is not approved for joining protective earth conductors, it must pass unbroken through the apparatus's earth clamp to the junction box earth clamp (see the fig.).

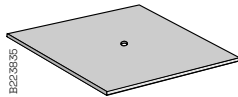

Cover plate W16

Cover plate to be used to level out the differences in level between cable tray and junctions, such as 90° bends, T- and X-junctions. To be mounted under the junctions.

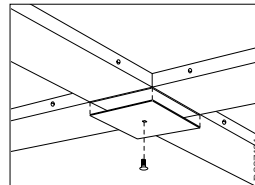
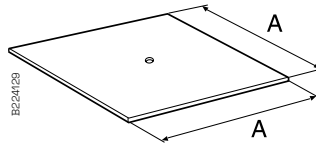

Mounted with Screw set W36/W36C under X-junction W13/40 if one needs to level out differences in height between tray and bend.

Type	A mm
Cover plate W16-70	70
Cover plate W16-100	100
Cover plate W16-200	200
Cover plate W16-300	300
Cover plate W16-400	400

Technical information

Use and installation

Strip fixing W44

The Strip fixing W44 enables strapping of cables in an unperforated tray.

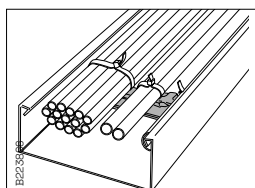
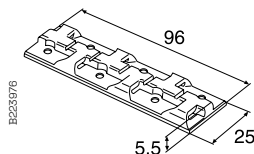
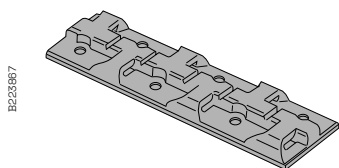

The Strip fixing W44 is provided with double sided adhesive tape and is attached to the tray bottom. Alternatively, blind rivets or self-tapping screws can be used.

When mounting with double sided adhesive tape, the surface on the tray bottom must be wiped clean. Loads may not be applied until after 24 hours. Full adhesion is obtained after 72 hours in 21°C.

Ideal application temperature is 21°-38°C.

Application below normal room temperature not recommended.

Each Strip fixing W44 can be split up in 2 to 6 pieces. Supplied with 50 pieces in a plastic bag.

Protection strip W48

Used to protect the cables from damage.

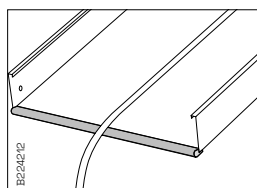
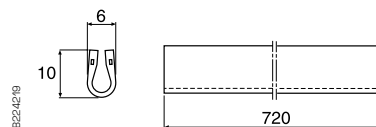
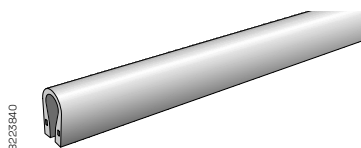

When cutting a cable tray you can mount Protection strip W48 to protect the cables from damage.

Technical information

Use and installation

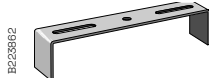

BP2386C2

Luminaire bracket W50

Luminaire bracket to be used to mount lighting fixtures between two parallel Cable trays W1/W3 or Lighting trunking W70. Dimension A (* height) is specified when ordering and is depending on the height of the lighting fixture.

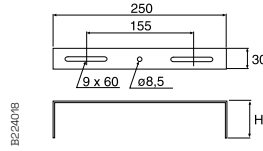

BP2401B

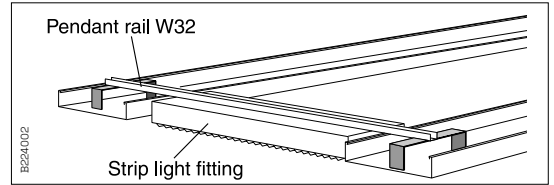

BP24002

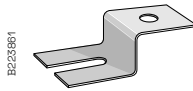

BP23861

Luminaire bracket W35

Luminaire bracket to be used to fix centralized lighting fixtures under Lighting trunking W70.

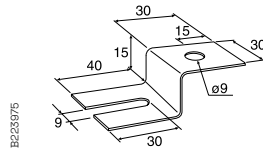

BP23975

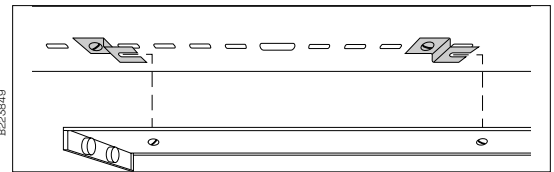

BP23849

Mounted in the rail's module holes with Screw set W36/W36C or W34. Note! The fork openings must be mounted in the same direction.

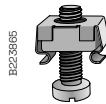

BP23865

Luminaire bracket W55

Luminaire bracket to be used to mount lighting fixtures under Lighting trunking W70.

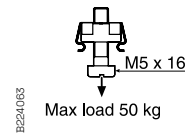

BP24063

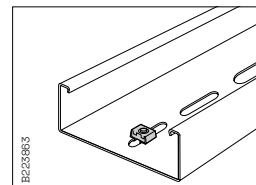

BP23863

Mounted in the mounting holes in Lighting trunking W70.

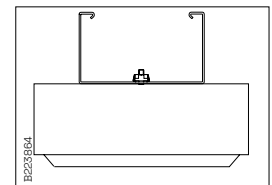

BP23864

Always mount the Luminaire bracket W55 from above so that it rests in the tray.

Technical information

Use and installation

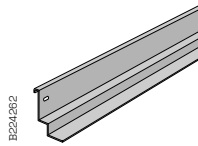

B224362

Shade ledge W26/40

Shade ledge to be used as a support for ceilings mounted between cable trays with system height 40 mm. Suspended over the lateral side of the cable tray. Also suitable for Lighting trunking W70.

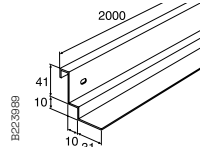

B223688

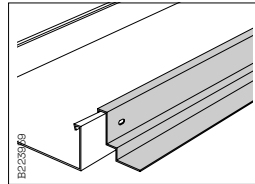

B223689

Shade ledge W26/40 is hung over the side edge of the cable tray.

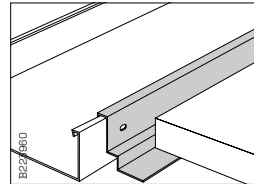

B223690

Shade edge W26/40 is used as a support for ceilings mounted between cable trays. Also suitable for Lighting trunking W70. Mounted along the side edges of the cable tray or the lighting trunking.

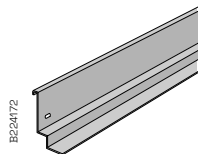

B224172

Shade ledge W26/60

Shade ledge to be used as a support for ceilings mounted between cable trays with an edge height of 60 mm. Suspended over the lateral side edge of the cable tray.

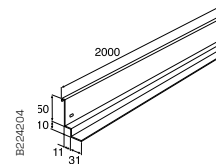

B224204

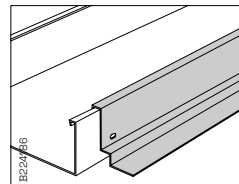

B223686

Shade ledge W26/60 is hung over the side edge of the cable tray.

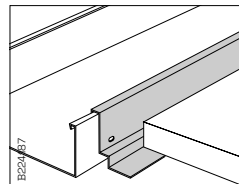

B224167

Shade edge W26/60 is used as a support for ceilings mounted between cable trays. Mounted along the side edges of the cable tray.

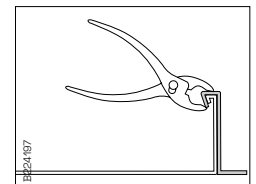

B224167

Shade list W26/40 and W26/60 can be locked tight in the tray by pinching the ends in under the tray edge with pliers.

Technical information

Use and installation

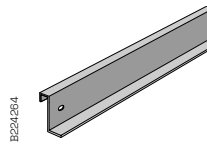

Integrated ceiling support channel W27/40

Integrated support channel to be used as a support for false ceilings mounted between cable trays with system height 40 mm. Suspended over the lateral side of the cable tray. Also suitable for Lighting trunking W70.

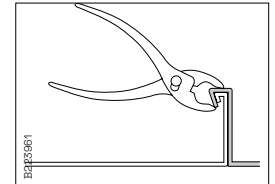
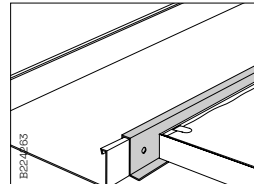
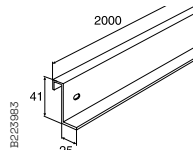

Integrated ceiling support channel W27/40 is hung over and mounted along the side edge of the cable tray and is used as a support for ceilings mounted between cable trays. Also suitable for Lighting trunking W70.

Integrated ceiling support channel W27/40 is locked tight in the tray by pinching the ends in under the tray edge with pliers.

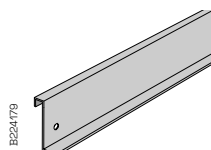

Integrated ceiling support channel W27/60

Integrated support channel to be used as a support for false ceilings mounted between cable trays with system height 60 mm. Suspended over the lateral side of the cable tray.

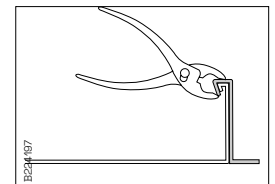
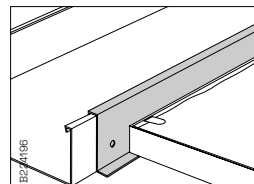
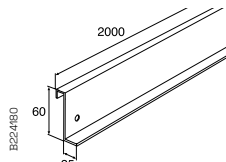

Integrated ceiling support channel W27/60 is used as a support for ceilings mounted between cable trays. Mounted along the side edge of the cable tray.

Integrated ceiling support channel W27/40 and W27/60 can be locked tight in the tray by pinching the ends in under the tray edge with pliers.

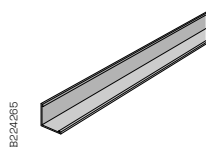

Angle strip W46

Angle strip to be used as a support for installations of false ceilings. To be mounted directly onto a wall, or to the construction of the building.

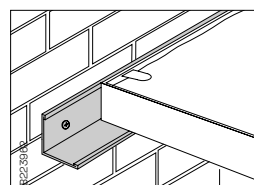
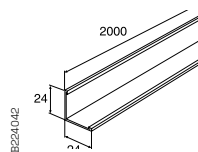

Angle strip W46 is mounted directly onto wall, column or similar as a support for baffles or ceiling lamina.

Technical information

Use and installation



T-bolt 26U

T-bolt to be used for mounting with all vertical pieces (except Vertical piece 2) and with Pendant fixing rail 24/48.

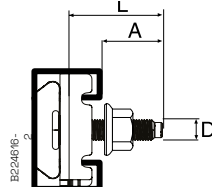

Type	L mm	A mm
M8	34	23
M10	34	23
M10	44	33
M10	54	43

Max permitted extraction force

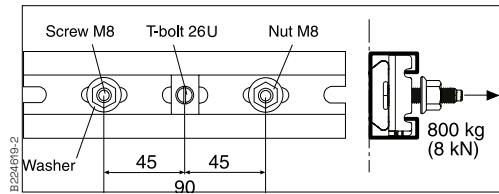

T-bolt 26U M8/M10 + P/F-rail 24/48 + Washer 8.4x19x1.5

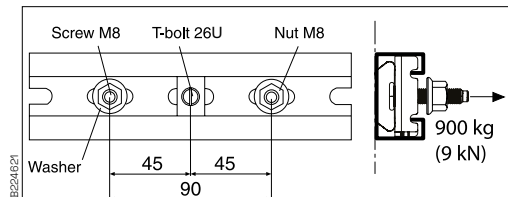

T-bolt 26U M8 + P/F-rail 24/48 + Washer 9x35x2

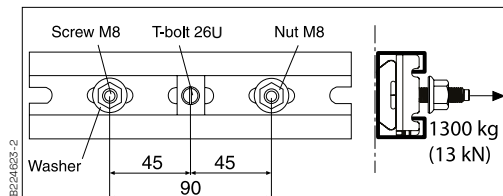

T-bolt 26U M10 + P/F-rail 24/48 + Washer 9x35x2

Technical information

Use and installation

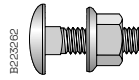

Screw set 22S

Screw set to be used for installation of Ceiling bracket 5 on Pendant/fixing rails 24/34 and 24/48, Angle bracket 5L against the back of Pendant/fixing rails, Pendant/fixing rails back to back. Set including screw MVBF 8x16 and nut M6MF8.



Screw set W34

Screw set to be used for mounting of Angle bracket W8 onto Pendant rail W32 and for joining of W4 Installation trays. Set including screw MSCS 6x12 and nut M6MF6.



Screw set W36

Screw set including bolt and nut M8 to be used for the mounting of single Pendant attachment W21 or on Support bracket/jointW7.



Screw set W36C

Screw set including bolt with slotted screw head and nut M8. To be used for the mounting of single Pendant attachment W21 or Tube pendant attachment W73 on Support bracket/joint W7.

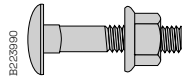

Screw set W37

Screw set including bolt MVBF 8x35 and nut M6MF 8, to be used for assembly of Pendant attachment W21 and Ceiling attachment W31 with Pendant rail W32, and for the joining of Pendant rail W32.

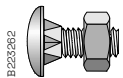

Screw set W38P

Screw set including screw and nut, to be used for the mounting of joints, bends, junctions, shade ledge W26 and integrated ceiling support channel W27. The patented screw set pierces through painted surfaces securing potential balancing. N.B. The joints must be unpainted.



Screw W40

For locking of T-joint W29 in open junctions.



T-bolt 26U

T-bolt to be used for mounting with all vertical pieces (except Vertical piece 2) and with Pendant fixing rail 24/48.

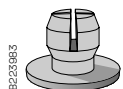

Locking plug W41

Locking plug to be used for quick locking of joints, bends and branches in cable trays and lighting trunking.

Reference number overview

70	717205.....70	723226.....25	726666.....18	729152.....44
705093.....62	717637.....35, 63	723227.....25	726667.....18	729154.....44
709021.....35, 63, 72, 77	717640.....62	723228.....25	726873.....63	729155.....44
71	717641.....62	723229.....25	726874.....53	729156.....44
713153.....61	717642.....62	723230.....25	726875.....77	729157.....44
713177.....62	717643.....72	723231.....25	728071.....34	729158.....44
713178.....62	717644.....72	723232.....25	728595.....76	729177.....46
713251.....18	717645.....72	723432.....60	728883.....63	729178.....46
713252.....18	717903.....23	723433.....60	728986.....38	729179.....46
713254.....18	717904.....23	723434.....60	728987.....38	729180.....46
713256.....18	717905.....23	723436.....60	728988.....38	729181.....46
713257.....18	717906.....23	723437.....60	728989.....38	729182.....46
713258.....18	717907.....23	723438.....60	728990.....38	729183.....46
713684.....35, 63, 73	717908.....24	723439.....60	728991.....38	729184.....47
713685.....35, 63, 73	717909.....24	723440.....69	728992.....38	729185.....47
713686.....35, 63, 73	717910.....24	723441.....69	729015.....40	729186.....47
713687.....35, 63, 73	717911.....24	723442.....69	729016.....40	729187.....47
713694.....58, 68	717912.....24	723444.....69	729017.....40	729188.....47
713911.....27	717913.....24	723445.....69	729018.....40	729189.....47
713912.....27	717914.....24	723446.....69	729019.....40	729190.....47
713913.....27	717915.....24	723447.....69	729020.....40	729191.....47
713914.....27	717916.....24	723938.....59, 69	729021.....40	729192.....48
713916.....27	717917.....24	723974.....18	729027.....51	729193.....48
713917.....27	717950.....40	723975.....18	729028.....51	729201.....43
713918.....27	717990.....28	723976.....18	729029.....52	
714029.....70	717995.....27	723977.....18	729030.....52	
715646.....29, 49	718036.....24	724806.....30, 50	729031.....52	73
715650.....28, 47	718037.....24	724807.....75	729032.....52	730186.....20, 40, 54, 65
715879.....61	718038.....24	724942.....42	729033.....52	730191.....55
716283.....70	718039.....24	724943.....42	729034.....52	730247.....27
716284.....70	718040.....24	724944.....42	729041.....51	731717.....34
716285.....70	718193.....27	724945.....42	729042.....51	731719.....62
716286.....70	718205.....22	724946.....42	729043.....51	731721.....34
716287.....70	718360.....32	724947.....42	729044.....51	731724.....71
716293.....71	718361.....32	724948.....42	729045.....70	731727.....76
716295.....71	718445.....21	724965.....23	729046.....41	731730.....26
716303.....72	718446.....21	724966.....23	729047.....41	731731.....26
716304.....72	718447.....21	724969.....30, 50	729048.....41	731732.....26
716306.....71	718448.....21	725083.....30, 50	729049.....41	731733.....26
716309.....71	718469.....35, 53, 63, 73	725084.....75	729050.....41	731734.....26
716407.....59, 68	718473.....29, 49	725085.....59, 69	729051.....41	731735.....26
716474.....31, 51	718556.....28	725357.....34	729052.....41	731736.....26
716630.....34	718559.....28	725358.....34	729054.....53	731747.....55
716634.....30	718640.....61	725359.....34	729055.....50	731963.....27
716640.....27, 47	718645.....49, 59, 68	725360.....34	729058.....53	731964.....47
716792.....30	718645.....29	725361.....34	729059.....53	732177.....33
716793.....30	718711.....31	725362.....33	729060.....48	732214.....20
716797.....28	718828.....20, 41	725557.....76	729061.....50	732215.....20
716798.....34	718829.....20, 41	725558.....76	729062.....50	732216.....20
716799.....29	718830.....20, 41	725559.....76	729063.....53	732217.....20
716799.....49	718831.....20, 41	725560.....76	729066.....53	732218.....20
716816.....33	718832.....20, 41	725561.....76	729068.....42	732219.....20
716821.....34	718833.....20, 41	725562.....76	729094.....43	732220.....20
716824.....20, 40, 55	718834.....20, 41	725563.....76	729103.....42	732221.....20
716833.....23	718835.....20	725564.....76	729104.....43	732262.....54
716834.....23	718835.....20	725565.....76	729105.....43	732263.....54
716835.....23	718903.....62	725566.....76	729106.....43	732264.....54
716836.....23	718904.....62	725573.....76	729107.....43	732265.....54
716837.....23	72	725574.....76	729108.....43	732266.....54
716911.....32	720520.....28	725575.....76	729109.....43	732267.....54
716912.....32	720530.....72	725576.....76	729126.....45	732268.....54
716913.....32	720531.....72	725577.....76	729127.....45	732269.....54
716914.....32	720785.....47	725578.....76	729128.....45	732983.....55
716914.....32	720822.....18	725579.....76	729129.....45	733090.....33
717001.....60	720825.....21	725580.....77	729130.....45	733480.....23
717021.....21	720970.....31	725581.....75	729131.....45	733485.....24
717022.....21	720973.....31	725582.....75	729132.....45	733486.....53
717023.....21	720979.....28, 48	725583.....76	729133.....43	733487.....61
717024.....21	720984.....18	725584.....76	729134.....43	733498.....25
717069.....59, 69	720985.....18	725585.....77	729135.....43	733499.....25
717191.....61	720985.....18	725586.....75	729136.....43	734101.....45, 57
717192.....61	720990.....21	725589.....75	729137.....43	734102.....57
717193.....61	721101.....33	725618.....75	729138.....43	734103.....57
717194.....61	721102.....34	725619.....75	729139.....44	734104.....57
717195.....61	721180.....31	725620.....75	729140.....44	734105.....57
717196.....61	721184.....23	725622.....75	729141.....44	734106.....57
717197.....61	721186.....24	725623.....75	729142.....44	734107.....57
717198.....61	721188.....24	725624.....75	729143.....44	734108.....57
717199.....61	721786.....33	725625.....75	729144.....44	734109.....57
717200.....61	721868.....29, 49	725625.....75	729145.....44	734134.....40
717201.....70	721943.....31	725785.....20	729146.....44	734211.....47
717202.....70	723180.....21	725786.....40	729147.....44	734227.....27
717203.....70	723196.....23	726484.....77	729148.....44	734228.....47
717204.....70	723198.....24	726485.....77	729149.....44	734401.....31
	723200.....24	726664.....18	729150.....44	734402.....31
	723219.....18	726665.....18	729151.....44	734403.....31

Reference number overview

734452.....	59	736616.....	54	782217.....	22	782430.....	44	783063.....	69
734453.....	59	736617.....	54	782218.....	42	782431.....	44	783064.....	69
734454.....	59	736618.....	54	782267.....	21	782440.....	44	783065.....	69
734455.....	59	736619.....	54	782268.....	23	782441.....	44	783066.....	70
734456.....	59	736620.....	54	782269.....	23	782442.....	44	783067.....	70
734457.....	59	736633.....	39	782270.....	23	782443.....	44	783068.....	70
734554.....	21	736634.....	39	782271.....	23	782444.....	44	783069.....	70
734555.....	21	736635.....	39	782272.....	23	782445.....	44	783107.....	71
734572.....	60	736636.....	39	782273.....	23	782446.....	44	783120.....	71
734573.....	60	736637.....	39	782274.....	23	782447.....	44	783122.....	71
734574.....	60	736638.....	39	782275.....	23	782458.....	23	783124.....	72
734575.....	60	736639.....	39	782276.....	25	782459.....	23	783126.....	72
734578.....	60	736640.....	39	782277.....	25	782460.....	24	783128.....	65
734579.....	60	737537.....	39	782278.....	25	782461.....	24	783130.....	68
734580.....	60	737538.....	39	782279.....	25	782462.....	24	783166.....	51
734581.....	60	737539.....	39	782280.....	25	782463.....	24	783167.....	51
734582.....	60	737540.....	39	782281.....	25	782471.....	43	783168.....	51
734583.....	60	737541.....	39	782282.....	25	782472.....	43	783169.....	51
734584.....	23	737542.....	39	782283.....	25	782473.....	43	783170.....	51
734585.....	23	737543.....	39	782284.....	27	782474.....	43	783171.....	51
734591.....	56	737544.....	39	782285.....	27	782475.....	43	783178.....	22
734592.....	56	737545.....	39	782286.....	27	782476.....	43	783179.....	22
734593.....	56	739713.....	53, 73	782287.....	27	782477.....	43	783180.....	22
734594.....	56			782288.....	27	782478.....	43	783181.....	22
734595.....	56			782289.....	27	782593.....	45	783182.....	22
734596.....	56	76		782290.....	27	782594.....	45	783183.....	22
734597.....	56	768063.....	62	782292.....	26	782595.....	45	783184.....	22
734598.....	56	768738.....	60	782293.....	26	782596.....	45	783185.....	42
734599.....	56			782294.....	26	782597.....	45	783186.....	42
734617.....	58	78		782295.....	26	782598.....	45	783187.....	42
734618.....	62	781334.....	38	782296.....	26	782599.....	45	783188.....	42
734619.....	61	781335.....	38	782297.....	26	782600.....	45	783189.....	42
734620.....	61	781336.....	38	782298.....	26	782614.....	47	783190.....	42
734622.....	56	781337.....	38	782299.....	20	782615.....	47	783191.....	42
734646.....	58, 68	781338.....	38	782306.....	39	782616.....	47	783470.....	74
735177.....	29, 58, 68	781339.....	38	782307.....	39	782617.....	47	783471.....	74
735388.....	19	781340.....	38	782308.....	39	782618.....	47	783472.....	74
735389.....	19	781999.....	18	782309.....	39	782619.....	47	783473.....	74
735390.....	19	782000.....	18	782310.....	39	782620.....	47	783474.....	74
735391.....	19	782001.....	18	782311.....	39	782659.....	47	783475.....	74
735392.....	19	782011.....	38	782318.....	41	782661.....	48	783476.....	74
735393.....	19	782012.....	38	782319.....	41	782662.....	48	783477.....	74
735394.....	19	782013.....	38	782320.....	41	782850.....	66	783487.....	74
735395.....	19	782014.....	38	782321.....	41	782851.....	66	783500.....	29, 49
735396.....	19	782015.....	38	782322.....	41	782852.....	66	783504.....	52
735400.....	54	782016.....	38	782323.....	41	782853.....	66	783505.....	52
735401.....	54	782017.....	38	782324.....	41	782854.....	66	783506.....	52
735402.....	54	782038.....	23	782325.....	41	782855.....	66	783507.....	52
735403.....	54	782039.....	23	782330.....	41	782856.....	66	783508.....	52
735404.....	54	782040.....	23	782332.....	31	782857.....	66	783509.....	52
735405.....	54	782041.....	23	782333.....	31	782858.....	66	783587.....	32
735406.....	54	782042.....	23	782334.....	31	783000.....	68	783588.....	32
735407.....	54	782043.....	23	782335.....	31	783001.....	68	783589.....	32
735408.....	54	782044.....	23	782336.....	31	783002.....	68	783590.....	32
735977.....	54	782045.....	23	782337.....	31	783003.....	68	783591.....	52
735978.....	54	782046.....	18	782342.....	31	783004.....	68	783592.....	52
735979.....	54	782047.....	18	782343.....	31	783005.....	68	783593.....	52
735980.....	54	782048.....	38	782344.....	31	783006.....	68	783594.....	52
735981.....	54	782049.....	38	782363.....	65	783007.....	68	783600.....	66
735982.....	54	782052.....	24	782365.....	65	783018.....	70	783601.....	66
735988.....	19	782053.....	24	782366.....	65	783019.....	70	783602.....	66
735989.....	19	782054.....	24	782367.....	65	783020.....	70	783603.....	66
735990.....	19	782055.....	24	782368.....	65	783021.....	70	783604.....	66
735991.....	19	782056.....	24	782369.....	65	783022.....	70	783605.....	66
735992.....	19	782057.....	24	782370.....	65	783023.....	70	783606.....	66
735993.....	19	782058.....	24	782371.....	65	783030.....	58	783607.....	66
735999.....	64	782059.....	24	782392.....	32	783031.....	58	783608.....	66
736000.....	64	782095.....	24	782393.....	32	783032.....	58	783620.....	66
736001.....	64	782096.....	24	782394.....	32	783033.....	58	783621.....	66
736002.....	64	782097.....	24	782395.....	32	783034.....	58	783622.....	66
736003.....	64	782098.....	24	782396.....	32	783035.....	58	783623.....	66
736004.....	64	782099.....	24	782397.....	32	783036.....	58	783624.....	66
736005.....	64	782100.....	24	782408.....	43	783037.....	58	783625.....	66
736006.....	64	782101.....	24	782409.....	43	783040.....	67	783626.....	66
736603.....	19	782102.....	24	782410.....	43	783041.....	67	783627.....	66
736604.....	19	782202.....	19	782411.....	43	783042.....	67	783628.....	66
736605.....	19	782203.....	19	782412.....	43	783043.....	67	783640.....	67
736606.....	19	782204.....	19	782413.....	43	783044.....	67	783641.....	67
736607.....	19	782205.....	19	782414.....	43	783045.....	67	783642.....	67
736608.....	19	782206.....	19	782415.....	43	783046.....	67	783643.....	67
736609.....	19	782207.....	19	782424.....	44	783047.....	67	783644.....	67
736610.....	19	782209.....	21	782425.....	44	783048.....	67	783645.....	67
736613.....	54	782210.....	21	782426.....	44	783060.....	69	783646.....	67
736614.....	54	782211.....	21	782427.....	44	783061.....	69	783647.....	67
736615.....	54	782212.....	21	782428.....	44	783062.....	69	783648.....	67
		782216.....	49	782429.....	44				

Reference number overview

783660.....	56	784101.....	57	791281.....	55	793674.....	67	CSU		
783661.....	56	784102.....	57	791282.....	65	793675.....	67		CSU734698.....	59, 69
783662.....	56	784103.....	57	791283.....	65	793676.....	67		CSU794123.....	20
783663.....	56	784104.....	57	791284.....	65	793677.....	66		CSU794124.....	20
783664.....	56	784105.....	45	791285.....	65	793678.....	66		CSU794125.....	20
783665.....	56	784106.....	45	791286.....	65	793679.....	66		CSU794184.....	40
783666.....	56	784107.....	45	791287.....	65	793680.....	66		CSU794185.....	40
783667.....	56	784108.....	45	791288.....	65	793681.....	66		CSU794186.....	40
783668.....	56	784109.....	45	791289.....	65	793682.....	66		CSU794528.....	54
783670.....	56	784110.....	45	791290.....	65	793683.....	66		CSU794529.....	54
783671.....	56	784111.....	45	791412.....	32	793684.....	66		CSU794531.....	64
783672.....	56	784112.....	45	791413.....	32	1149405.....	30, 50		CSU794532.....	64
783673.....	56	784113.....	43	791414.....	32	1149456.....	30, 50		CSU794532.....	64
783674.....	56	784114.....	43	791415.....	32	1149464.....	30, 50		CSU794697.....	59, 69
783675.....	56	784115.....	43	791416.....	52	1149466.....	30, 50		CSU794699.....	59, 69
783676.....	56	784116.....	43	791417.....	52	1149551.....	75		CSU794715.....	59, 69
783677.....	56	784117.....	43	791418.....	52	1149552.....	75		CSU795136.....	21, 55
783678.....	56	784118.....	43	791419.....	52	1149554.....	75		CSU795216.....	20
783680.....	57	784119.....	43	792554.....	33	1149561.....	75		CSU795217.....	40
783681.....	57	784120.....	43	792723.....	33	1149562.....	75		CSU795218.....	54
783682.....	57	786771.....	46	792724.....	33	1149564.....	75		CSU795219.....	64
783683.....	57	786772.....	46	792725.....	33				CSU795316.....	60
783684.....	57	786773.....	46	792726.....	33				CSU795317.....	60
783685.....	57	786774.....	46	792727.....	34				CSU795318.....	60
783686.....	57	786775.....	46	792728.....	34				CSU795319.....	60
783687.....	57	786776.....	46	792729.....	34				CSU795320.....	60
783688.....	57	786777.....	46	792934.....	30, 50				CSU795321.....	60
783753.....	51	786792.....	32	792935.....	30, 50				CSU795322.....	32
783754.....	51	786793.....	52	793571.....	26				CSU795323.....	32
783884.....	74	786831.....	18	793572.....	26				CSU795325.....	34
783885.....	74	786832.....	18	793573.....	26				CSU795328.....	77
783886.....	74	786833.....	38	793574.....	26				CSU795370 ...	32, 52, 60, 70
783887.....	74	786834.....	38	793575.....	26				CSU795371.....	32
783888.....	74	786837.....	21	793576.....	26				CSU795372.....	52
783889.....	74	786838.....	41	793577.....	26				CSU795377.....	32, 60
783890.....	74	786873.....	40	793578.....	26				CSU795378.....	52, 70
783891.....	74	787188.....	43	793579.....	46				CSU795379.....	23
783900.....	74	787189.....	43	793580.....	46				CSU795380.....	43
783901.....	74	787192.....	44	793581.....	46				CSU795381.....	56
783902.....	74	787193.....	44	793582.....	46				CSU795382.....	66
783903.....	74	787196.....	44	793583.....	46				CSU795383.....	24
783904.....	74	787197.....	44	793584.....	46				CSU795384.....	44
783905.....	74	787211.....	35, 53, 63, 73, 77	793585.....	46				CSU795385.....	56
783906.....	74	787227.....	39	793586.....	46				CSU795386.....	66
783907.....	74	787228.....	39	793587.....	58				CSU795387.....	24
783908.....	57	787229.....	39	793588.....	58			CSU795388.....	44	
783909.....	57	787230.....	39	793589.....	58			CSU795389.....	57	
783910.....	57	787231.....	39	793590.....	58			CSU795390.....	67	
783911.....	57	787232.....	39	793591.....	58			CSU795564.....	34	
783912.....	57	787276.....	61	793592.....	58			CSU795565.....	62, 71, 76	
783913.....	57	787277.....	70	793593.....	58			CSU795566.....	76	
783914.....	57	787278.....	76	793594.....	58			CSU795568.....	71	
783915.....	57	787436.....	26	793595.....	58			CSU795588.....	29, 49	
783916.....	57	787437.....	26	793596.....	58			CSU795589.....	59, 68	
784061.....	30, 50	787438.....	46	793597.....	67			CSU795590.....	59, 68	
784062.....	30, 50	787439.....	46	793598.....	67			CSU795591.....	59, 68	
784063.....	30, 50	787442.....	26	793599.....	67			CSU795592.....	75	
784073.....	23	787443.....	26	793600.....	67			CSU795593.....	75	
784074.....	23	787444.....	46	793601.....	67			CSU795594.....	29, 49	
784075.....	23	787445.....	46	793602.....	67			CSU795595.....	59, 68	
784076.....	23	788572.....	22	793603.....	67			CSU795596.....	75	
784077.....	23	788573.....	55	793604.....	67			CSU795597.....	63	
784078.....	23	788574.....	41	793605.....	67			CSU795632.....	37	
784079.....	23	788575.....	65	793606.....	67			CSU795633.....	37	
784080.....	23	789875.....	35, 63, 72, 77	793607.....	26			CSU795634.....	37	
784081.....	56			793608.....	26			CSU795635.....	37	
784082.....	56			793609.....	26			CSU795636.....	37	
784083.....	56	79		793610.....	26			CSU795637.....	37	
784084.....	56	790231.....	65	793611.....	26			CSU795638.....	37	
784085.....	56	790984.....	22	793612.....	26			CSU795639.....	37	
784086.....	56	790985.....	22	793613.....	26			CSU795640.....	37	
784087.....	56	790986.....	22	793614.....	26			CSU795641.....	37	
784088.....	56	790987.....	22	793615.....	46			CSU795653.....	37	
784089.....	25	790988.....	22	793616.....	46			CSU795654.....	37	
784090.....	25	790989.....	22	793617.....	46			CSU795660.....	37	
784091.....	25	790990.....	22	793618.....	46			CSU795661.....	37	
784092.....	25	791205.....	30	793619.....	46			CSU795662.....	37	
784093.....	25	791207.....	50	793620.....	46			CSU795663.....	37	
784094.....	25	791273.....	55	793621.....	46			CSU795664.....	37	
784095.....	25	791274.....	55	793622.....	46			CSU795700.....	37	
784096.....	25	791275.....	55	793669.....	67			CSU795867.....	58	
784096.....	25	791276.....	55	793670.....	67			CSU795868.....	27	
784097.....	57	791277.....	55	793671.....	67			CSU795869.....	58	
784098.....	57	791278.....	55	793672.....	67			CSU795871.....	58	
784099.....	57	791279.....	55	793673.....	67					
784100.....	57	791280.....	55							

